

TO-30000 UAZ HUNTER

Repair instructions number
00503

Repair instructions name
TO-30000 UAZ Hunter

Applies to
2924000001200
...

Model
HUNTER

Production period
2019

Modification
Not selected

Special tools

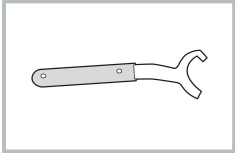

Wrench for holding the water pump shaft
005500000404900

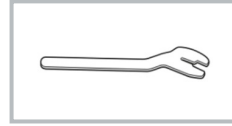

Fan viscous clutch removal key
005500000355600

General equipment

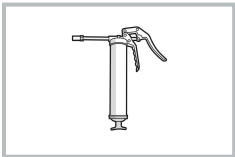

Grease gun

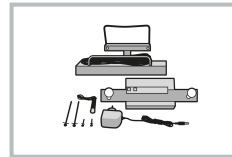

A device for measuring the total backlash of the steering

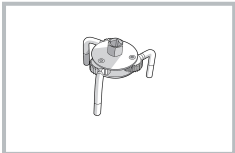

Oil filter remover



Tire pressure gauge

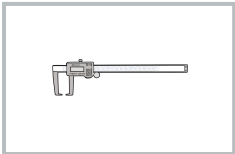

Caliper

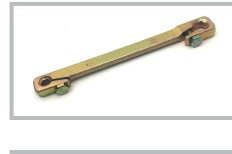

Brake pipe wrench

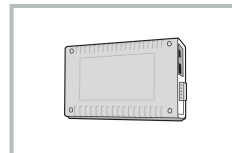

Diagnostic system UAZ

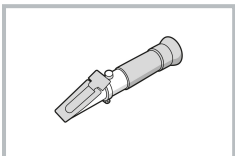

A device for measuring the density of a coolant (refractometer)

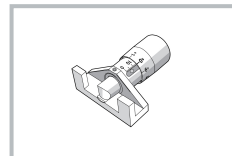

Universal belt tension tester

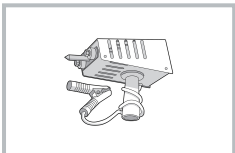

Load fork

Refer to the instructions - HUNTER - Car installation on lift (X) (00410)

1. Work outside the car:

IMAGE

OPERATION DESCRIPTION



1. Check by inspection for chips, cracks and foci of corrosion of the body paintwork.

The presence of chips, cracks and centers of corrosion of the body paintwork is not allowed.

Img 1



2. Check by inspection for chips, cracks on glass and rear-view mirrors, lighting devices and light alarms.

The presence of chips, cracks on glass and rear-view mirrors, lighting and light signaling devices is not allowed.



Img 2

3. Apply grease to the door hinges.

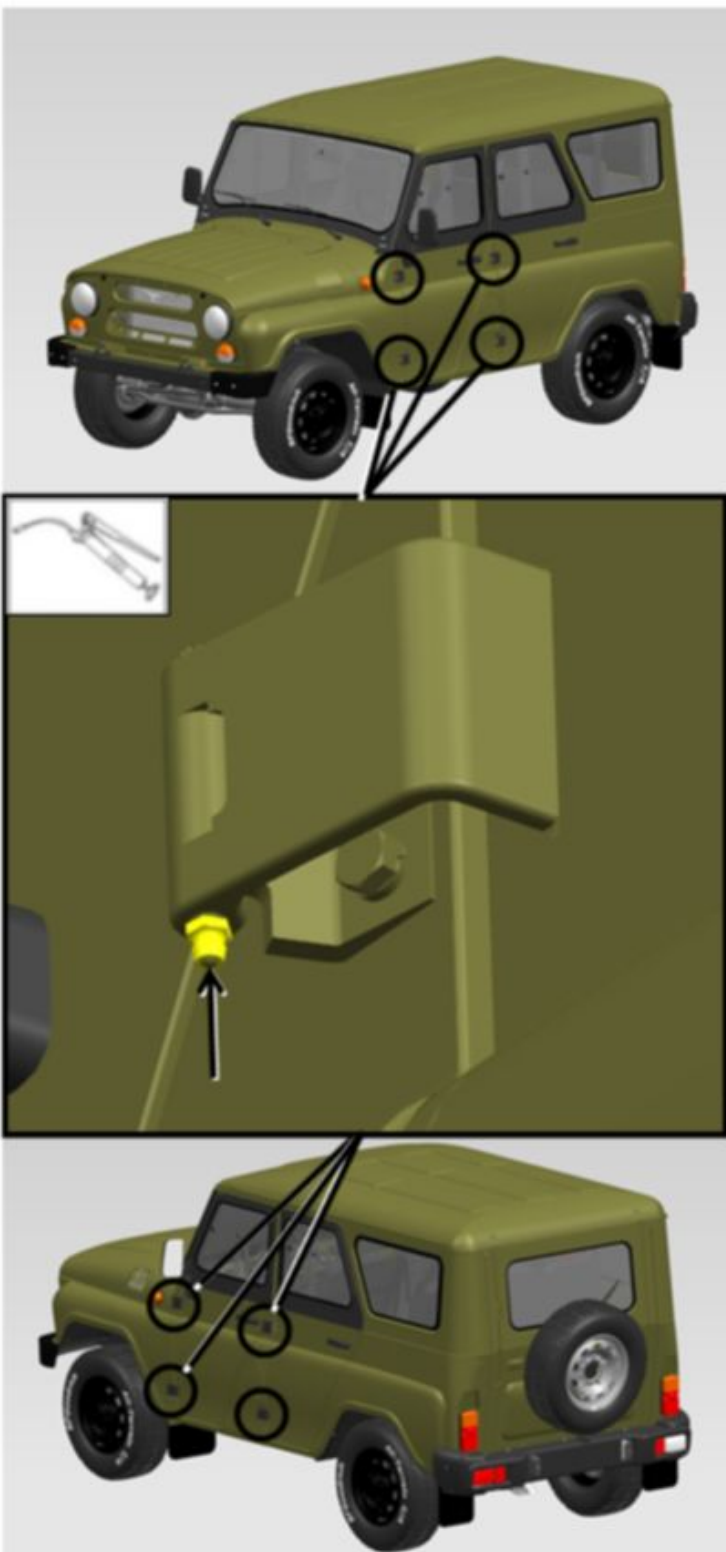

Img 3

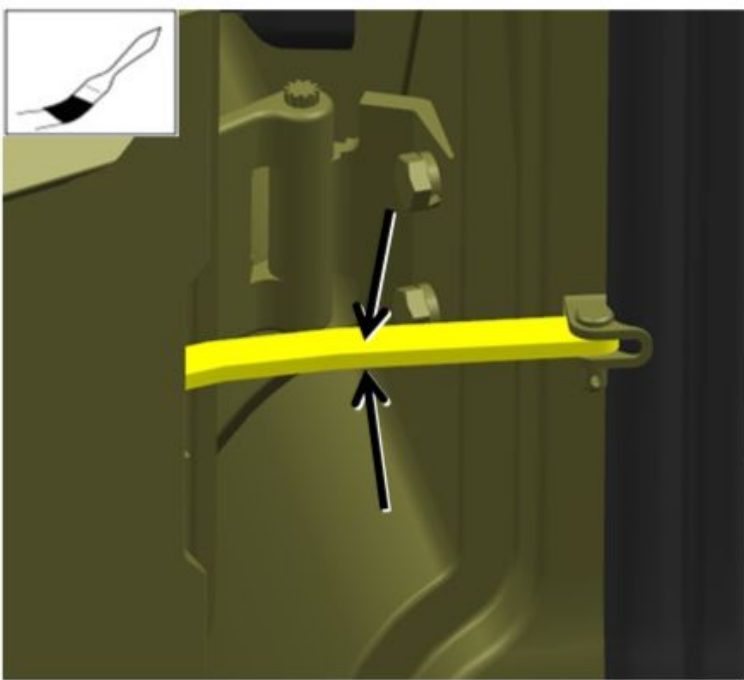

4. Apply grease to the door stops.

Img 4

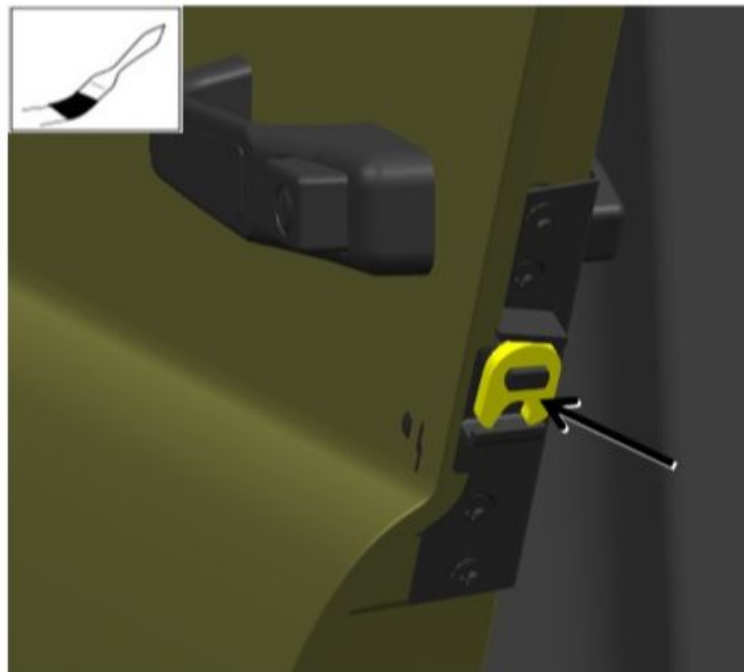

5. Apply grease to the door locks.

Img 5

6. Apply grease to the hood lock and hook.

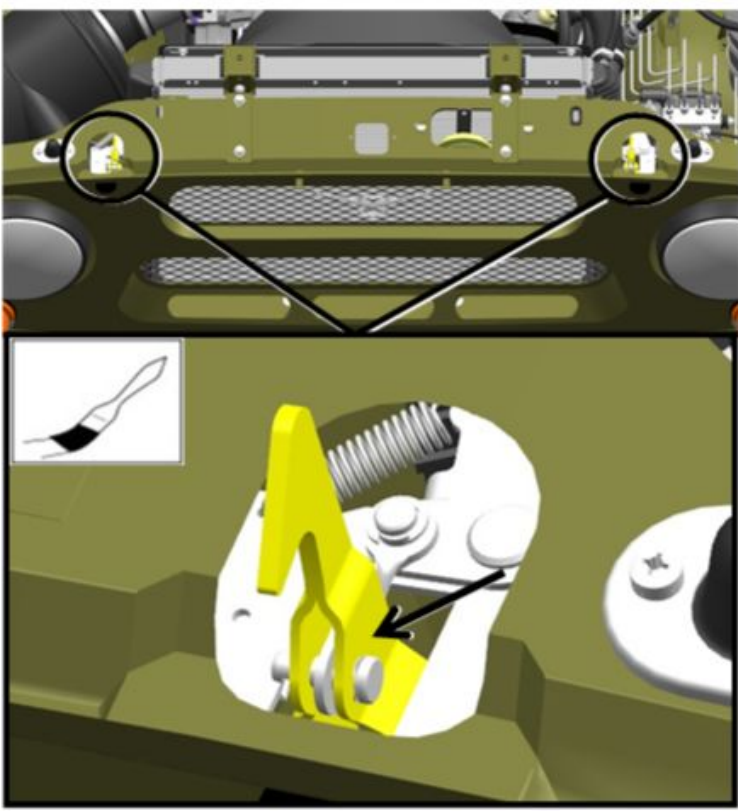

Img 6

2. Work inside the car:

IMAGE

OPERATION DESCRIPTION



1. Install the parts of the device for measuring the total backlash of the steering on the steering wheel and on the left front wheel of the car.

2. Check the total backlash of the steering according to the operating instructions of the device.

The total backlash should not exceed 20 degrees.



Img 1

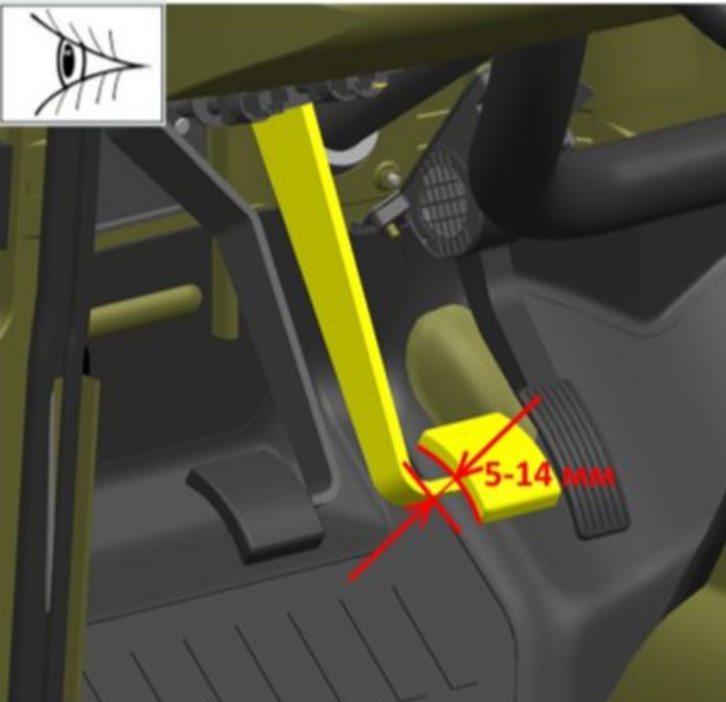

Img 2

3. Check the free play of the brake pedal.

The amount of free travel of the brake pedal should be 5-14 mm.

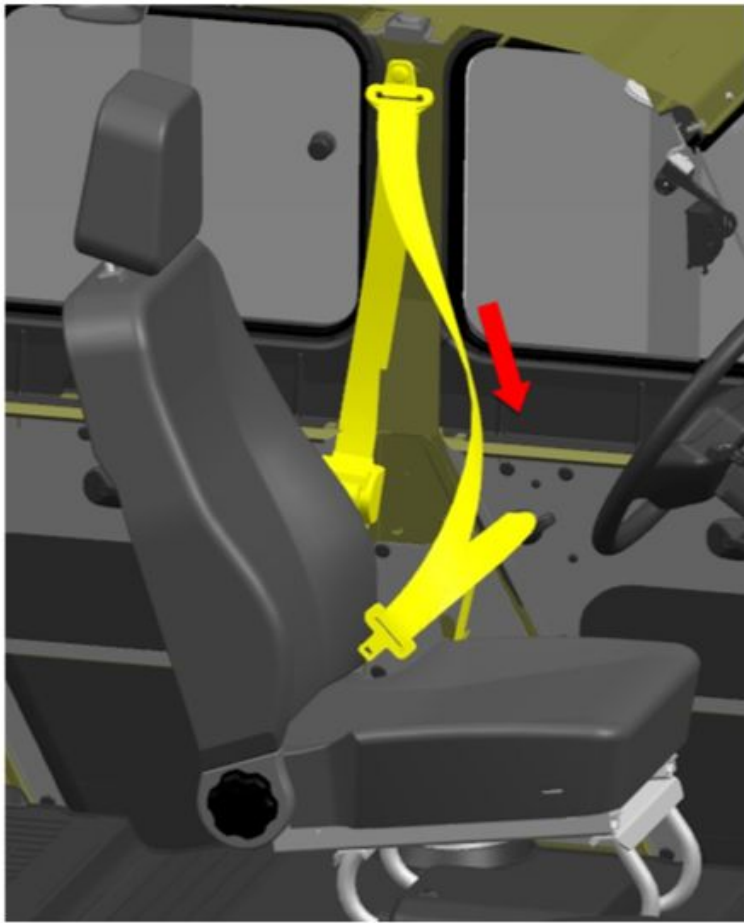

Img 3

4. Check the operation of the driver's belt retractor.

The device should wind the belt around the reel easily and without jamming.

5. Check the functionality of the inertia reel of seat belts.

When pulling sharply at different lengths, the inertial coil should block the change in the length of the belt.

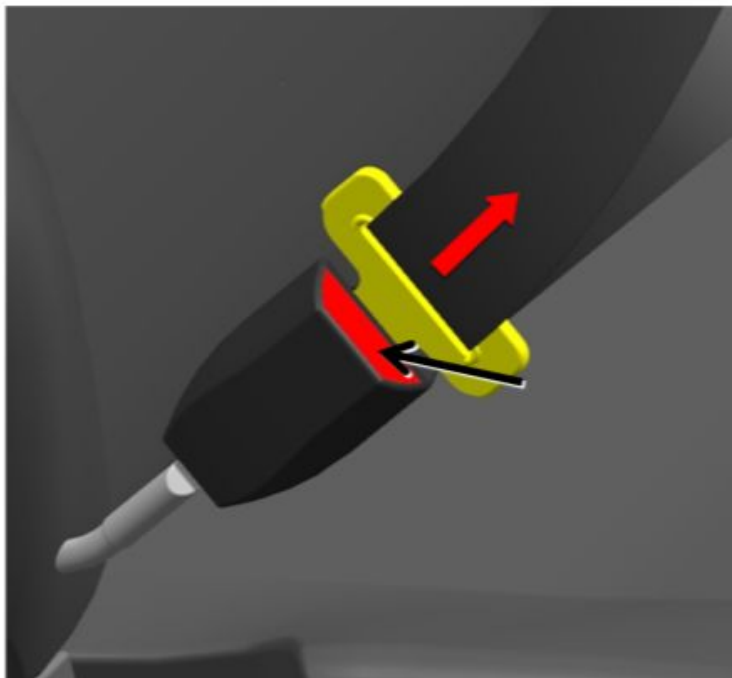

Img 4

6. Check the operation of the driver's belt locking device.

The belt buckle must fit securely in the device. When unlocking, the buckle must be thrown out of the locking device.

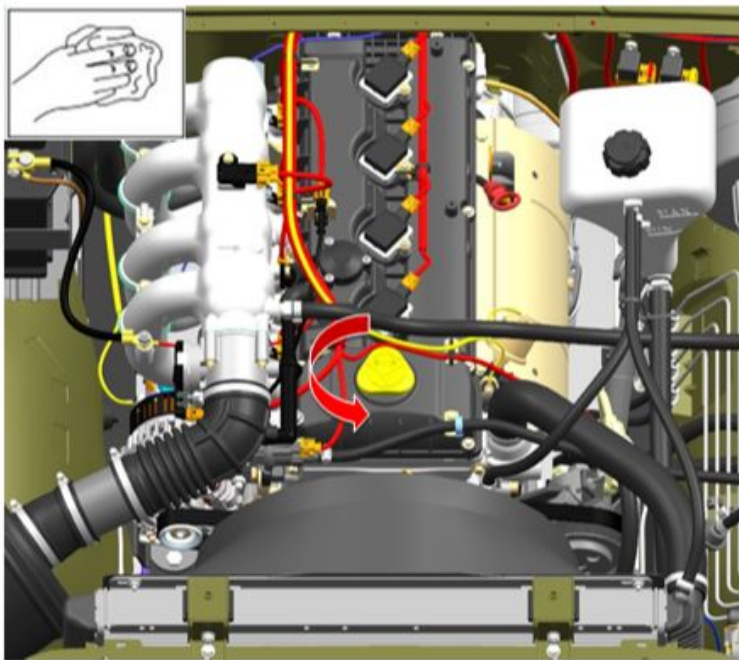

Img 5

7. Remove the engine oil filler cap.

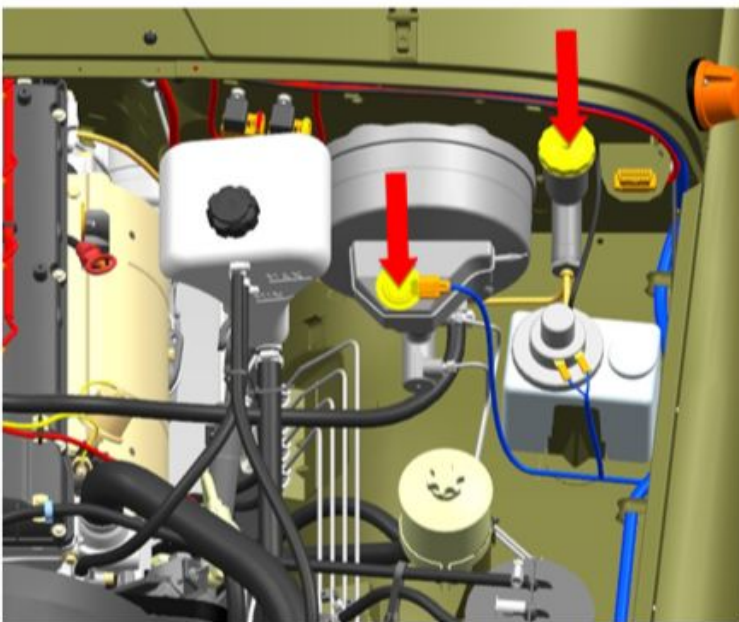

Img 6

8. Remove the covers from the master cylinder and clutch cylinder reservoirs.

9. Install the device for bleeding the brake system and clutch system on the reservoirs.

3. Work under the car bottom:

IMAGE

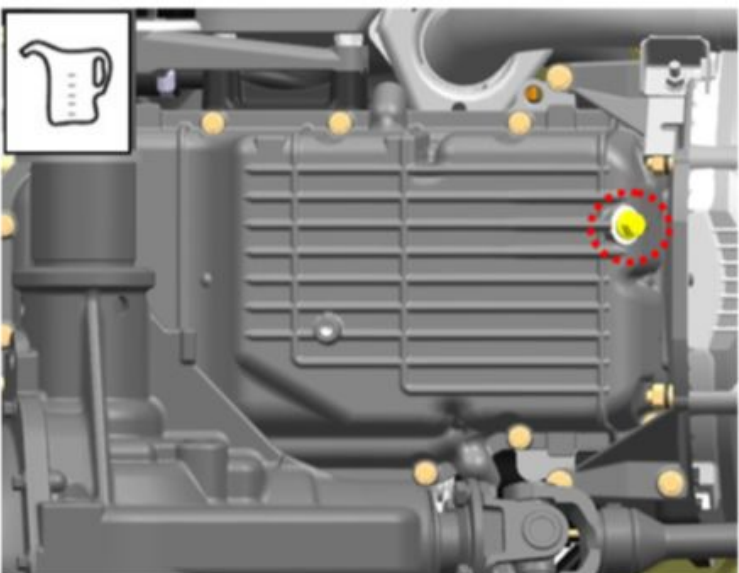

Img 1

OPERATION DESCRIPTION

1. Place a container under the oil sump to drain the oil.

2. Unscrew the drain plug on the engine crankcase.

tightening torque- 28 N·m

⚠ NOTIFICATION: Reuse of the drain plug O-ring is not permitted.

3. Let the oil drain.

Waiting time is 3-5 minutes.

4. Close the drain plug.

tightening torque- 28 N·m

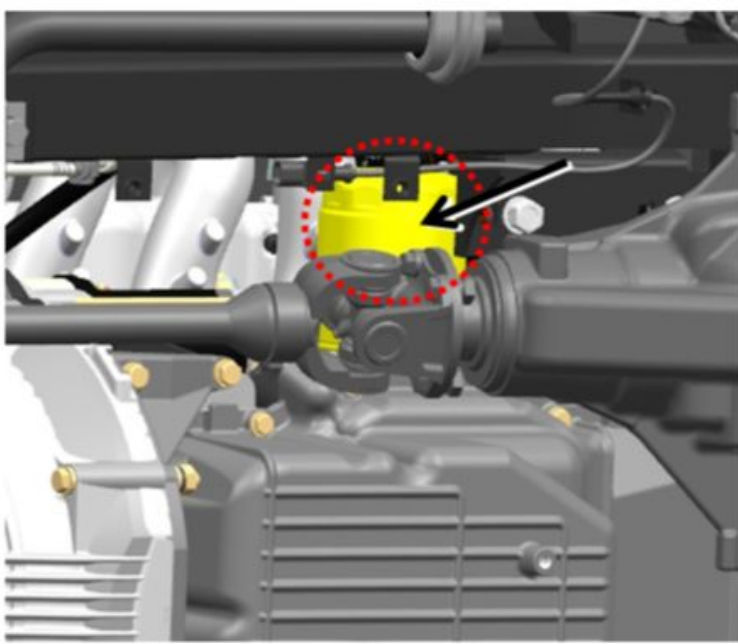

Img 2

5. Unscrew the oil filter.
tightening torque- 20 N·m

Make sure the filter O-ring is not left on the heat exchanger.

⚠ NOTIFICATION: Filter reuse is not allowed.

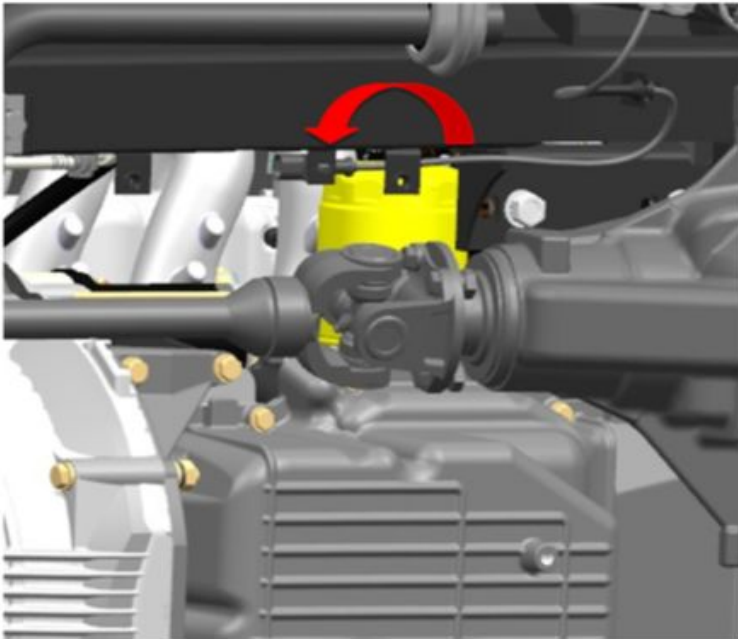

Img 3

6. Screw on the filter.

Screw in the filter until the O-ring touches the plane on the heat exchanger, and then turn the filter 3/4 turn.

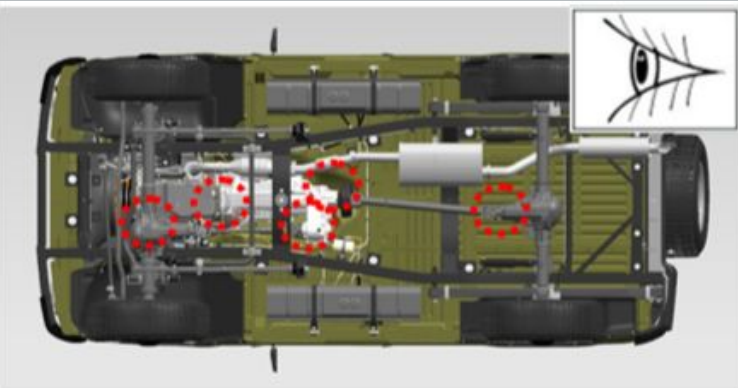

Img 4

7. Visually inspect the gaskets and oil seals of the engine, gearbox, transfer case, steering mechanism, front and rear axles.

Oil leakage and ejection are not allowed.



8. Inspect the engine mounts, brackets installed on the engine.
No delamination or rupture of engine mount cushions is allowed.

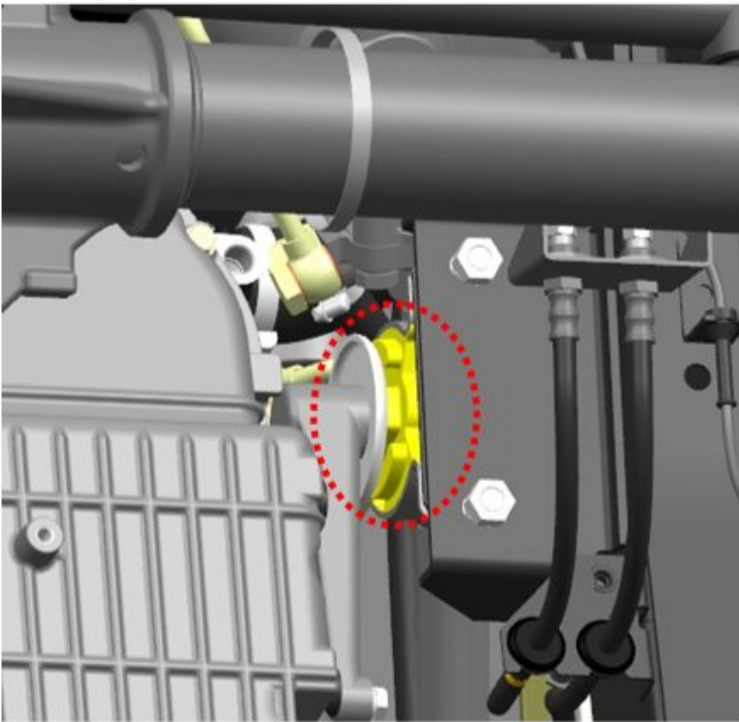
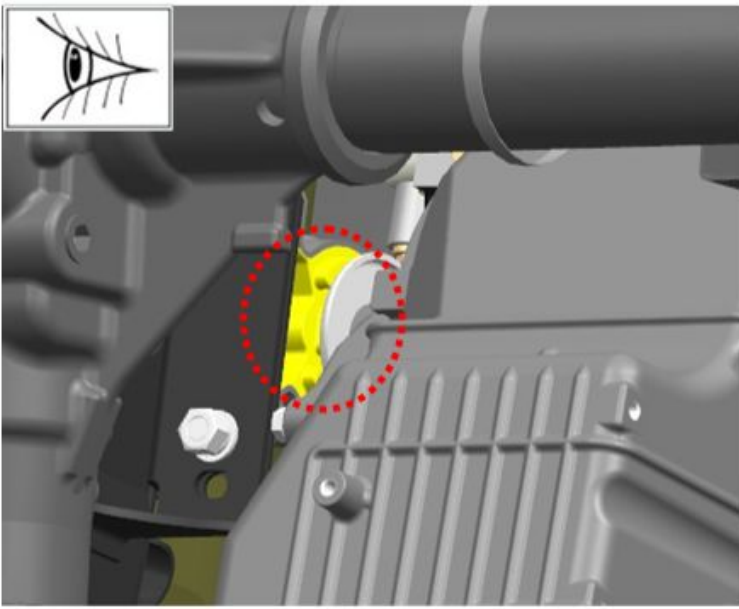

Img 5

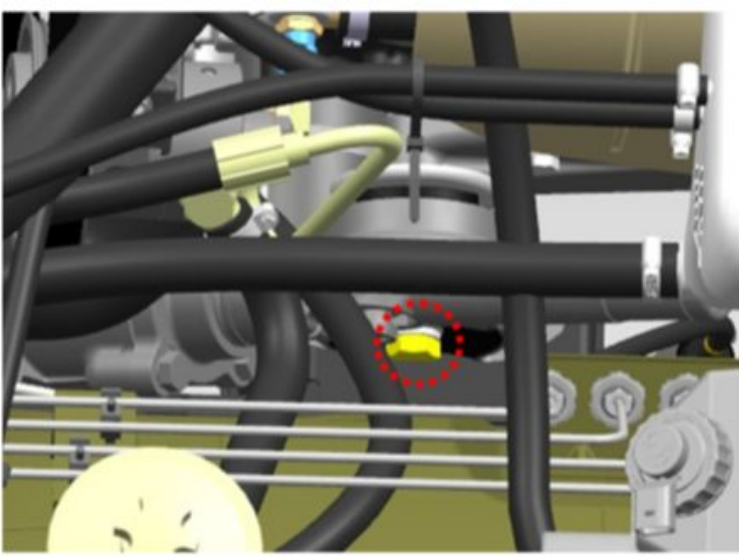

9. Tighten the bolts securing the front engine mounts to the brackets.

S=22

tightening torque- 100 N·m

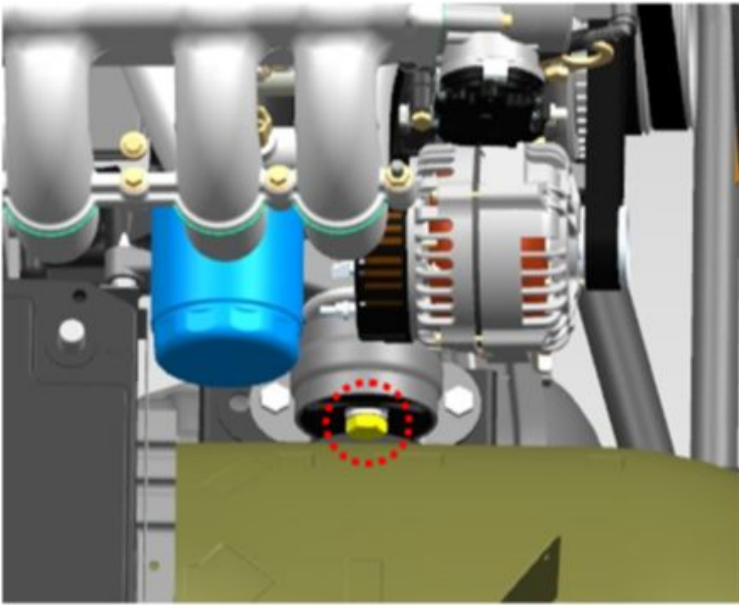

Img 6

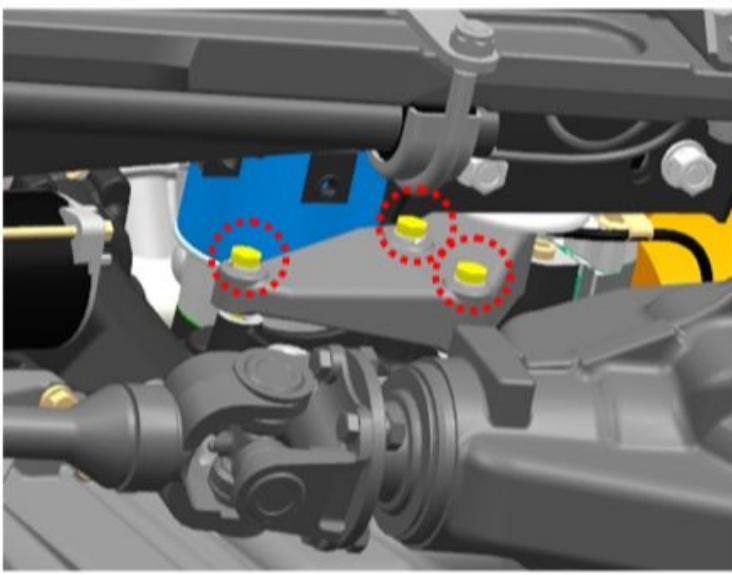

10. Tighten the bolts securing the brackets of the front engine mounts to the cylinder block.

S=14

tightening torque- 32 N·m

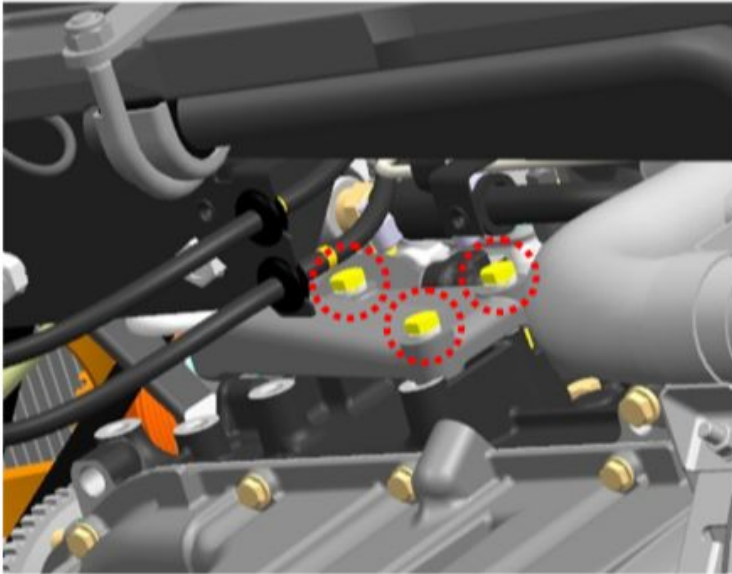

Img 7

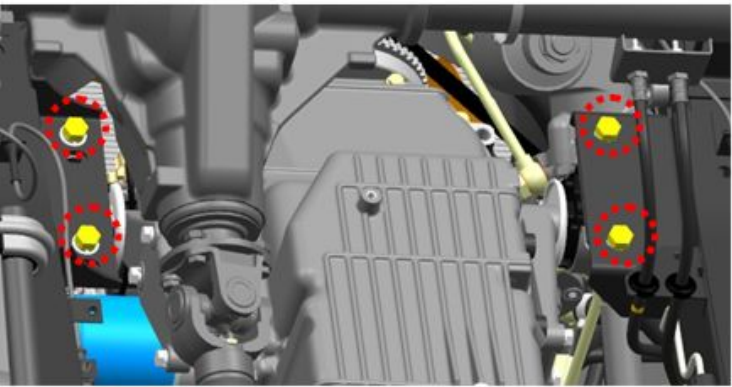

Img 8

11. Tighten the nuts securing the front engine mounts to the frame brackets.

S=17

S=19

tightening torque- 56 N·m

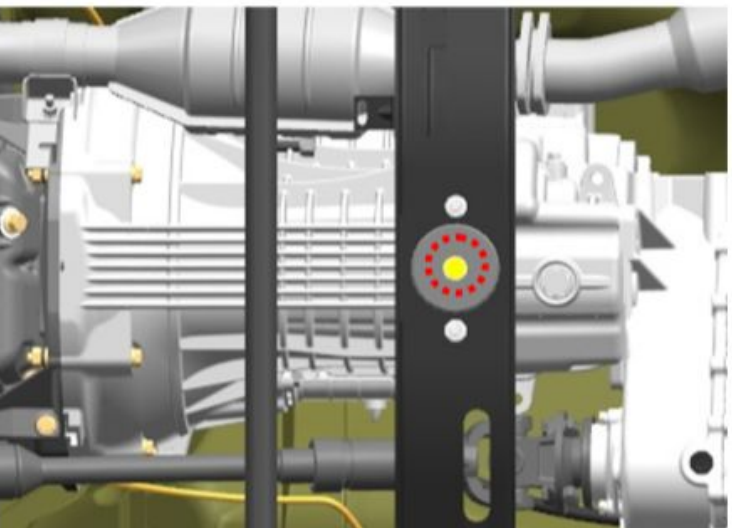

Img 9

12. Tighten the bolt securing the rear engine mount to the bracket.

S=19

tightening torque- 80 N·m

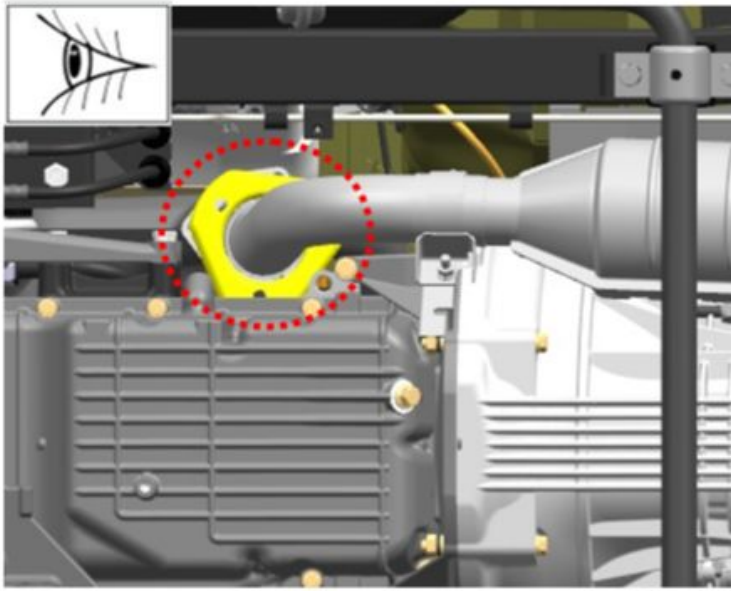

13. Visually check the connections of the exhaust system for leaks.

Leakage of connections is not allowed.

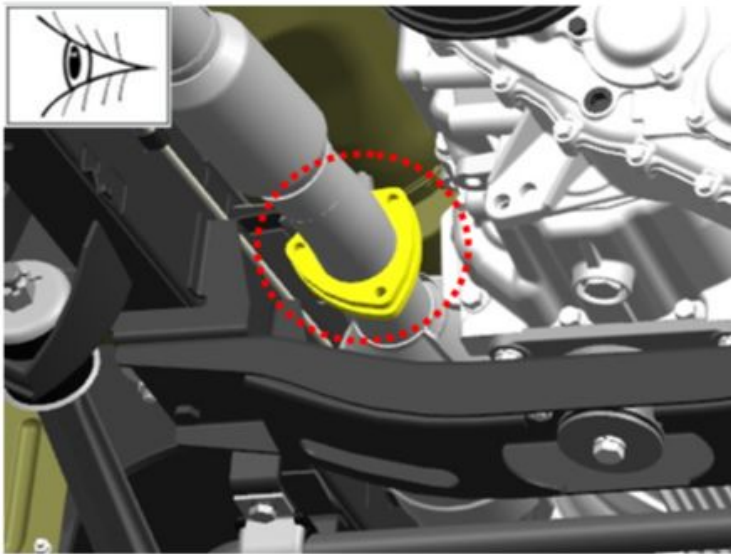

Img 10

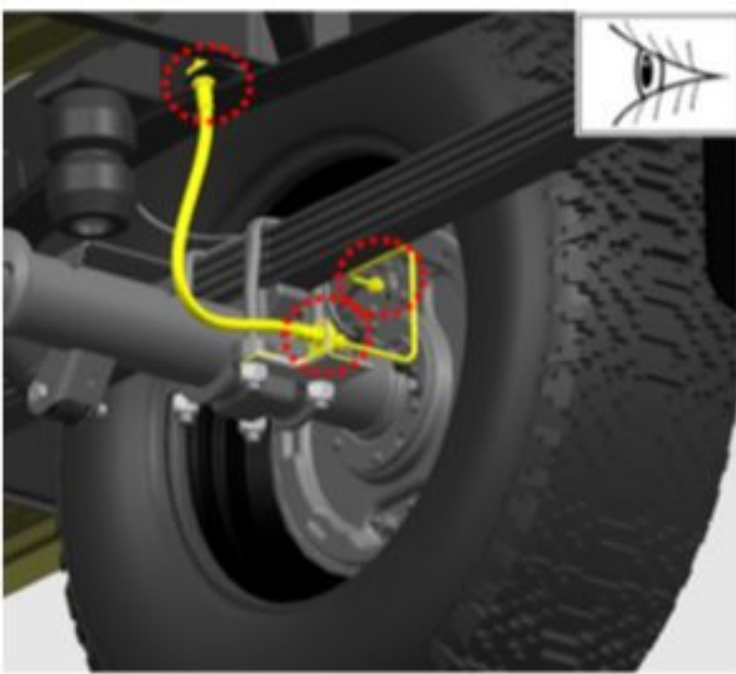

14. Visually check the connections of pipelines of cooling systems, heating, power supply, hydraulic drive of brakes and clutch, vacuum take-off system from the vacuum brake booster, condition of pipes and hoses.

Leakage of coolant, fuel, brake fluid, leaks in the vacuum hose (vacuum booster) are not allowed. Operation of deformed pipes of the hydraulic drive of brakes, parts of the vacuum take-off system is not allowed.

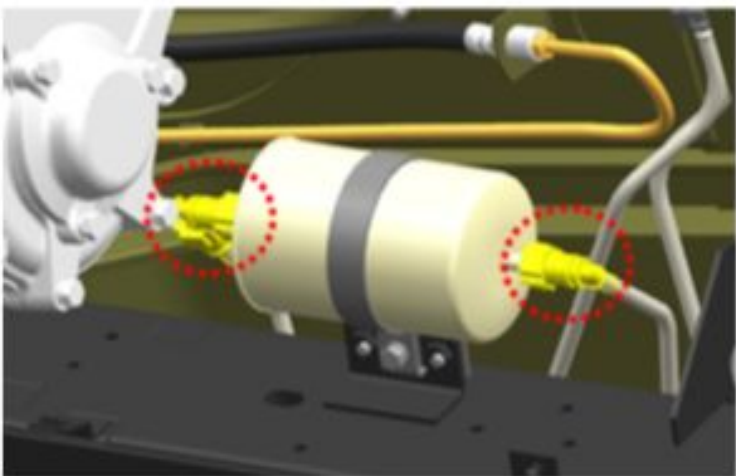
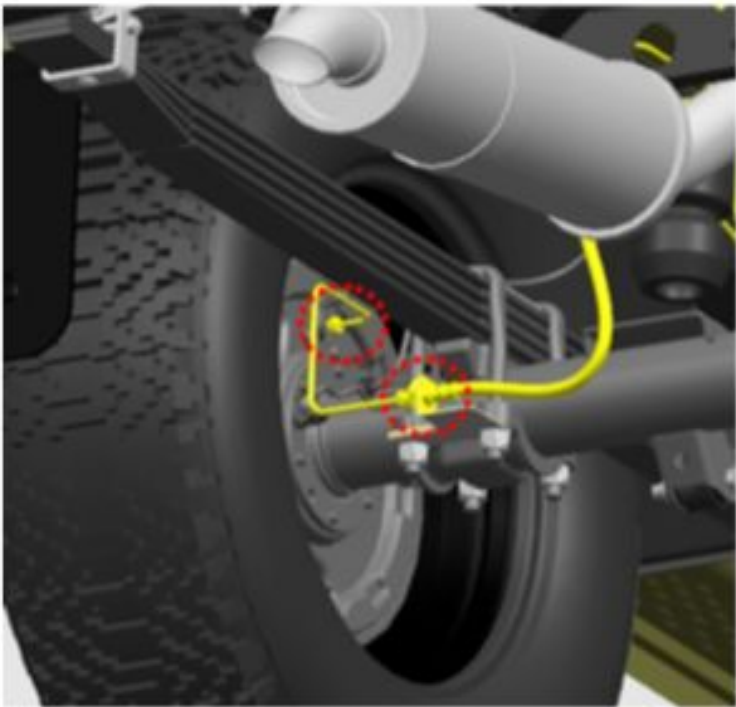

Img 11

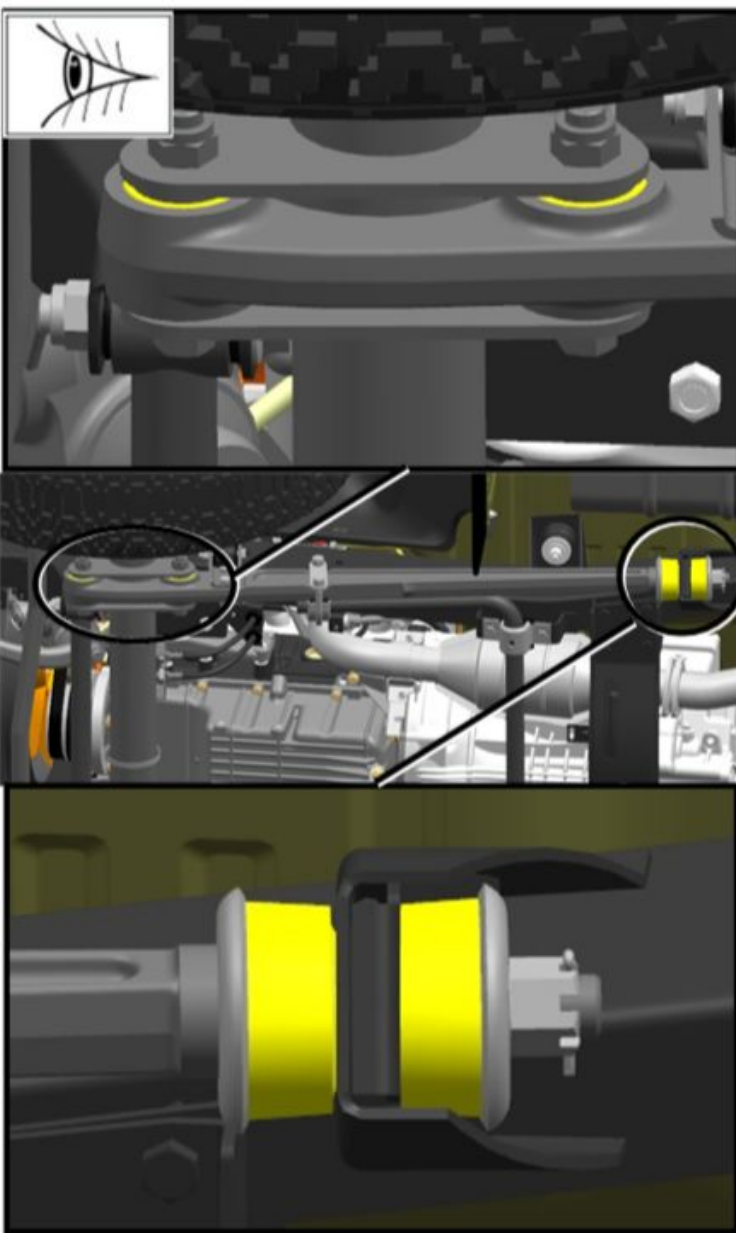

Img 12

15. Inspect the longitudinal rod joints.

The hinges should not have cracks, breaks, undercutting and wear of rubber along the outer end of the hinge.

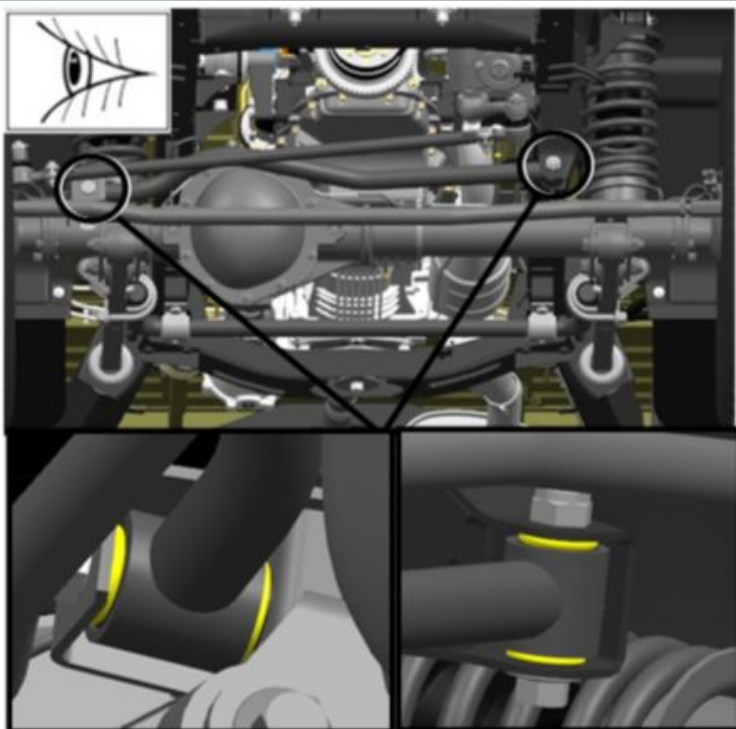

Img 13

16. Inspect the transverse link joints.

The hinges should not have cracks, breaks, undercutting and wear of rubber along the outer end of the hinge.

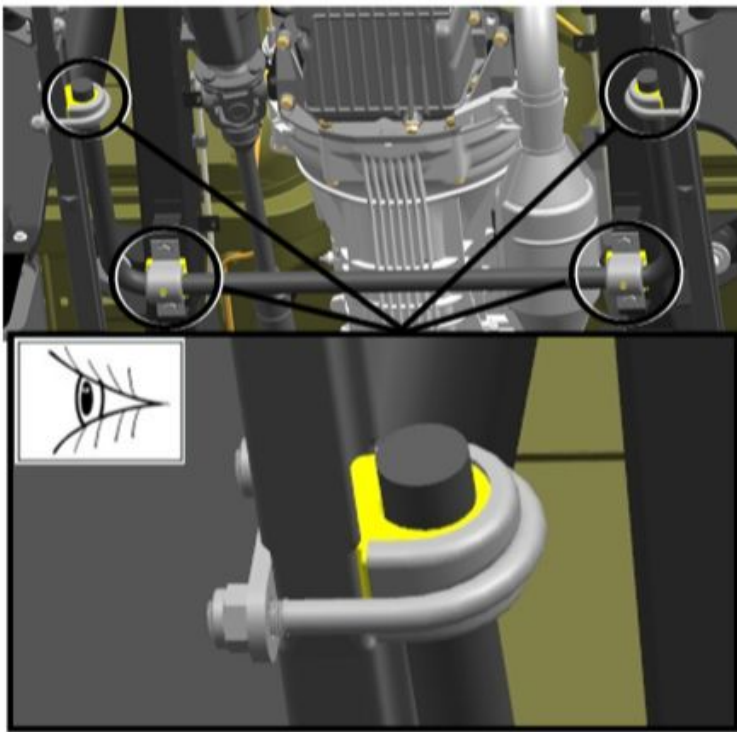

17. Inspect the front anti-roll bar joints.

The hinges should not have cracks, breaks, undercutting and wear of rubber along the outer end of the hinge.

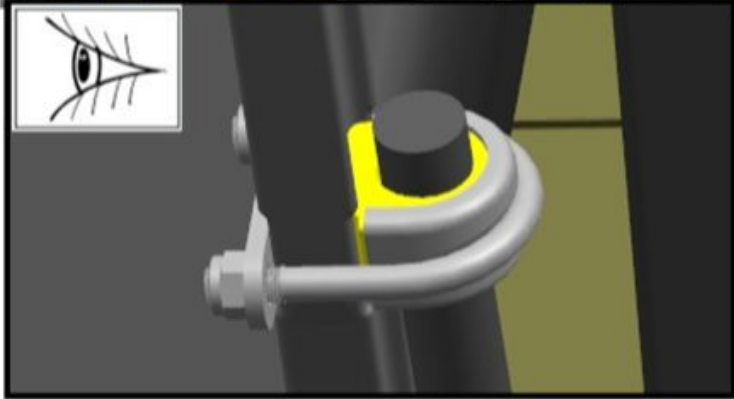

Img 14

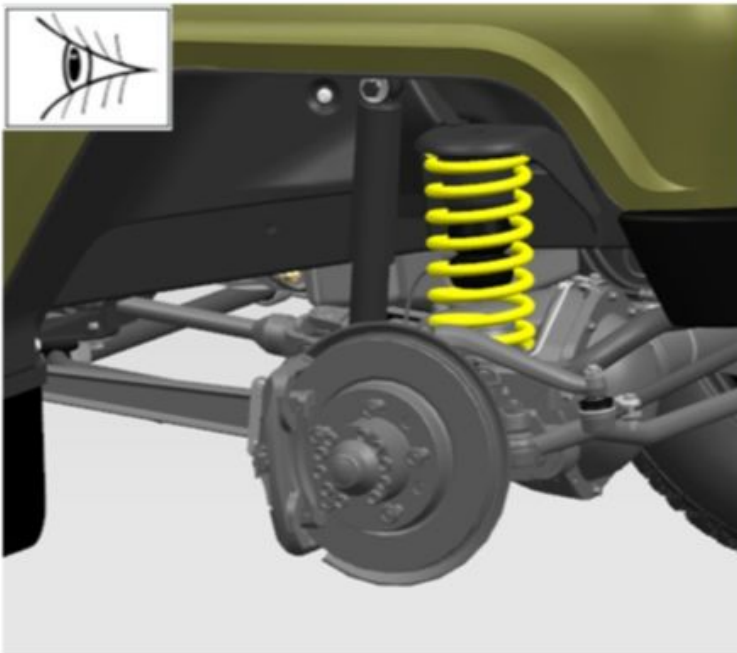

18. Inspect the springs.

The springs should not have mechanical damage and deformation of the coils.

Img 15

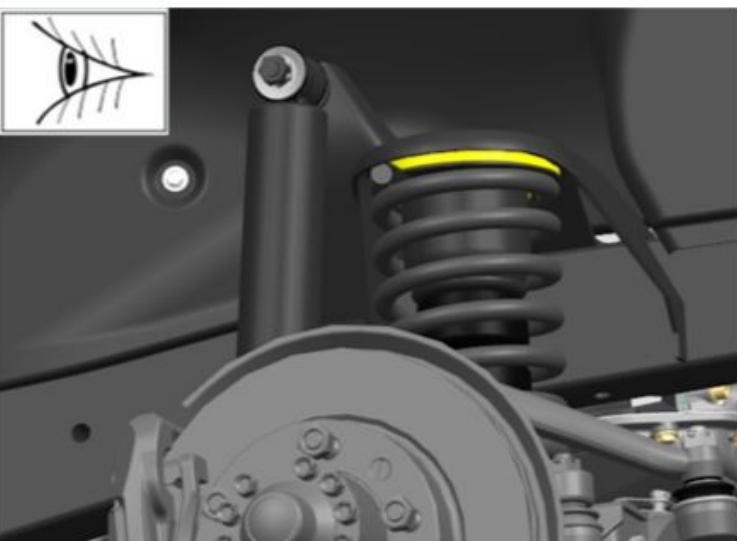

19. Inspect the rubber spring seating pads.

The gaskets should not have mechanical damage and deformation.

Img 16

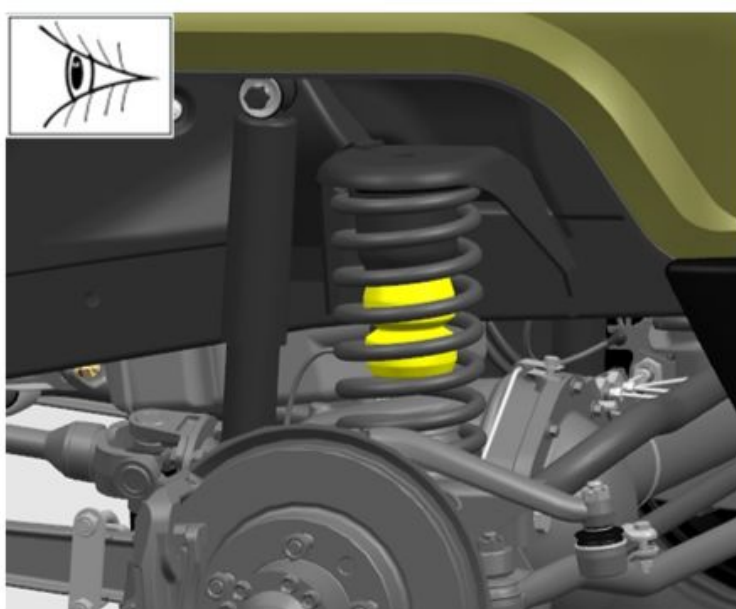

20. Inspect the spring buffers.

Spring buffers should be free from cracks, breaks and deformations.

Img 17

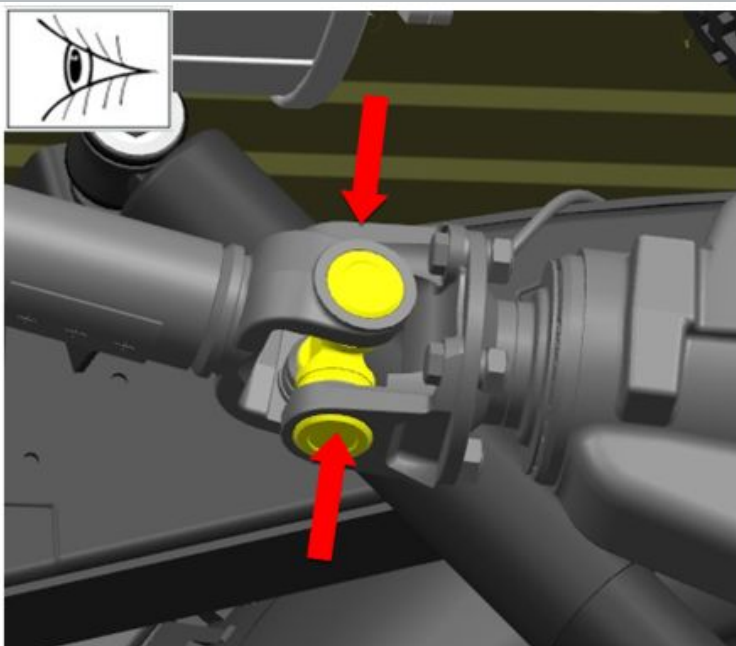

21. Check the backlash in the crosspieces of the cardan shafts by applying an alternating hand force along the axes of the crosspieces.

Backlash in the crosspieces is not allowed.

22. Rotate the crosspiece 90 degrees and recheck.

Backlash in the crosspieces is not allowed.

Img 18

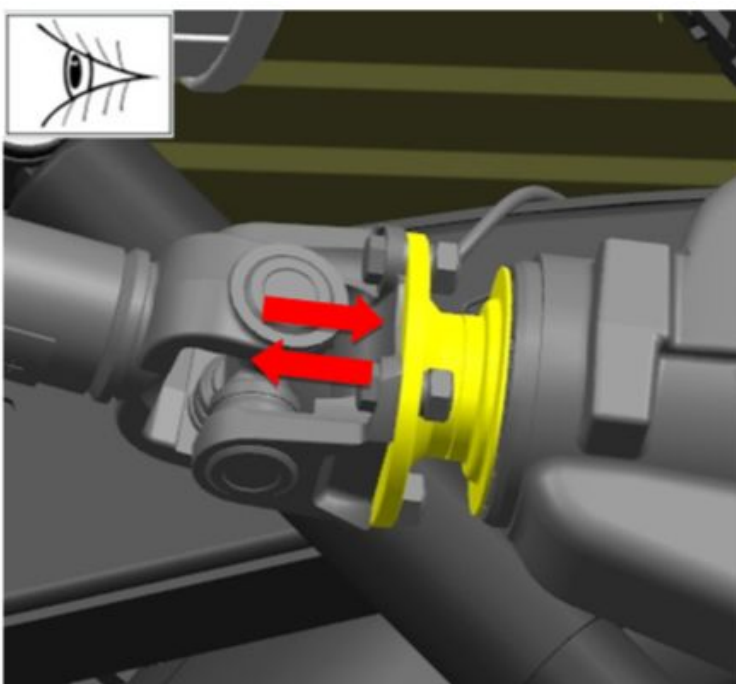

23. Check the presence of axial play in the bearings by moving the drive gear for the propeller shaft flange.

Img 19



24. Check the play in the wheel hub bearings by swinging the wheels in a vertical plane.

No play in the hub bearings is allowed.

Img 20



25. Check the smoothness of the wheel rotation.

Rolling of the hub bearings and wheel wedging during rotation is not allowed.

Img 21



26. Inspect the tires of the wheels.

27. Inspect the wheel rims.

28. Check the value of the pressure in the tires of the wheels.

Tire pressures must comply with the values in Table 1.

Img 22

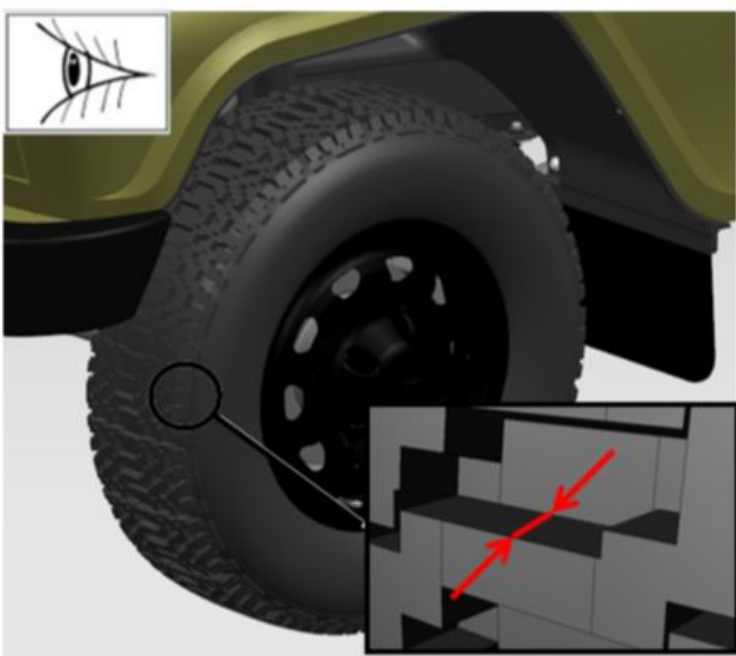

Img 23

29. Measure the residual depth of the tread pattern.
The residual tread depth must be more than 1.6 mm.

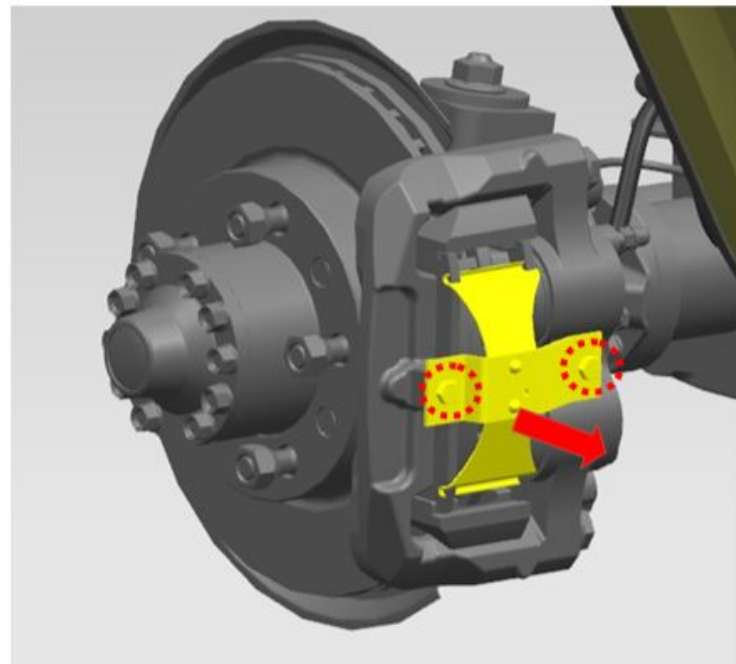

Img 24

30. Remove the pads compression spring securing bolts.
S=12
tightening torque- 25 N·m

31. Remove the pad compression spring.

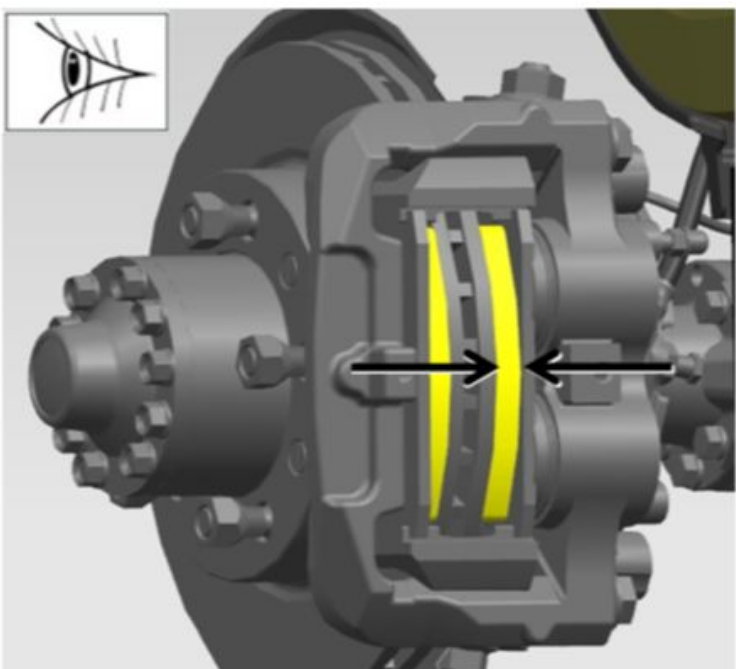

Img 25

32. Inspect the pads through the window in the caliper.

33. Measure the thickness of the friction layer of the pads.

The maximum permissible minimum thickness of the friction layer of the pads is 1.5 mm.

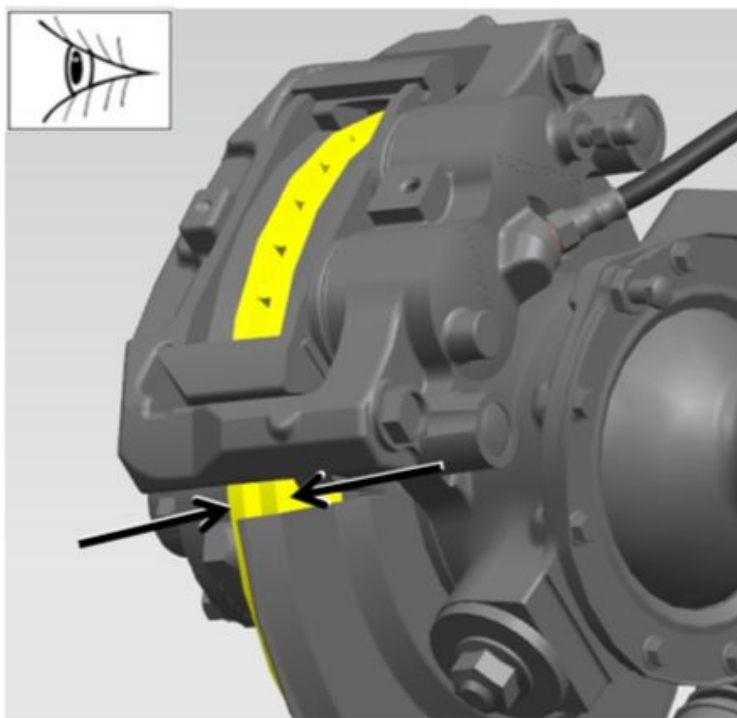

34. Inspect the front wheel brake discs.

35. Measure the thickness of the brake disc.

The maximum permissible minimum thickness of the brake disc is 20.4 mm. Measure the thickness of the disc, stepping back from the edge of the disc by 10-15 mm.

Img 26



36. Remove the inspection hole blanking plugs.

Img 27

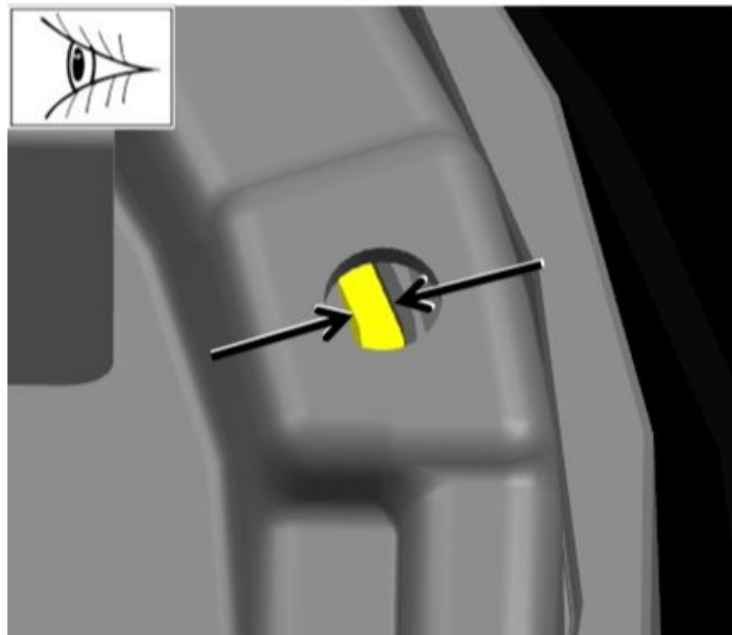

37. Inspect the rear wheel pads.

The maximum permissible minimum thickness of the friction layer of the pads is 1.0 mm.

Img 28

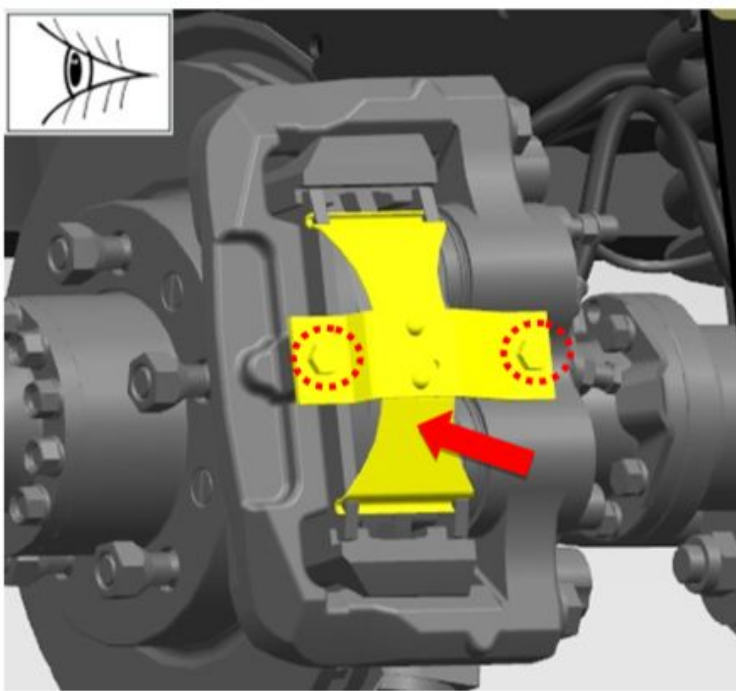

Img 29

38. Establish a spring of preloading of pads.
When installing, orient the spring as shown in the figure.

39. Tighten the spring retaining bolts.

tightening torque- 25 N·m

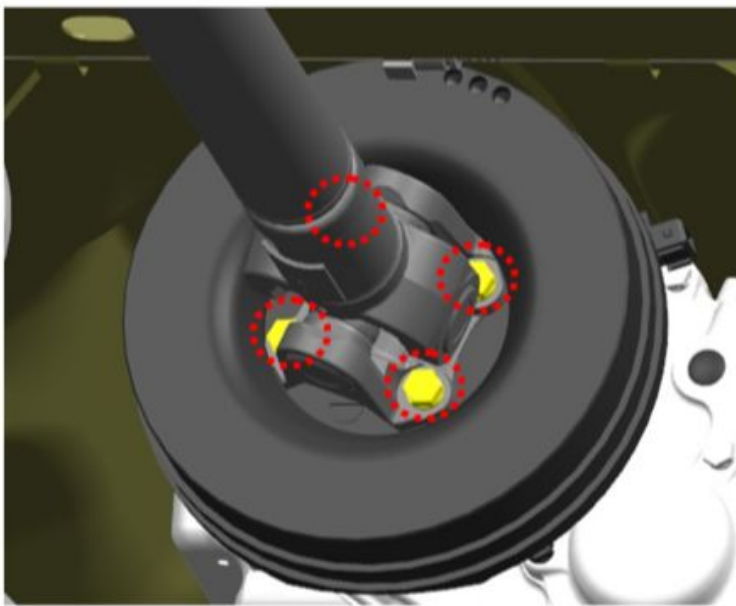

Img 30

40. Unscrew the boots for securing the rear propeller shaft.

S=14

tightening torque- 50 N·m

41. Remove the propeller shaft.

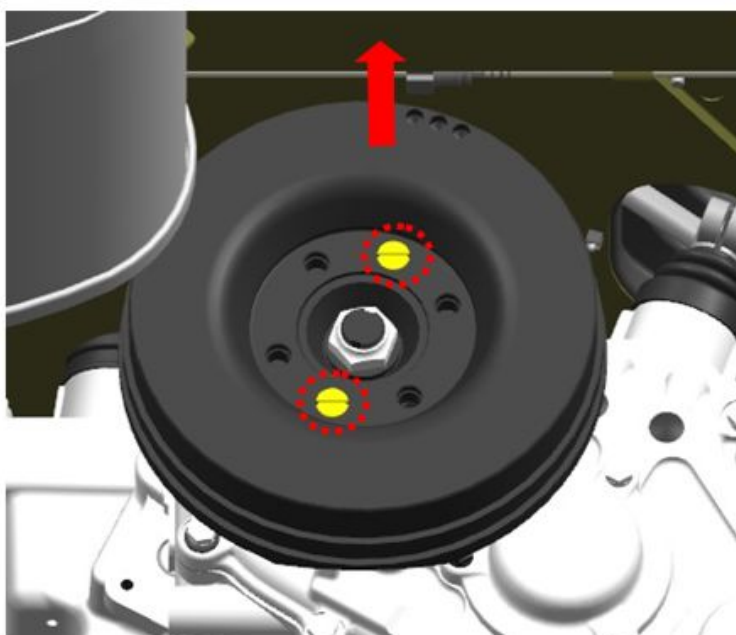

Img 31

42. Remove the parking brake drum fastening screws.

tightening torque- 7 N·m

43. Remove the drum.

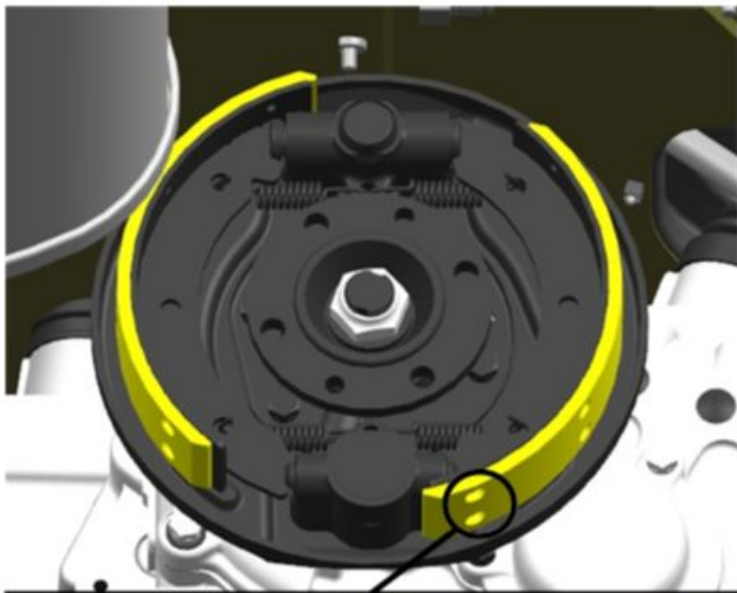

44. Inspect the parking brake linings.

When the pads are worn out (rivets sink less than 0.5 mm), the pads must be replaced.

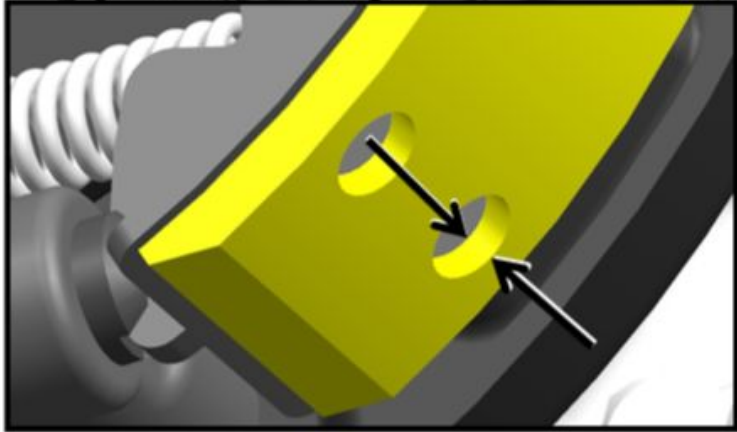

Img 32

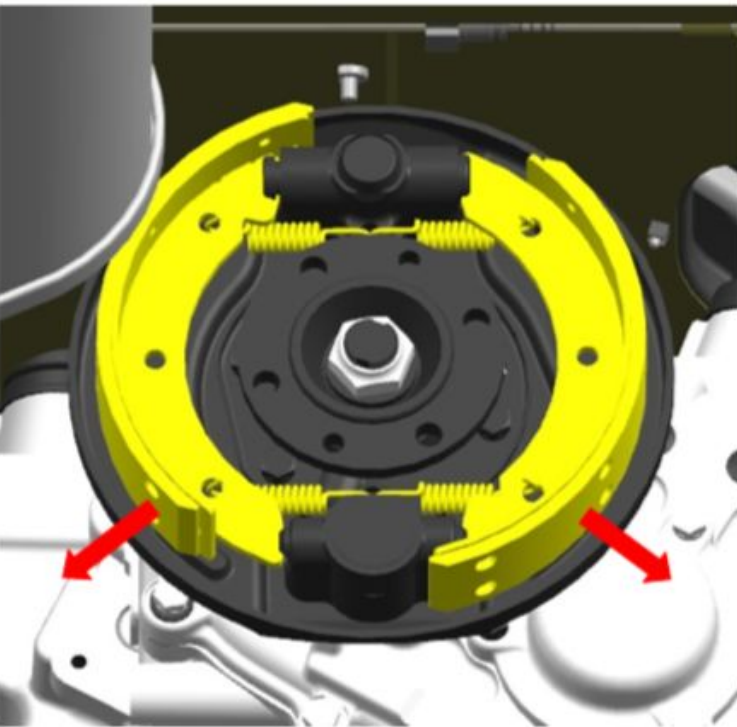

45. Remove the brake pads.

Img 33

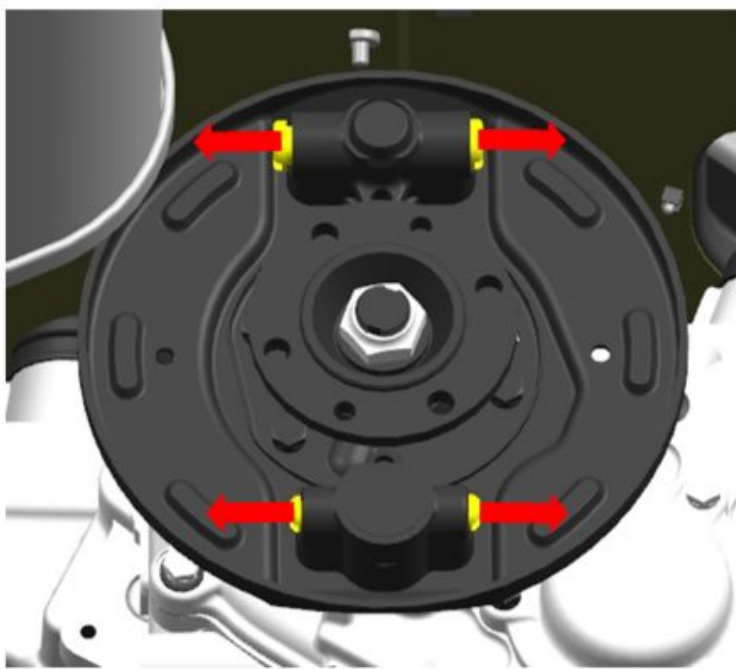

Img 34

46. Remove the fingers of the expanding and adjusting mechanisms of the parking brake.

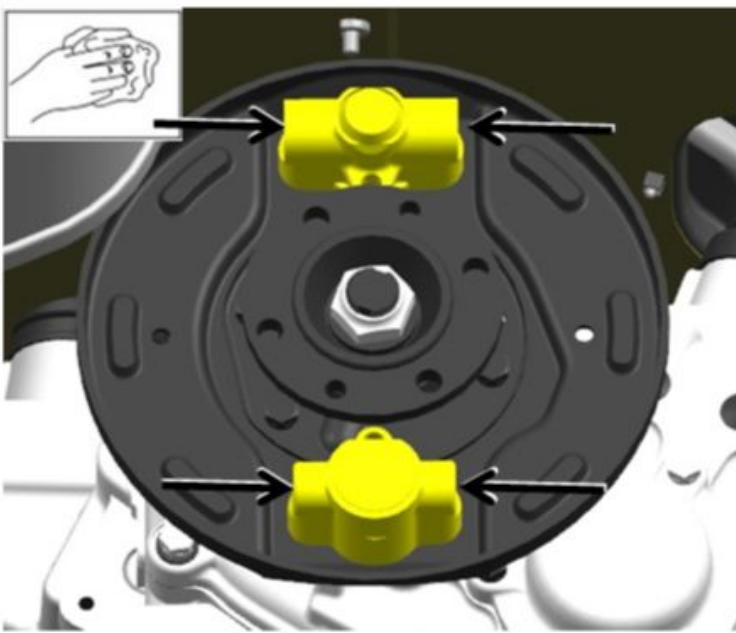

Img 35

47. Clean the expanding and adjusting mechanisms from dirt.

48. Put grease into the housing of the expanding and adjusting mechanisms.

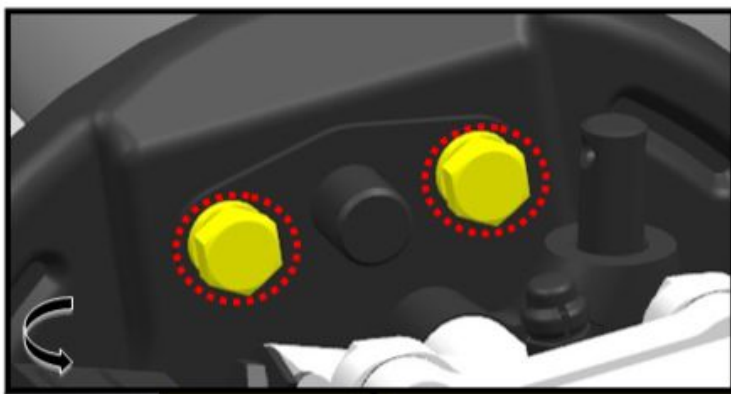

49. Tighten the fasteners of the adjusting and expanding mechanisms to the shield.

S=14

tightening torque- 35 N·m

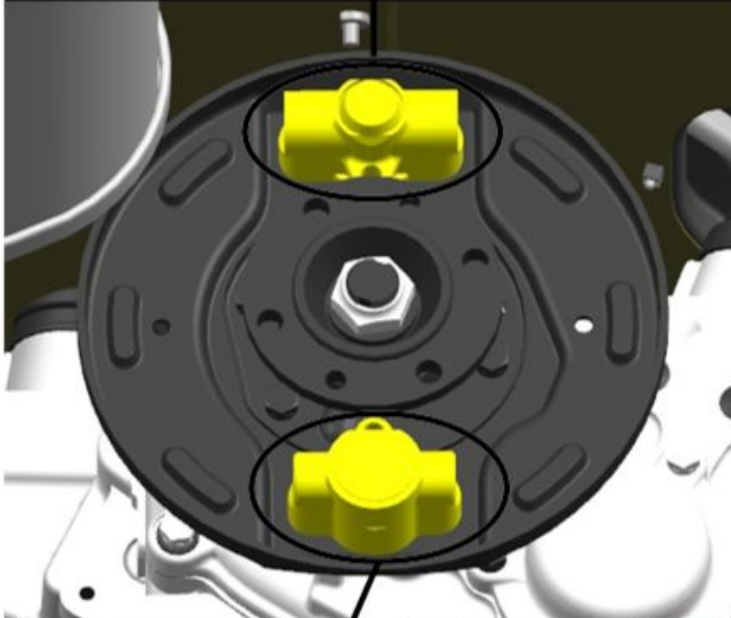

50. Assemble the parking brake.



Img 36

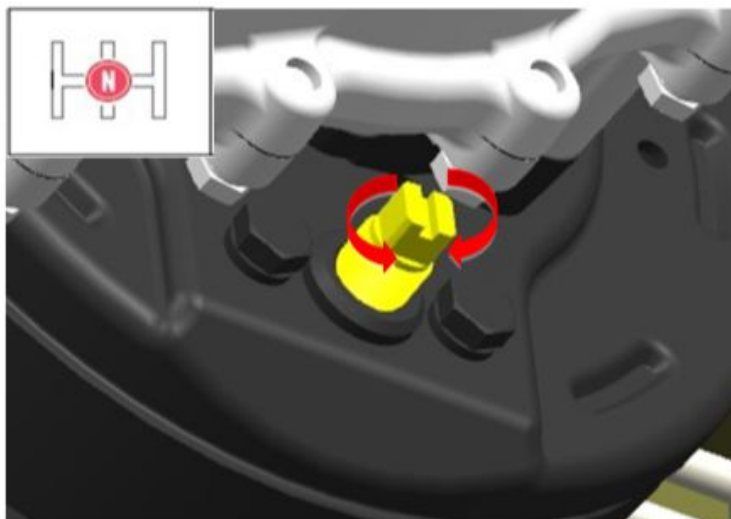

51. Adjust the parking brake pads.

Adjust the parking brake pads with the transfer case lever in neutral. Screw in the adjusting screw while rotating the parking brake drum until the drum stops turning. Loosen the adjusting screw 1/3 - 1/2 turn (4 - 6 clicks) until the drum rotates freely.

Img 37

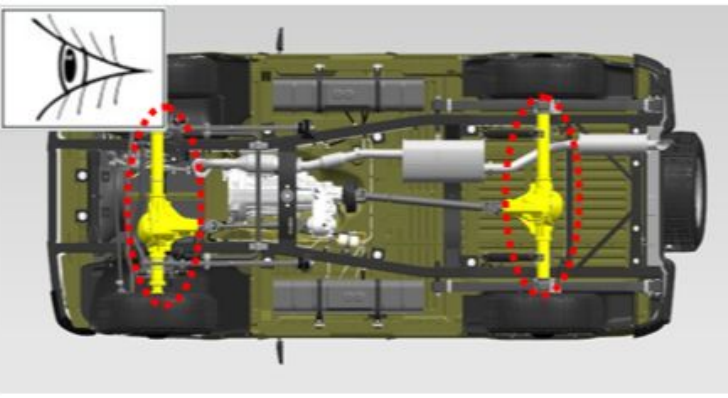

Img 38

52. Inspect the bridges.

Bridges should be free of visible damage, cracks and leaks.

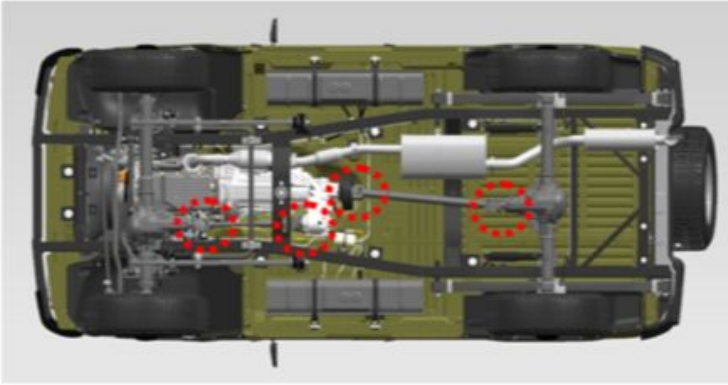

Img 39

53. Tighten the fasteners of the propeller shaft flanges.

S=17

S=14

tightening torque- 50 N·m

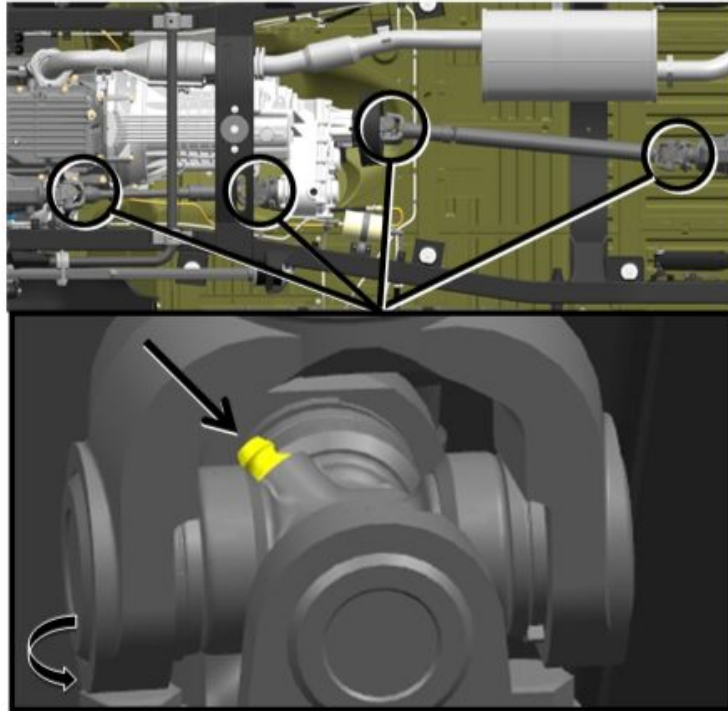

Img 40

54. Lubricate the joints of the front and rear propeller shafts.

Lubricate until it comes out from under the working edges of the crosspiece cuffs.

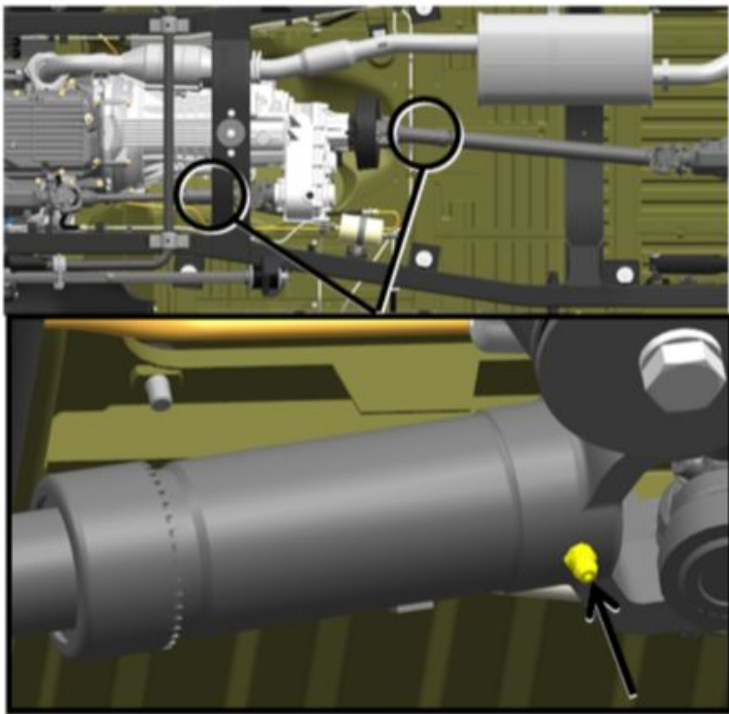

Img 41

55. Lubricate the splines of the front and rear propeller shafts.
Make 3-5 strokes without waiting for the lubricant to come out.

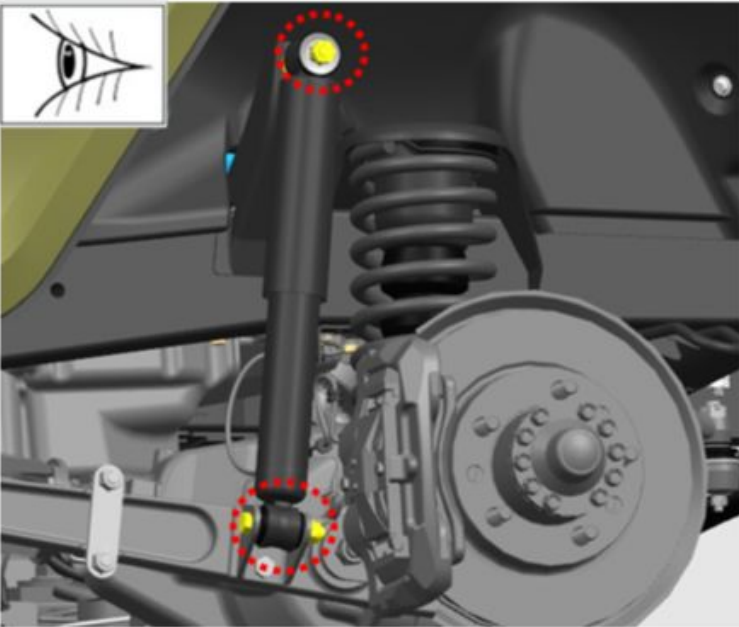

Img 42

56. Inspect the front suspension shock absorbers.
Oil fogging of the shock absorber does not indicate a malfunction and is acceptable. The appearance of drips on the shock absorber body, indicating a loss of tightness, is not allowed.

57. Tighten the front suspension shock absorbers.
tightening torque- 60 N·m

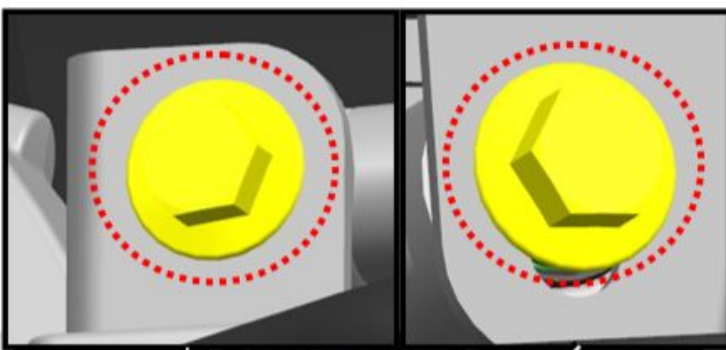

58. Tighten the nuts securing the longitudinal rods and lateral rods of the front suspension.

S=24

S=21

S=22

tightening torque- 150 N·m

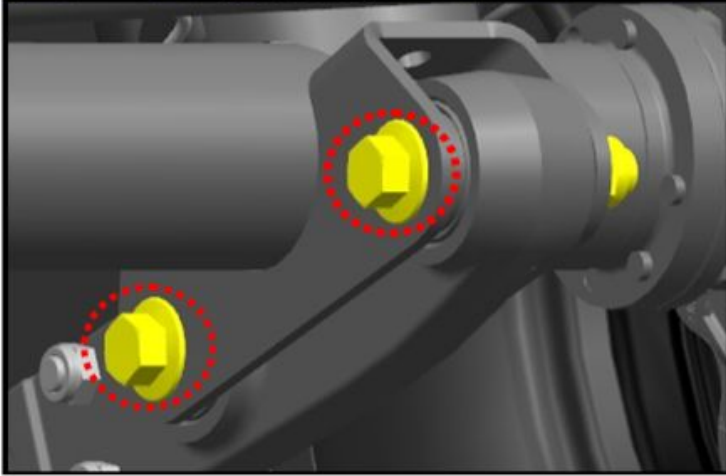
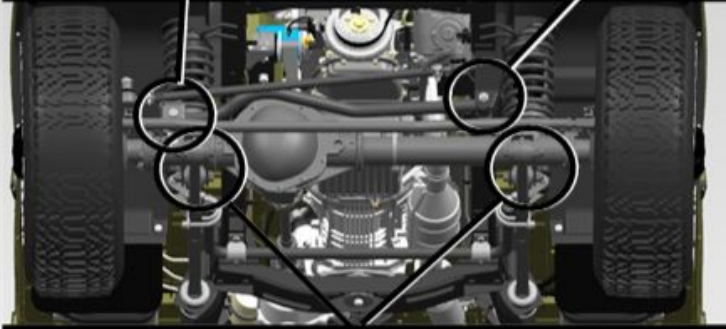

Img 43

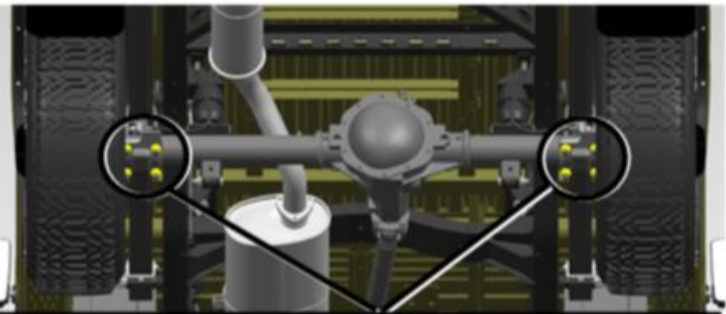

59. Tighten the fastening of the spring ladder nuts.

S=24

tightening torque- 95 N·m

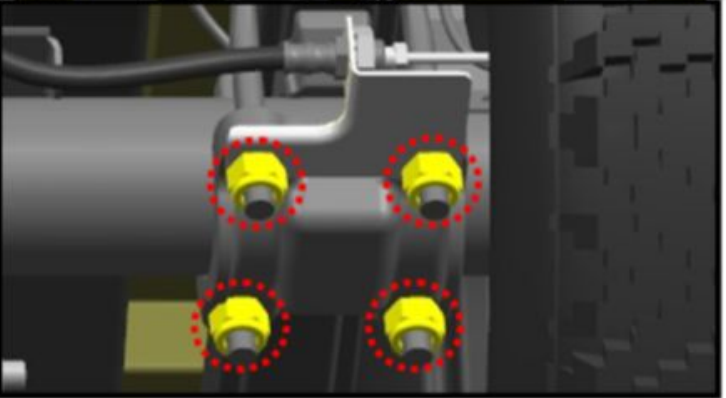

Img 44



60. Inspect the springs.

The springs should not have sheet cracks, their longitudinal or transverse displacement.

61. Tighten the fastening of the axle nuts of the front end of the spring.

tightening torque- 170 N·m

62. Tighten the spring shackle pins.

tightening torque- 90 N·m

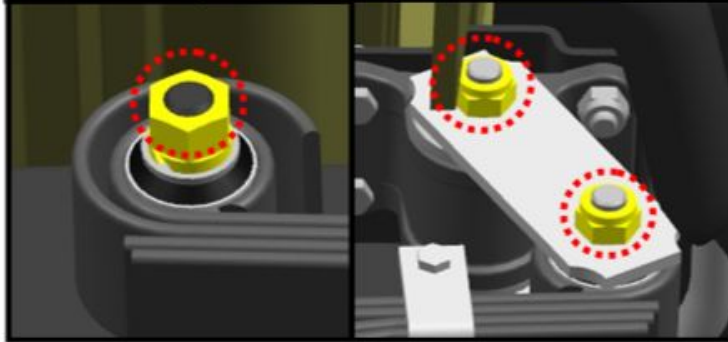

Img 45

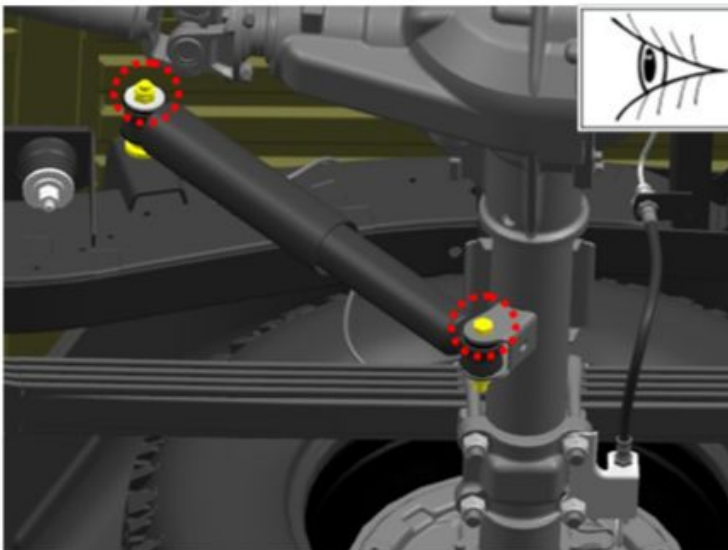

63. Inspect the rear suspension shock absorbers.

Oil fogging of the shock absorber does not indicate a malfunction and is acceptable. The appearance of drips on the shock absorber body, indicating a loss of tightness, is not allowed.

64. Tighten the rear suspension shock absorbers.

tightening torque- 57 N·m

Img 46

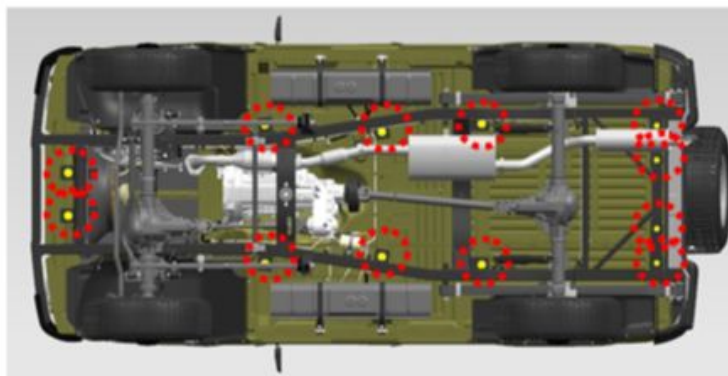

65. Tighten the nuts of the body-to-frame bolts.

S=17

tightening torque- 35 N·m

Img 47

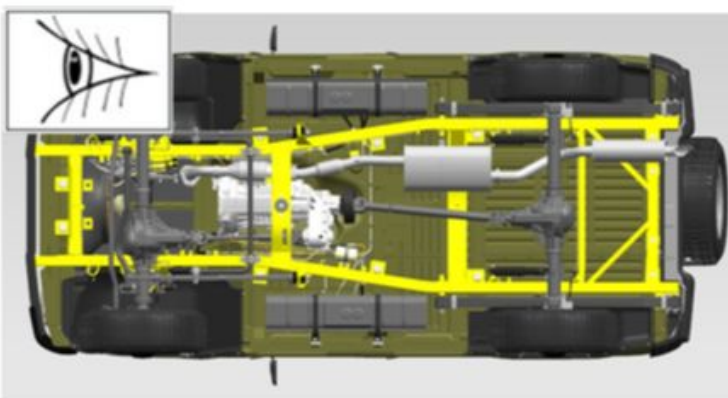

66. Check by inspection the presence of chips, cracks and foci of corrosion of the paintwork of the frame.

The presence of chips, cracks and foci of corrosion of the paintwork of the frame is not allowed.

Img 48

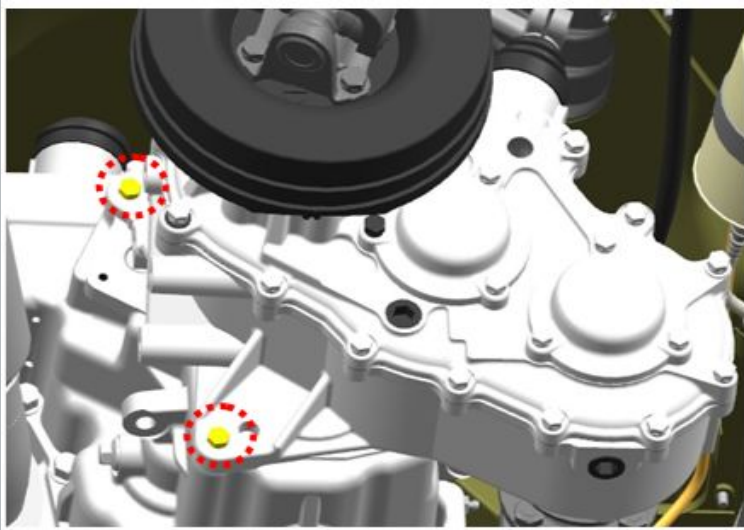

Img 49

67. Tighten the fasteners from the transfer case side.

S=17

tightening torque- 50 N·m

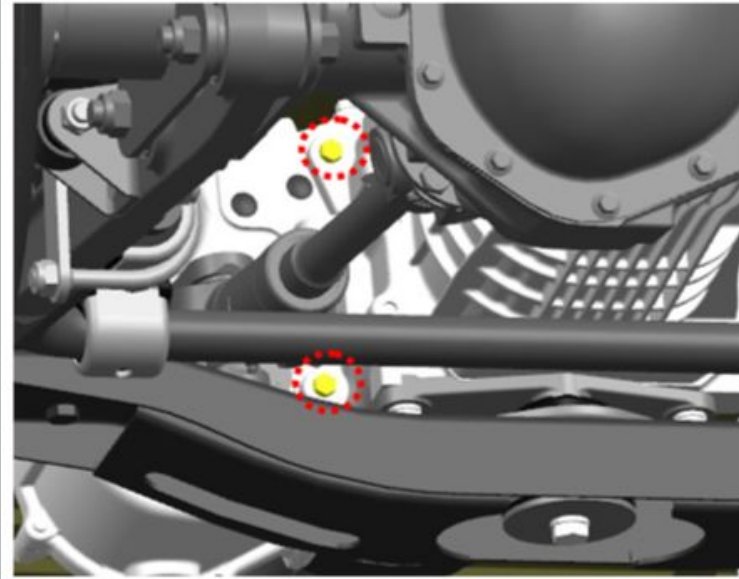

Img 50

68. Tighten the fasteners from the transmission side.

S=17

tightening torque- 50 N·m

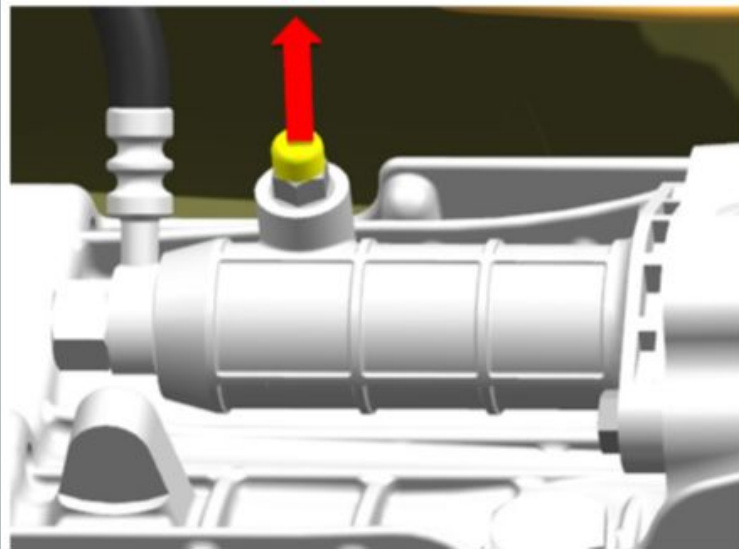

Img 51

69. Remove the rubber cap from the clutch slave cylinder bypass valve.

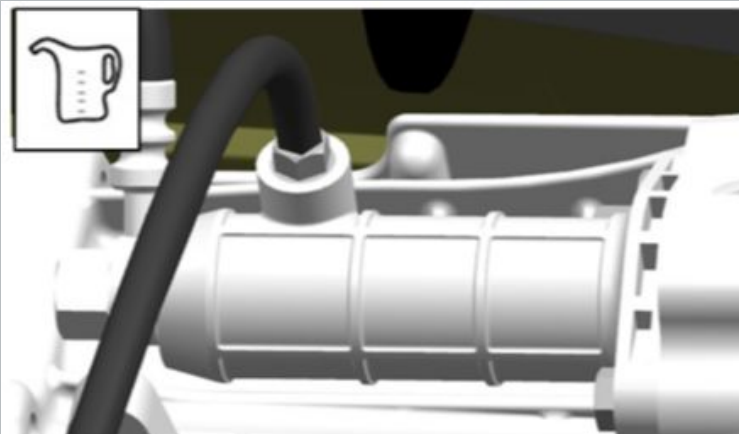

70. Put on the union of the bypass valve of the working cylinder a hose to drain the fluid.

Lower the other end of the hose into an empty process container.

Img 52

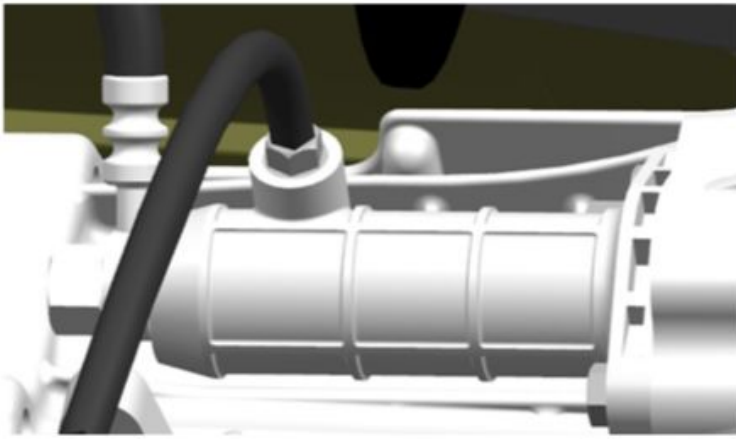

Img 53

71. Pressurize the clutch system by pressing the bleeder valve.

72. Unscrew the bypass valve 1/2 - 3/4 turn.

tightening torque- 12 N·m

73. Release the liquid.

74. Close the valve.

tightening torque- 12 N·m

Let the liquid out until the "new" liquid appears from the bypass valve. The "new" liquid differs from the "old" in a light shade.

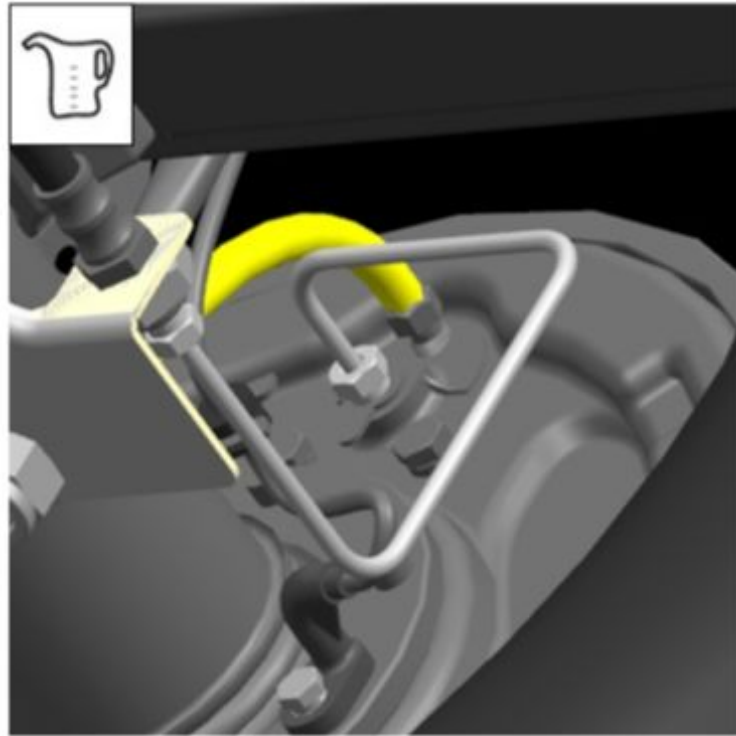

75. Install a hose to the rear right brake bypass valve.

Place the other end of the hose in a container.

76. Pressurize the brake system by pressing the valve on the bleeder.

77. Unscrew the bypass valve 1/2 - 3/4 turn.

tightening torque- 12 N·m

78. Release the liquid.

79. Close the valve.

tightening torque- 12 N·m

Let the liquid out until the "new" liquid appears from the bypass valve. The "new" liquid differs from the "old" in a light shade.

80. Repeat the operations for the rest of the wheels.

Perform operations in the following sequence: - rear left working brake cylinder; - front right working brake cylinder; - front left working brake cylinder.

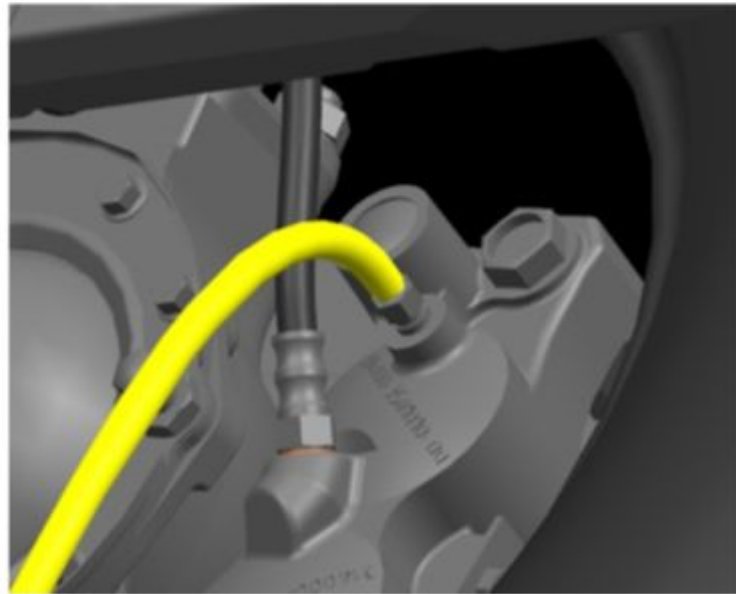

Img 54

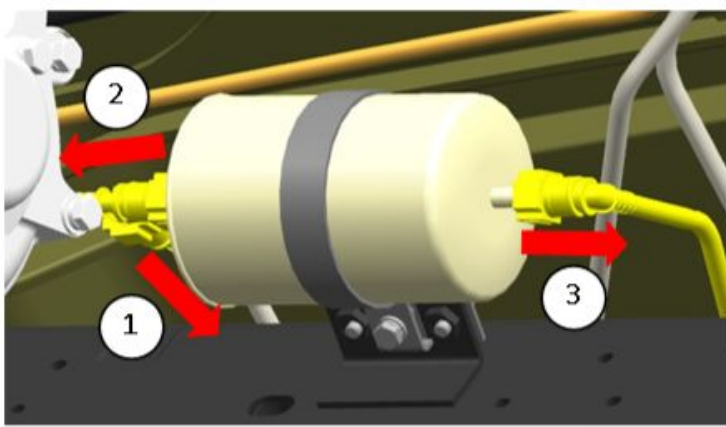

Img 55

81. Disconnect the quick connectors from the fine fuel filter.

Before performing the operation, depressurise the fuel system in accordance with data sheet (00156) (X).

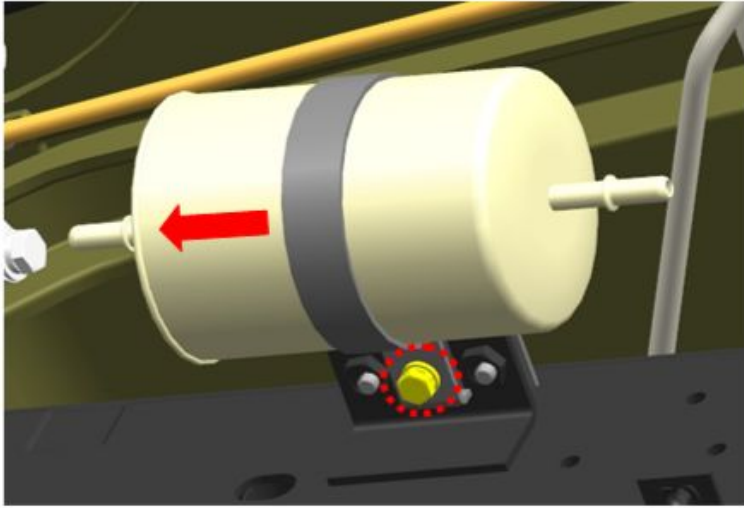

Img 56

82. Unscrew the bolt with washers securing the fuel filter clamp.

S=10

tightening torque- 8 N·m

83. Replace the filter.

Lower the car down on a lift.

4. Work in the engine compartment:

IMAGE

OPERATION DESCRIPTION

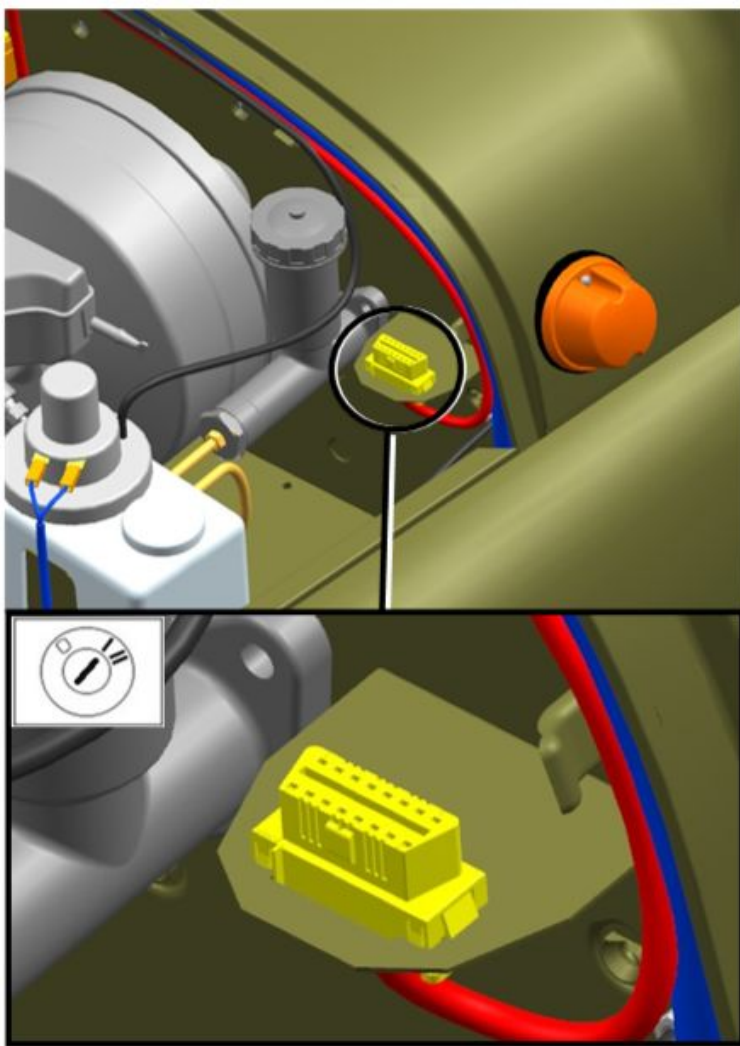

Img 1

1. Connect the UAZ diagnostic system to the OBD-II connector.

2. Switch on the ignition.

3. Check for DTCs in the ECM.

4. Check for fault codes in the ABS control unit.

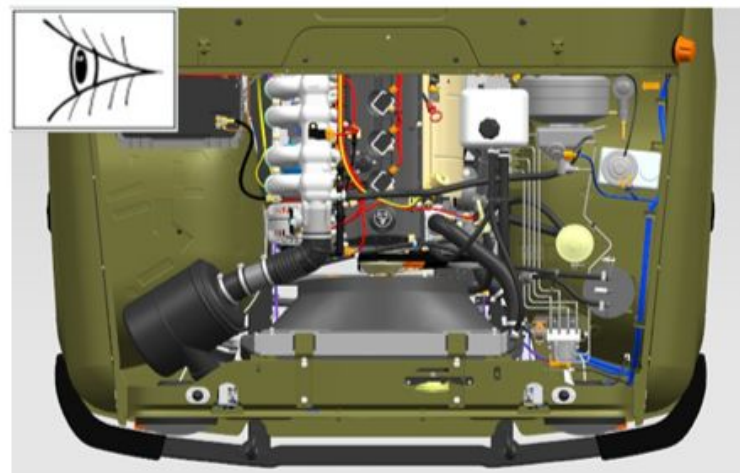

Img 2

5. Carry out an external inspection of hoses, branch pipes, pipes, engine wires.

If there are traces of contact on the parts of the car, change their position relative to the engine. Scuffs and wear on hoses, branch pipes, pipes, wires are not allowed.

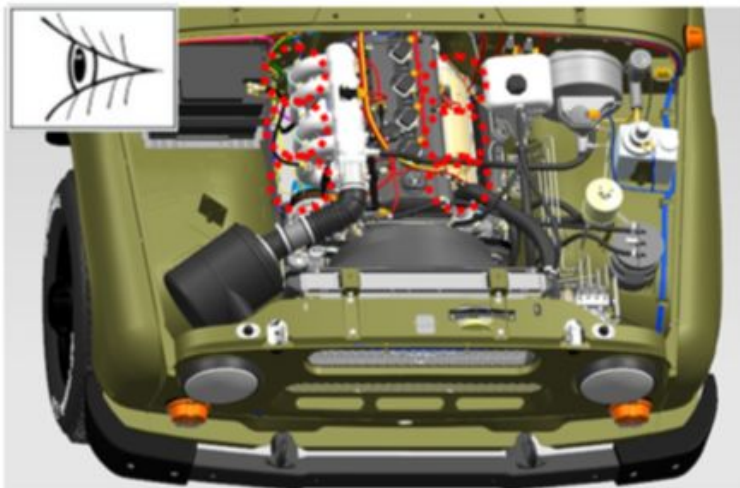

Img 3

6. Visually check the connections of the intake and exhaust systems for leaks.

Leakage of connections is not allowed.

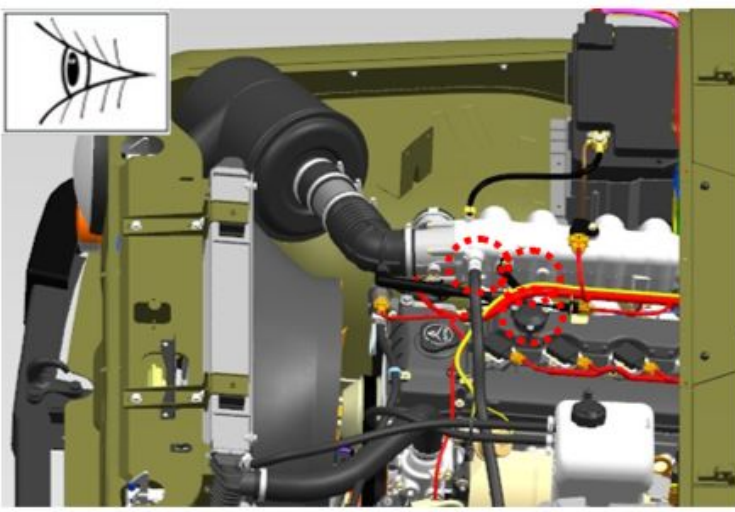

Img 4

7. Visually check the connections of hoses, branch pipes, pipes of the crankcase ventilation system for leaks.

8. Carry out a visual inspection of the hoses for damage.

Leakage of connections and damage to hoses are not allowed.

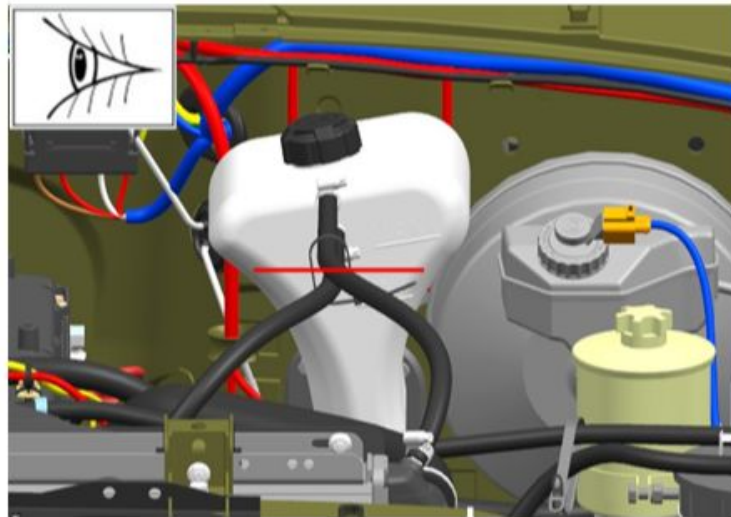

Img 5

9. Visually check the coolant level in the expansion tank.

Check the coolant level only on a cold engine. The liquid level in the expansion tank should be 3-4 cm above the "min" mark.



Img 6

10. Check the freezing point of the coolant with a refractometer.

The freezing temperature of the coolant should be as follows: - for regions with a temperate climate: -40-45 ° C - for regions of the Far North: -60-65 ° C

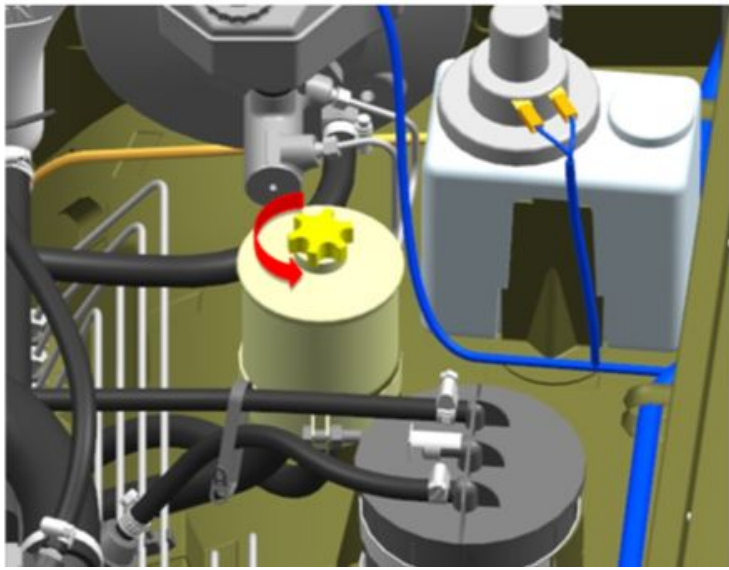

Img 7

11. Unscrew the oil tank cap.

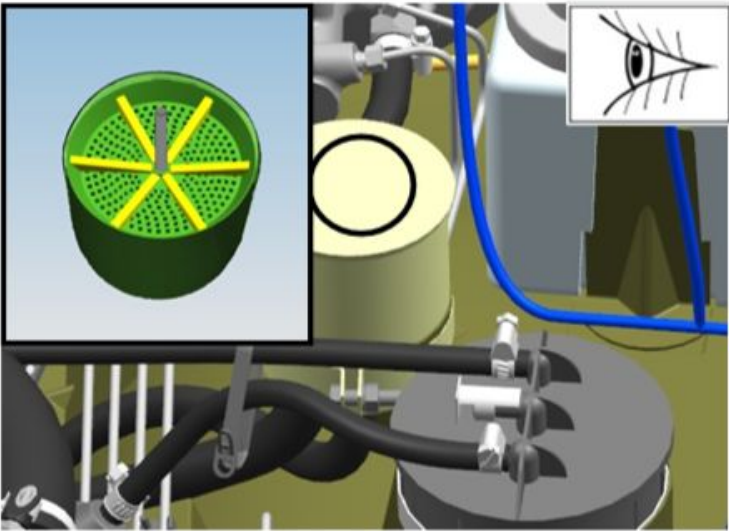

Img 8

12. Check the oil level in the power steering tank.

Fill in oil until it appears above the strainer (no more than 5 mm).

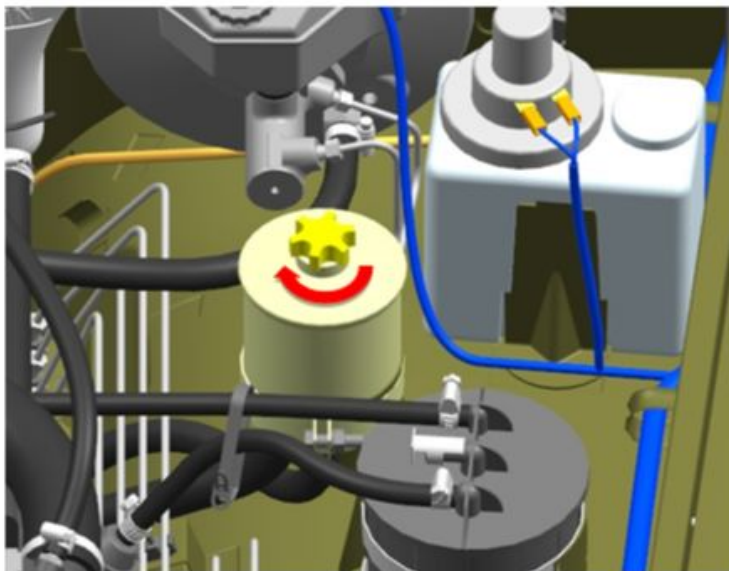

Img 9

13. Install the oil tank cover with a gasket.

14. Tighten the nut with the O-ring of the oil tank cover.

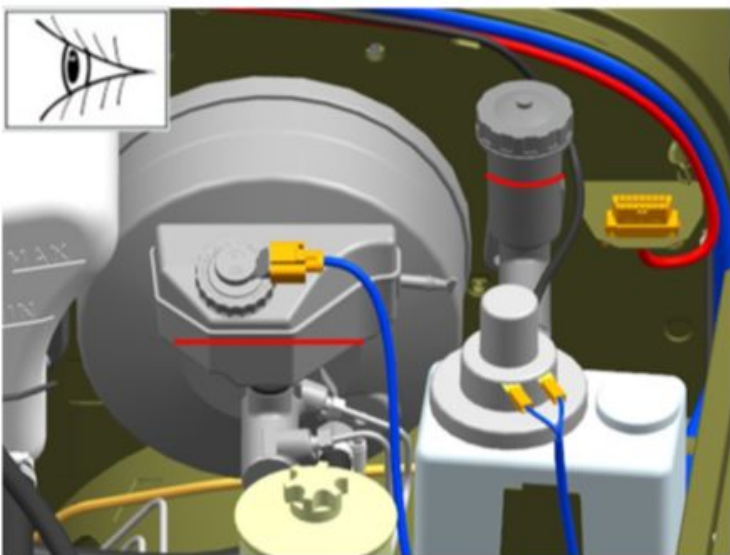

Img 10

15. Check the fluid level in the reservoir of the clutch master cylinder.
The liquid level should be 15-20 mm below the upper edge of the tank.

16. Check the fluid level in the reservoir of the master cylinder of the hydraulic brake.

The brake fluid level should be at the "MAX" mark.

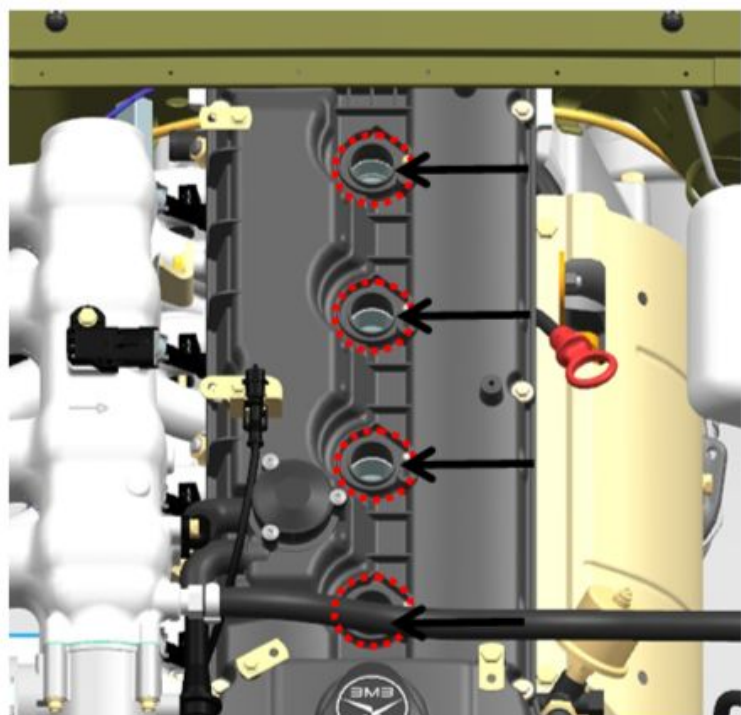

Img 11

17. Remove the spark plugs with sealing rings.

S=16

tightening torque- 35 N·m

18. Install new spark plugs.

tightening torque- 35 N·m

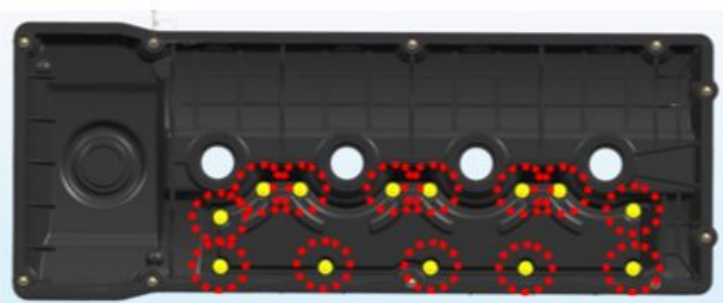

Img 12

19. Remove the screws securing the oil deflector cover.

tightening torque- 5 N·m

To perform the operation, refer to the data sheet "Valve cover - Removal / Installation (10047) (X)".

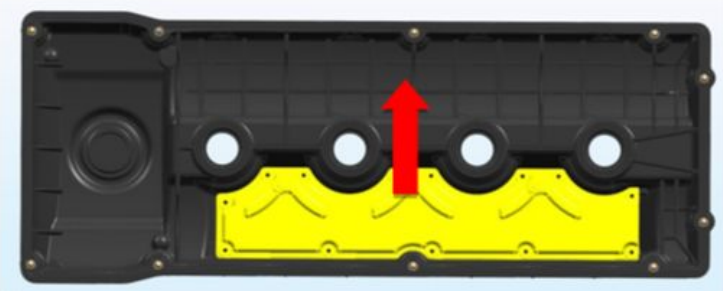

Img 13

20. Remove the oil deflector cover.

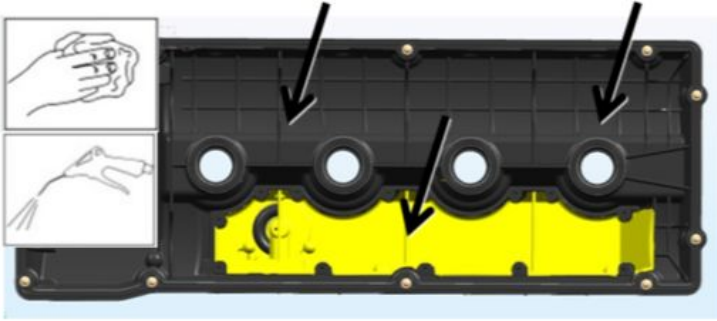

Img 14

21. Clean the parts from resinous deposits, rinse with special fluid and blow out the valve cover and oil deflector with compressed air.

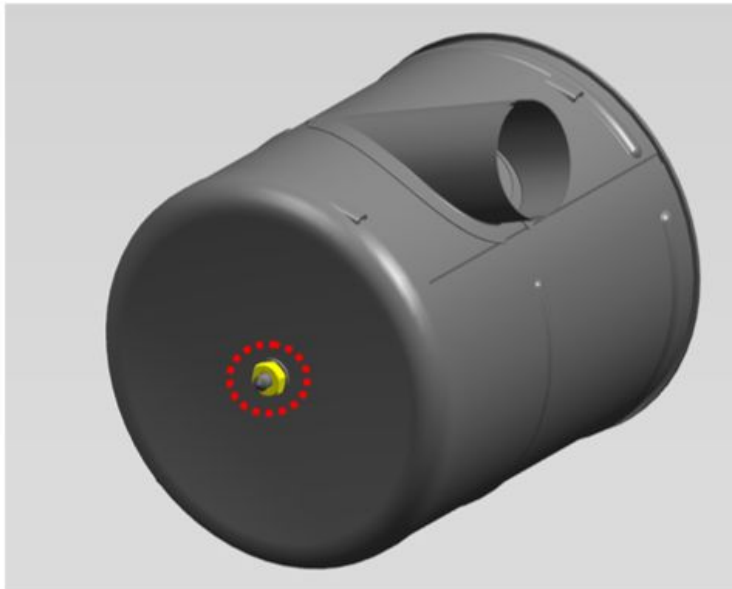

Img 15

22. Remove the air filter.

23. Unscrew the nut with washer.

tightening torque- 15 N·m

To perform the operation, refer to the data sheet "Air filter - Removal / Installation (11014) (X)".

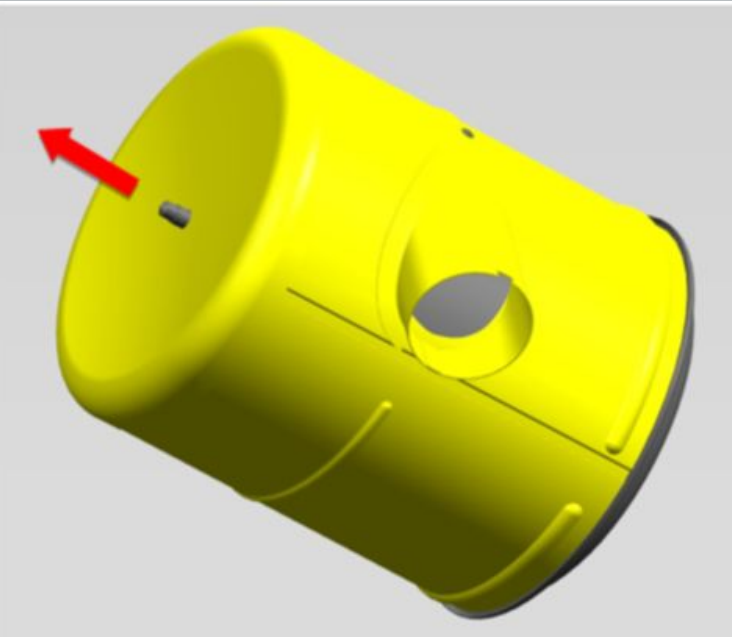

Img 16

24. Remove the air filter housing.

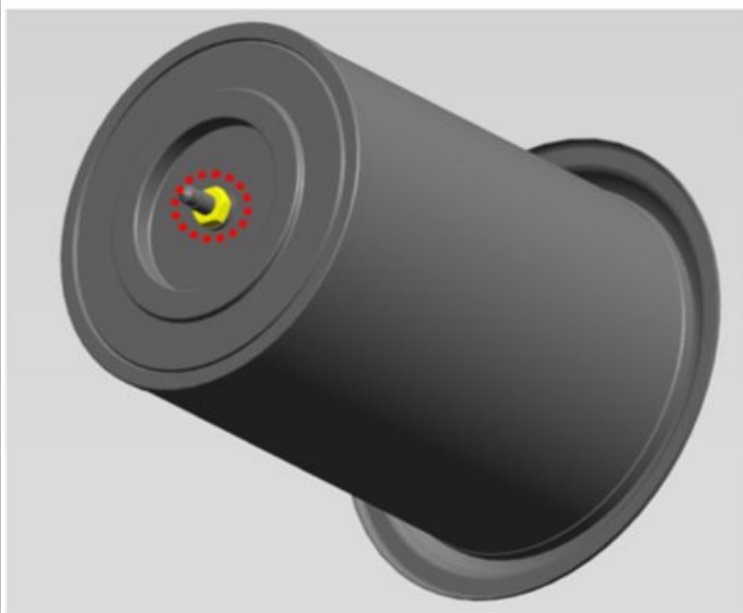

25. Unscrew the nut with washer.

S=17

tightening torque- 15 N·m

Img 17

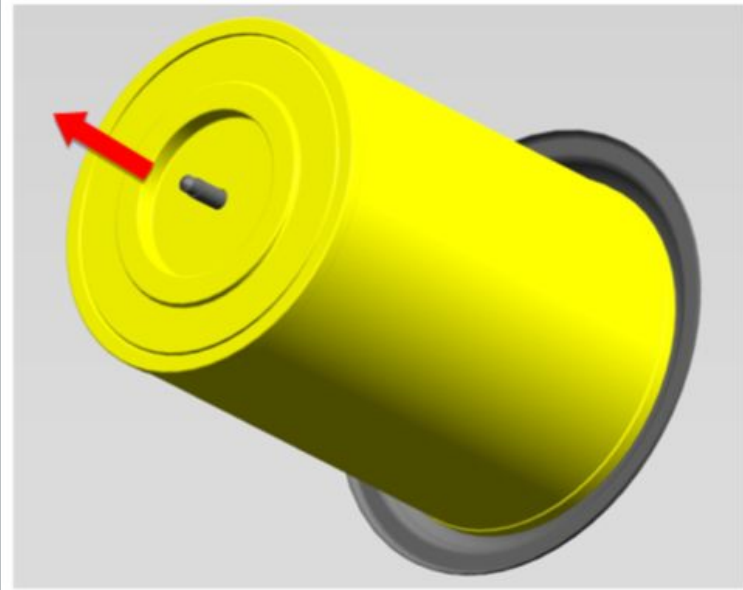

26. Replace the filtering element of the air filter.

Img 18

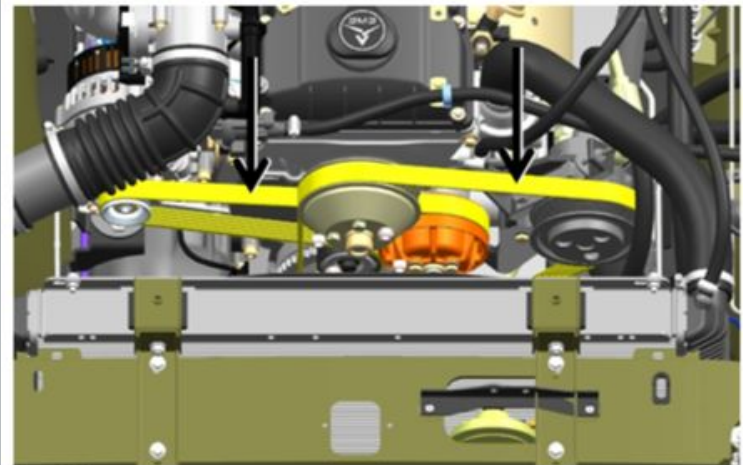

27. Check the tension of the accessory and fan drive belts.

The deflection of the accessory drive belt should be 6-8 mm with a load of 40 N. The deflection of the fan drive belt should be 10-15 mm with a load of 40 N. Damage or excessive stretching of the belts is not allowed.

Img 19

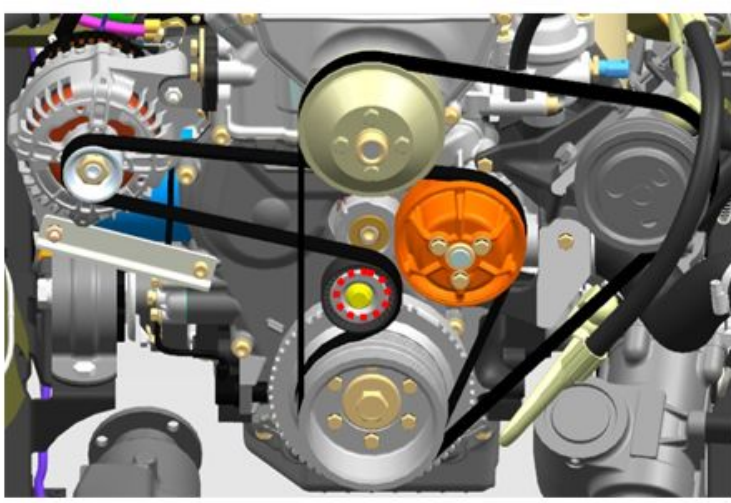

Img 20

28. Tighten the accessory drive belt tension roller bolt.

S=16

tightening torque- 15 N·m



Img 21

29. Tighten the fan clutch mount.

tightening torque- 55 N·m

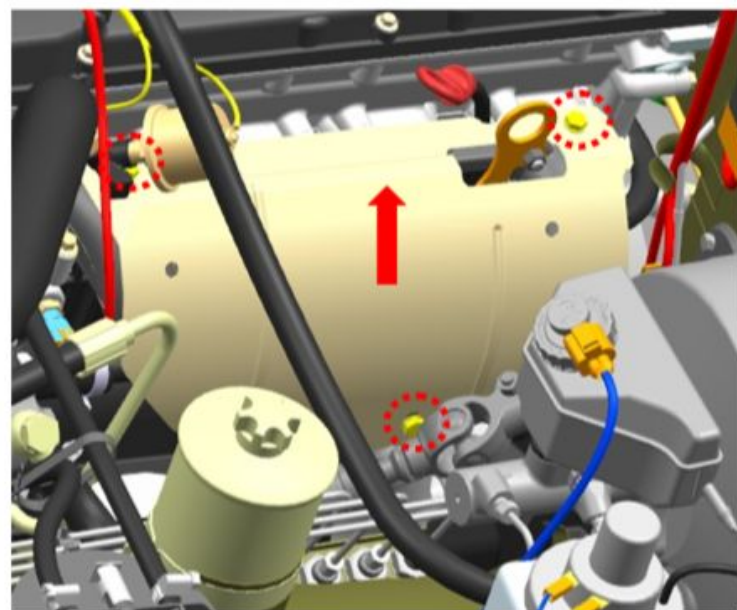

Img 22

30. Remove the bolts with washers that secure the exhaust manifold shield.

S=12

tightening torque- 12 N·m

31. Remove the exhaust manifold shield.

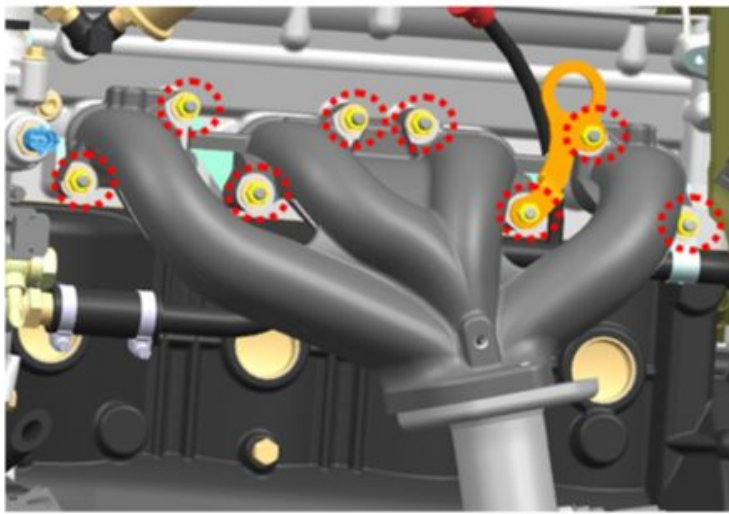

32. Tighten the exhaust manifold retaining nuts and washers.

S=12

tightening torque- 23 N·m

Img 23

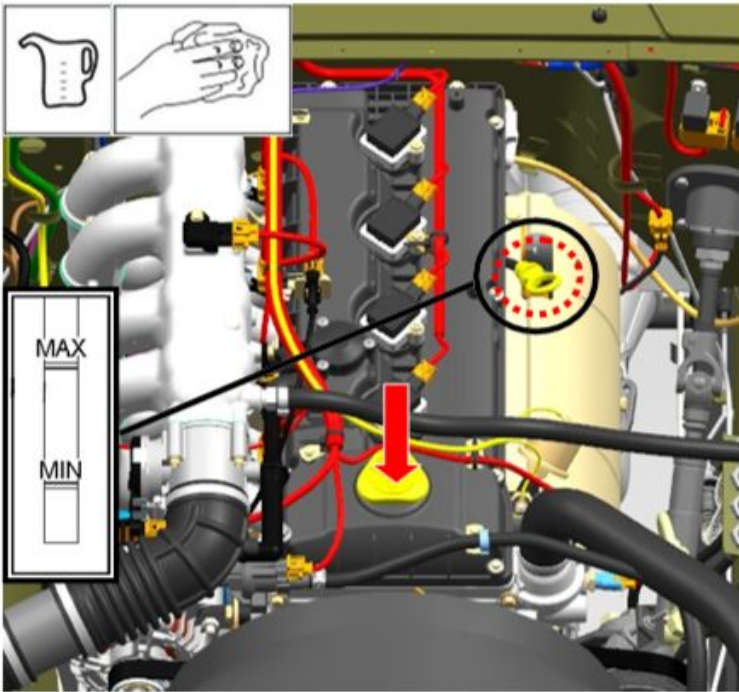

33. Fill the engine with oil up to the upper mark on the oil level indicator.

34. Start the engine.

The engine should be idling for 10 minutes. without increasing the load.

35. Stop the engine.

36. Check the oil level.

Check the oil level after 2 - 3 minutes. after stopping a warm engine. If necessary, add oil to the upper mark.

Img 24

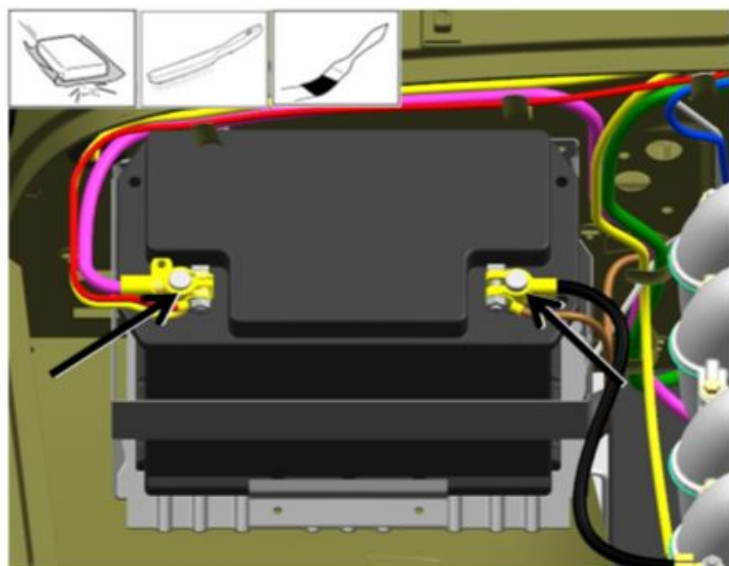

37. Clean the leads and wire tips from oxides.

38. Treat leads and wire ends with a means to protect electrical contacts.

Img 25

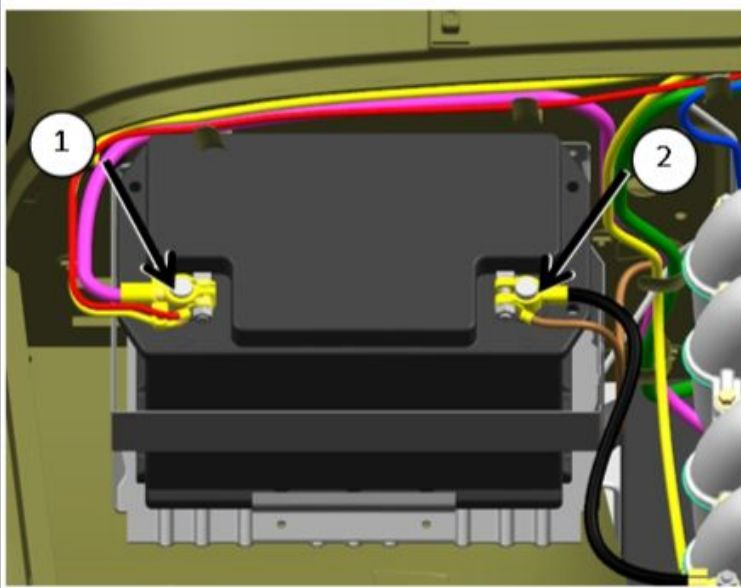

Img 26

39. Connect the terminal of the load plug with "plus" to the same terminal of the battery.

Make the connection without turning on the load coil.

40. Touch the negative pin on the case of the load plug to the negative terminal of the battery.

Record voltmeter readings.

41. Compare the obtained data with the value in Table 2.

If the battery is more than 75% charged, measure under load. If the battery is less than 75% charged, it must be charged.

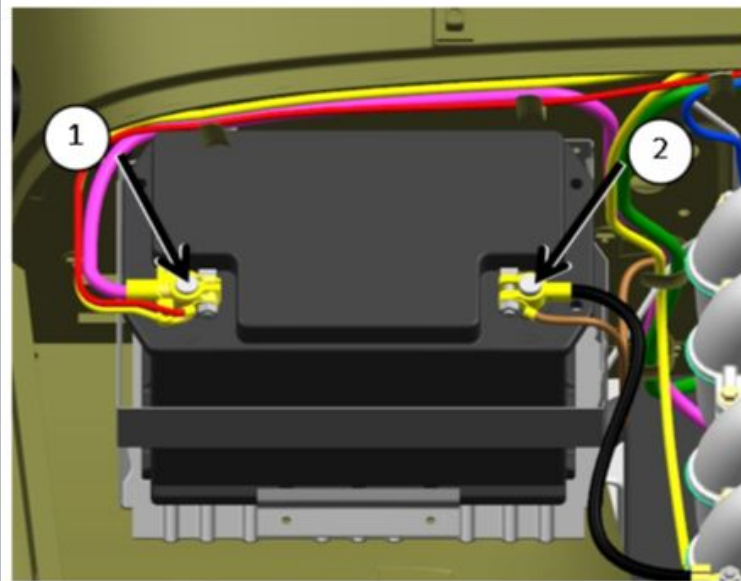

Img 27

42. Switch on the load coil in the load plug, connect its terminal with "plus" to the same terminal of the battery.

43. Touch the negative pin on the case of the load plug to the negative terminal of the battery, and fix the voltmeter readings at the 5th second.

⚠ NOTIFICATION: DO NOT measure for more than 5 seconds.

44. Compare the obtained data with the value in Table 2 and take the recommended actions.



Img 28

45. Fill in the TO-30000 Card for UAZ Hunter vehicles, see Table 3.