

Ulyanovsk Automobile Plant PJSC



Hunter

**Motor Vehicles
UAZ-315195 and UAZ-315148
and Versions Thereof**

Operating Manual
RE 05808600.133-2012
3rd Edition

2016

The Manual contains the necessary rules for operation and maintenance of the motor vehicles.

Please read carefully information given in this Manual. To ensure the fault-free performance of the motor vehicle, please perform all instructions for operation and maintenance specified in it.

The maintenance of the motor vehicle can be performed by one of the service stations recommended by the Manufacturer or by the company, from which you have purchased the motor vehicle. Service stations have all the necessary spare parts, sets of special accessories and tools. All servicing of the motor vehicle is performed by experienced specialists.

Due to continuous work on the improvement of the motor vehicle, the construction may include modifications that are not described in the present edition.

Have a great trip!

Chapter 1. GENERAL INFORMATION

The UAZ-315195 and UAZ-315148 motor vehicles (Fig. 1.1) are light two-axle all-terrain vehicles, with 4WD and a hardtop.

The motor vehicles are designed to transport passengers and cargo over all types of roads and terrain.

The motor vehicles, manufactured in version "U" per Category 1 of State Standard (GOST) 15150, are designed for operation under ambient operating temperatures of -40 up to +40°C, relative humidity of up to 75 % at +15°C, air dust content of up to 1.0 g/m³ and wind speed of up to 20 m/s including in the regions located at absolute elevations of up to 3,000 m, with corresponding reduction of propulsion dynamic performance and fuel efficiency.

The motor vehicles, manufactured in version "T", are designed for operation under ambient operating temperatures of -10 up to +50°C, air relative humidity of up to 80 % at 27°C under conditions specified above for the "U"-version motor vehicles.

The "plus" sign near the part (assembly) description means that this part (assembly) shall be installed into the motor vehicles depending on the configuration.

MOTOR VEHICLE MARKINGS

The vehicle identification number (Fig. 1.2) is embossed on the name plate and on the horizontal flange of the upper panel of the front bodywork (under the motor hood, on the right side).

The motor vehicle name plate (see Fig. 1.2) is located on the center post of the aperture panel on the motor vehicle's right side (in the rear side door opening).

The body number (see Fig. 1.2) is embossed on the horizontal flange of the upper panel of the front bodywork (under the motor hood, on the left).

The chassis number (see Fig. 1.2) is embossed on the right side frame (in the rear part of the vehicle).

The engine identification number (Fig. 1.3) is located on the engine's cylinder block on the left side.

Fig. 1.1. Basic dimensions of UAZ-315195 and UAZ-315148 hardtop motor vehicles (dimensions are given for reference)

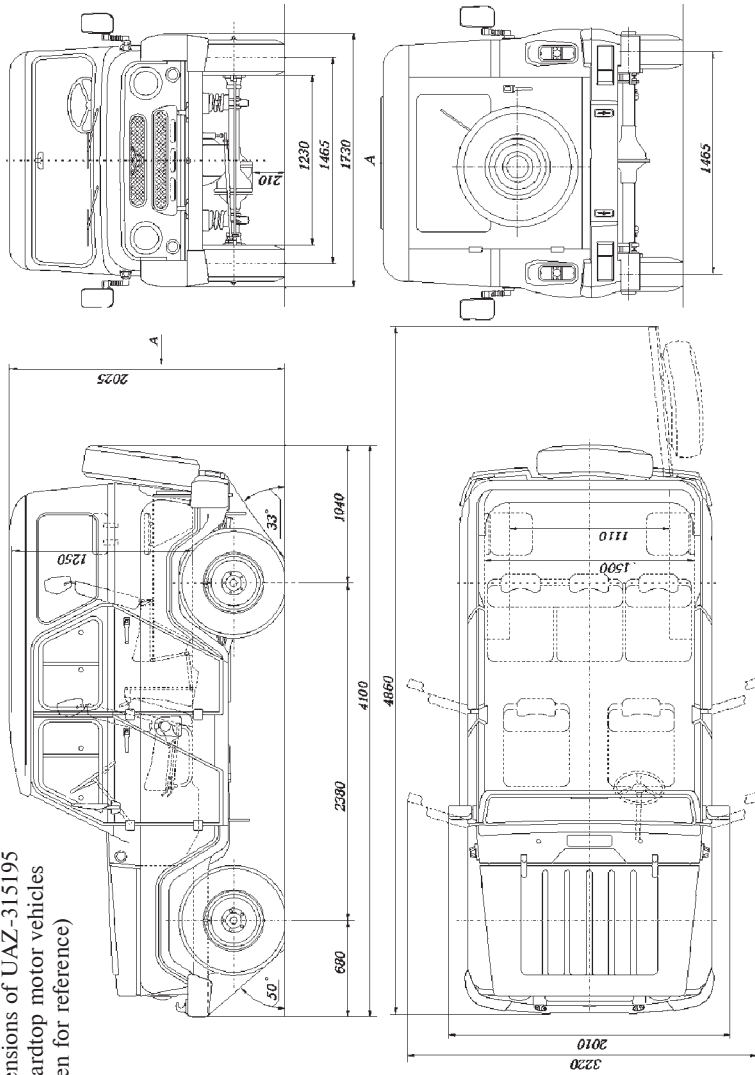

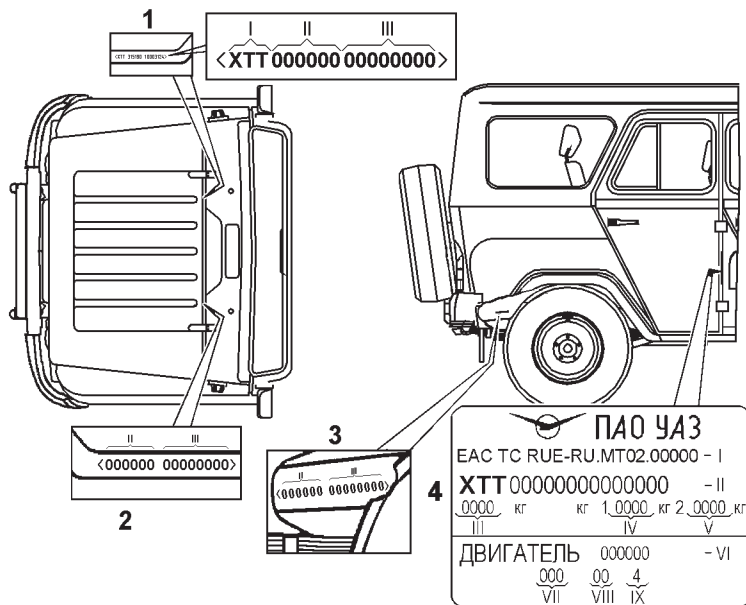

Fig. 1.2. Vehicle markings:

1 — Vehicle Identification Number; 2 — body identification number; 3 — chassis identification number; 4 — vehicle name plate; I — complete number of Vehicle Type Approval (VTA); II — Vehicle Identification Number (VIN code); III — maximum allowed vehicle weight; IV — maximum allowed front axle load; V — maximum allowed rear axle load; VI — engine model designation; VII — configuration code; VIII — offset code

I — the Vehicle Description Section (VDS) consists of six symbols with the first five symbols (digits) designating the engine model. If the engine model designation includes less than five digits, zeros shall take the place of blanks. The sixth symbol (zero or letter) designates the engine configuration option; II — the Vehicle Identification Section (VIS) consists of eight symbols. The first symbol (letter or digit) designates the year of manufacture of the engine, the rest of the symbols (digits) stand for the engine serial number.

The information plates are located on the inside of the left sun visor.

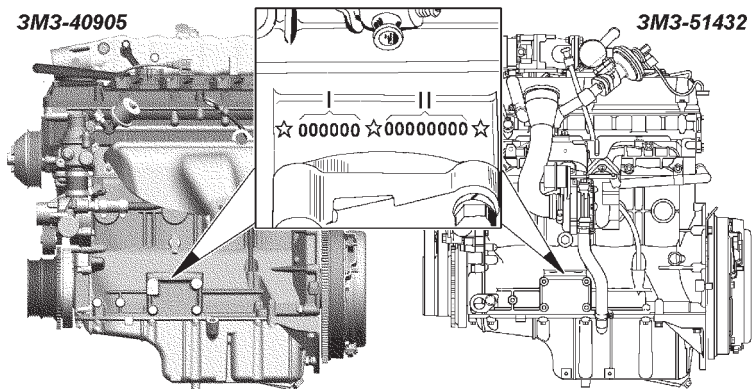

Fig. 1.3. Location of the engine identification number

TECHNICAL SPECIFICATIONS

Description	UAZ motor vehicle models	
	315195	315148
	1	2
	GENERAL DATA	
	Dimensions are shown in Fig. 1.1	
Motor vehicle type	All-terrain, two-axle, 4WD axle configuration	
Seating capacity (including driver's seat)	5	5
Maximum load capacity (incl. driver and passengers), kg:		
for operation on roads with good pavement	750	735
for operation on other roads and terrain	550	535
Motor vehicle allowable gross weight, kg:		
for operation on roads with good pavement	2520	2550
for operation on other roads and terrain	2320	2350
Gross weight distribution by axles, kg:		
for operation on roads with good pavement:		
front axle load	1020	1020
rear axle load	1500	1530

7

1	2	3
for operation on other roads and terrain:		
front axle load	970	985
rear axle load	1350	1365
Vehicle's curb weight ¹⁾ , kg	1845	1890
Curb weight distribution by axles, kg:		
front axle load	1010	1020
rear axle load	835	870
Maximum speed, km/h	130	120
Fuel consumption in motion at constant speed of 90 km/h, L/100 km	13.2	10.6

8 **Note.** Fuel consumption value is used to determine the motor vehicle technical condition and shall not be regarded as the operation standard. Fuel consumption measuring accuracy is only ensured in special testing conditions and in strict compliance with the requirements of GOST 20306-90, when the motor vehicle total mileage reaches 9,000-10,000 km

Gross weight of towed trailer, kg, max:	
one equipped with brakes	1500 ²⁾
one without brakes	750 ²⁾
The least turning radius along the front external (relative to the turning center) wheel trace axis, m, max	6.5

¹⁾ Filled with fuel and lubricants, tools, additional accessories, spare wheel, and by driver

²⁾ Towing a trailer shall only be allowed if there is present a ball-type tow unit, certified as part of a tractor-trailer unit, as per the established procedure

6

1	2	3
The least turning radius, external by the front bumper point, outermost of the turning center, m, max		7.0
Maximum climb for a motor vehicle of gross weight, degrees (%)		31 (60)
Maximum fordable depth, m: unprepared prepared		0.5 0.7
	ENGINE	
Version	ZMZ-40905	ZMZ-51432
Type	4-stroke with spark-plug ignition	diesel turbo engine with direct injection
Number of cylinders		four
Cylinder arrangement		row, vertical
Ignition sequence		1-3-4-2
Cylinder diameter, mm	95.5	87
Piston stroke, mm	94	94
Engine displacement, L:	2.693	2.235
Compression ratio	9.1	19
Minimum crankshaft rpm at idle, min ⁻¹	800-900	850-900
Maximum torque, N · m (kgf · m) as per UNECE Rules 85 (GOST R 41.85)	209.7 (21.4) at 2,400-2,600 min ⁻¹	270 (27.5) at 1,300-2,800 min ⁻¹

1	2	3
Output, kW (hp): net as per UNECE Rules 85 (GOST R 41.85)	94.1 (128) at 4,600 min-1	83.5 (113.5) at 3,500 min-1
Lubrication system	Combined: force-feed and centrifugal	
Case ventilation	Closed	
Fuel system	Multipoint fuel injection with electronic control	Direct fuel injection by
Fuel	Unleaded gasoline "Regular-92" (AI-92-4) GOST R 51105, AI-92-K4 GOST 32513 and AI-92V GOST RV 9130-001 Allowed: Premium Euro-95 type II (AI-95-4) and Super Euro-98 type II (AI-98-4) GOST R 51866, AI-95-K4 and AI-98-K4 GOST 32513.	Diesel fuel as per GOST R 52368 (EN 590:2009), of grades A, B, C, D, E, F, of classes 0, 1, 2, 3, 4, types II and II in accordance with operating conditions
Cooling system	Liquid, closed-loop forced circulation	
TRANSMISSION		
Clutch: clutch type drive type	Dry, single-disc Hydraulic	
Transmission gear box: gearbox type	Mechanical, synchronized, five-speed by Dymos Company or made in China	
control type	Mechanical	
Transfer gear box: gearbox type control type	Two-speed Mechanical	

1	2	3
power take-off	Possible for the drive (during motor vehicle motion and standstill) of special units installed within the body, with power take-off box to be installed by the Customer. Allowed power take-off is 40 %. Installation of power take-off box should be approved by UAZ PJSC.	
Drive line	Open-type, consists of two shafts. Each shaft has two universal joints with spiders on needle bearings.	
Front and rear driving axles: axle type axle differential front driving axle steering pivots	<p style="text-align: center;">Single-stage Conical, with 4 pinion gears Ball-type constant velocity joints</p>	
CHASSIS		
Suspension: suspension type shock absorbers	Conventional, front — coil suspension with the stabilizer bar, rear — on two longitudinal semi-elliptic leaf springs. Four hydraulic dual-action telescopic.	
Wheels and tires: wheels	Undivided type disc wheels, fastening — five nuts. Steel, tire rim size is 6 1/2 Jx16 with projection of 40 mm, or of light alloys, tire rim size is 7Jx16 with projection of 35 mm. Spare wheel is attached to the holder by three nuts, or one bolt on motor vehicles with tailgate	
tires	Air radial tubeless tires, size 225/75R16	
CONTROL SYSTEMS		
Steering system: steering type	hydraulic power "Screw-ball nut-rack-sector"	
Brakes: brakes	disc brakes on front wheels and drum brakes on rear wheels	

1	2	3
brakes drive type parking brake parking brake drive type	Hydraulic drive with vacuum booster, split for front and rear wheels Drum with inboard shoes Mechanical	
ELECTRIC EQUIPMENT		
Wiring system Grid voltage (rated), V Alternator	Single-wire, negative pole connected to the motor vehicle "ground" 12 AAK 5730 14V 80A by Iskra Company; 5122.3771 14V 80A by Pramo-Elektro Company; 3212.37771 14V 90A JSC BATE	
Rechargeable battery Spark plugs	6CT-66 AU14DVRM GOST R 53842, DR17YC-F by BRISK Company	6CT90A -
Heating plugs	-	0250 202 045, by BOSCH Company 0100 226 573, by BERU Company
Starter	6012.3708 by ZIT CJSC; AZE 2154 12V 1.9 kW by Iskra Company; AZE 2203 12V 1.9 kW by JV Pramo Iskra LLC; DW-12V, 2.0 kW by BOSCH Company	
Ignition switch Windshield wiper Rear window wiper+ Window washer	With anti-theft system and starter re-ignition lock, Electrically driven with two brushes, tri-mode Electrically driven with one brush Electrically driven, for windshield and rear window+	

12

1	2	3
ADJUSTING VALUES		
Hydraulic booster fan and pump belt deflection at force of 4 kgf, mm	10-15	8-12
Cooling system electric generator and pump belt deflection at force of 8 kgf, mm	-	-
Gap between spark plugs electrodes, mm	0.7+0.15	-
Brake pedal free play, mm	5-8	-
Front wheel toe-in	0°4'-0°10'	
Front internal wheel maximum steering angle, degrees	26-27	
Steering system total clearance (steering wheel's steering angle from the position corresponding to the steering wheels wedge in one direction to the steering wheel position corresponding to the steering wheels wedge in the opposite direction), degrees, max	20	
TIRE PRESSURE, MPA (KGF/CM2)		
Front wheels	0.20 (2.0)	
Rear wheels	0.25 (2.5)	

1	2	3
FUEL DATA (in liters)		
Fuel tanks:		
right-side		35
left-side		35
Motor vehicles' engine cooling system		12.5
Engine lubrication system		6.5
Transmission gearbox case:		
Dymos		2.5
made in China		1.7
Transfer gearbox case		0.8
Main drive case front/rear		1.5/1.4
Steering mechanism hydraulic		
booster case		1.1
Clutch hydraulic drive system		0.18-0.20
Windshield washer reservoir		2.2
Rear window + washer reservoir		2.2
Brakes hydraulic drive system		0.60

Chapter 2. SAFETY REQUIREMENTS AND WARNINGS

SAFETY REQUIREMENTS

1. *During operation of the motor vehicle, it is necessary to observe the traffic rules and safety requirements, and maintain the motor vehicle in good condition with timely maintenance and elimination of possible malfunctions, in order to avoid injuring oneself and others.*

2. *The driver shall be responsible for passengers, and he/she must monitor observance of safety rules by the passengers. Take special care if there are children in the motor vehicle. Do not leave children unattended in the motor vehicle.*

3. *It is prohibited to turn ignition off and remove the key from the ignition starter switch while the motor vehicle is moving. Stopping an engine will lead to reduced braking capacity, and the steering system shaft will be blocked by the anti-theft device if the key is removed, and then the motor vehicle becomes uncontrollable.*

4. *When exiting the motor vehicle, do not leave the door and ignition keys inside.*

5. *Prior to opening the door, make sure that it will not cause hindrance for other road users.*

Prior to closing the door, make sure it will not pinch someone or something.

The motor vehicle shall not be driven if any door or tail board is open.

Prior to travel, check good operating condition and the security of closing of locking mechanisms of the hood, the body doors and the spare wheel holder.

6. *Safety belts are effective means to protect the driver and passengers against severe consequences in case of traffic accident.*

Use of safety belts is mandatory!

7. *Worn or damaged tires, under-inflated or over-inflated, warped wheels, or loosened wheel fasteners can cause an accident.*

8. *Please remember that when the engine is off, required force to turn the steering wheel and apply brakes increases significantly.*

9. *If the brake system or the steering system is inoperative, it is prohibited to further drive, or to tow the motor vehicle with a flexible cable or chain. In such case, tow the motor vehicle by using a wheel-lift apparatus or engage a flatbed tow truck.*

10. *For the diesel-engine motor vehicle:*

- after a long period of rest (over 1 hour), start moving only 20 to 30 seconds after the engine starts, to let the vacuum pump create in the vacuum brake booster the sufficient negative pressure for proper braking;

- to ensure efficient braking, do not allow a reduction of the engine idle rpm below 850 min^{-1} .

11. It is strictly prohibited to disassemble shock absorbers.

12. To prevent carbon monoxide poisoning, do not warm the engine up in a closed premises, lacking sufficient ventilation.

13. Do not warm motor vehicle units with open flame.

14. Keep the engine clean (engine grease, especially in its crankcase, can cause fire).

15. Make sure that the fuel tank caps are closed tightly and there are no leaks from the fuel lines.

16. The converter operating temperature shall be $400\text{-}800^\circ\text{C}$. The motor vehicle may not be operated if no protective screen is installed on the converter. During motion of motor vehicle and when standing still, ensure that the exhaust system has no contact with flammable materials (e.g., dry grass).

17. When handling antifreeze fluids, fuel or the brake fluid, please observe the following rules:

- avoid any operations resulting in the ingress of these fluids or their vapors into your mouth;

- in case of skin contact, immediately wash the fluid away with water and soap;

- prevent the spillage of fluids in the motor vehicle or a closed room. The contaminated place must be flushed with water and ventilated;

- clothing contaminated with fluid must be dried outdoors prior to washing;

- moisten the gasoline soot with kerosene when scraping, to avoid ingress of the soot toxic substances into your respiratory system;

- when handling fuel, observe fire safety rules.

18. Upon stopping, the motor vehicle shall be secured with the parking brake.

19. Take special precautions when handling electrolyte. To prevent poisoning and chemical burns, observe the following rules:

- strictly adhere to safety requirements specified in the rechargeable battery operating guidelines;

- electrolyte or its vapors coming in contact with the mouth, respiratory system, or eyes is extremely dangerous;

- avoid any operations that can result in contact of the electrolyte with your skin. In case of a contact, carefully wipe it off with cotton wool and immediately rinse the remaining traces from your skin with a 5 % solution of ammonia or sodium carbonate;

- spilled electrolyte shall be collected using a special syringe or hydrometer, flush off with water, ventilate the room;

- to charge the battery, dismantle it from the motor vehicle and unscrew the filler plugs;

- the battery must be charged in a well-ventilated room. Accumulation of electrolyte vapors is hazardous to health and presents an explosion hazard.

20. Do not wash motor vehicle while the engine is running.

21. An improperly installed lifting jack can cause serious injury or damage to the motor vehicle. It is strictly prohibited to carry out works under a motor vehicle supported only by the lifting jack.

22. On steep descents, you may not:

- disengage the clutch to avoid breakdown of the driven disc;

- drive with steps disengaged in the gearbox and the transfer case;

- shut off the engine due to loss of braking capacity.

23. During the motor vehicle maintenance and routine repairs, the following requirements shall be met:

- prior to commencing work, check the condition of tools and attachments, arrange the work clothing: button up cuffs, tuck the clothing in such a way that no hanging ends are present, tuck the hair under tight-fitting headgear;

- for performing any work, the motor vehicle must be securely blocked to prevent movement;

- do not perform any motor vehicle maintenance and repair while the engine is running, except for certain types of works, the performance of which requires that the engine be running — in such case, take particular care;

- do not place your hands, clothing, tools too close to the moving drive belt, pulley, etc.;

- the fuel feed system downstream of the fuel pump with the engine running is pressurized, so no maintenance (e.g., tightening of joints) or repair of the system assemblies is allowed with the engine running or immediately after a stop;

- take care when opening the engine cooling system cooler cap to avoid being scalded by the steam;

- prior to electric arc welding, be sure to dismantle fuel tanks;
- observe fire safety rules.

24. Used oils and special liquids must be collected and sent for recycling or disposal.

25. Several safety requirements are detailed in the respective sections of this Manual.

WARNINGS

1. During the initial operating period, all the recommendations specified in the section "Running the New Motor Vehicle" must be strictly observed.

2. Do not drive off with cold engine. Avoid high crankshaft rpm after a cold start.

Warming up the engine at high crankshaft rpm for faster heat-up is forbidden.

To avoid any difficulties during engine start, strictly observe instructions specified in the section "Engine Start".

3. When abnormal noises and knocks arise in the running engine, the cause should be investigated. Do not operate the motor vehicle until the fault is eliminated.

3.1. Upon cold start, knocking in hydraulic pushers of valves may arise, caused by the suction of the air into the high-pressure chambers of hydraulic pushers. Typically, these phenomena appear in the following cases:

- cold start;
- multiple starts (after several unsuccessful starts);
- engine start after a long time of standing still.

To remove the air, the engine must be warmed up to the cooling fluid temperature of 80-90°C. Let the engine run at constant rpm of $2,500 \pm 100$ rpm or at variable rpm within 2,000-3,000 rpm for 3-4 minutes, then listen for 15-30 seconds the operation of the engine when running idle. If the knocking persists, repeat the cycle up to 5 times. If the knocking persists after the above procedures are completed, you need to contact a service station to eliminate the malfunction.

4. To ensure reliable operation and to prevent accelerator pedal failure, we recommend:

- not to apply excessive loads to the pedal lever after its operating stroke ends;

- avoid impact, lateral and other loads that are not appropriate for the working stroke of the pedal.

5. Only engage the reverse speed in the gear box and the low speed in the transfer case after the motor vehicle has come to a full stop.

6. When driving along dry hard roads, the front axle must be disengaged.

Avoid engaging of the front axle when driving the motor vehicle with small turning radii.

7. In case of failure of any brake circuit, the brake pedal stroke increases and braking capacity decreases.

8. Please remember that for the diesel-engine motor vehicle, in case of frequent pressing of the brake pedal (after the pedal is released, it is pressed again immediately) the vacuum pump may not have enough time to create the required negative pressure, causing the braking capacity to decrease, and it will be necessary to apply an increased force to the brake pedal.

9. While the engine is running, the metal segments may not be removed and check that the sparking discharge is "grounded".

10. Prevent contact of acids, soda solutions, brake fluid, anti-freeze and lubricants with the body's painted surfaces and rubber parts.

11. Prevent the motor vehicle suspension system from being subjected to impact loads. In case of heavy impact with front wheels, inspect thoroughly the wheels, all the components of the front axle, steering links, steering system, the engine oil casing, and eliminate the revealed defects.

12. To prevent excessive loads on the axle differential, avoid long-term spinning of one of the wheels.

13. For the motor vehicle operation in the cold season (ambient temperature of 0°C and below), we recommend to using a cold-weather cover for the radiator cowl.

To eliminate freezing of the engine crankcase, the ventilation system connecting the pipe, at ambient temperature below (-15°C), disconnect the resonator-type hose from the air filter, turn the filter counter-clockwise against its stop (the air filter inlet pipe will be directed backward and downward).

14. Store the rechargeable battery in a heated room if the vehicle will be standing still for more than 12 hours at ambient temperature below -30°C.

15. *To prevent steering pump failure and oil overheating while driving, it is not recommended to hold the steering wheel in extreme positions for more than 20 sec.*

16. *Use only the recommended lubricants and special-purpose fluids specified in the warranty and service book.*

17. *Do not start the engine if the low-voltage wires are installed improperly to ignition coils.*

18. *When using a lubrication gun with nozzle unscrewed, remove the spring and the ball to avoid their falling into the units containing liquid lubricants.*

19. *When the tail gate of your motor vehicle is opened, other traffic participants cannot see the rear lighting devices. Prior to opening the T-gate, place a warning triangle on the road as per GOST R 41.27-99.*

20. *The long-term and fail-safe operation of the motor vehicle depends on how accurately you observe the requirements stipulated in this Manual.*

21. *For tightening torques for main threaded joints, see Appendix 2 to this Manual.*

22. *The Manufacturer constantly works on improving the construction of its motor vehicles, and therefore the latest design changes, which do not affect performance, may be absent from the present edition of the Manual.*

Chapter 3. CONTROLS AND EQUIPMENT IN DRIVER/PASSENGER COMPARTMENT

For driver seat location of controls and equipment, see Fig. 3.1:

1 — steering wheel;

2 — **headlights** manual adjuster. The headlights beam inclination is adjusted by rotating the adjuster lever, depending on the motor vehicle load:

■ ■ — a motor vehicle with a driver;

■ ■ — all seats occupied;

■ ■ □ — a motor vehicle with a driver and maximum allowed load in cargo compartment.

Adjust the headlights strictly by marks in accordance with the load. For other loading options (when gross weight is not exceeded), select the position in the way that the road illumination by low beams is within the set standards, without blinding oncoming transport drivers;

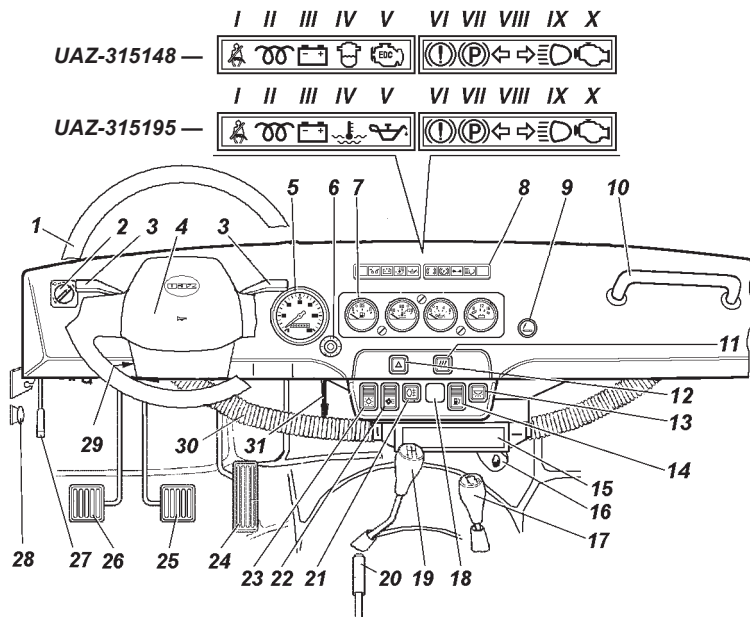

Fig. 3.1. Controls, and passenger seat equipment
(for positions names, see the relevant text)

3 — levers of multi-function under-the-steering wheel switch (for lever positions, see Fig. 3.2);

Turn signals and headlight beams switch lever (see Fig. 3.2a) has the following positions:

I — turn signals are off; low beam is on if headlights are switched on by the external illumination switch;

II — left turn signals are on (unstable position);

III — left turn signals are on (stable position);

IV — right turn signals are on (unstable position);

V — right turn signals are on (stable position);

VI (pull) — high beam is on regardless of the external illumination switch position (unstable position);

VII (push) — high beam is on if headlights are switched on by the external illumination switch (stable position).

The windshield wiper and washer lever (see Fig. 3.2b) has the following positions:

I — the windshield wiper and the washer are off;

II — the windshield wiper intermittent mode is on (unstable position);

III — the windshield wiper intermittent mode is on (stable position);

IV — the windshield wiper constant mode (low speed) is on (stable position);

V — the windshield wiper constant mode (high speed) is on (stable position);

VI (pull) — the windshield wiper and washer are on (unstable position);

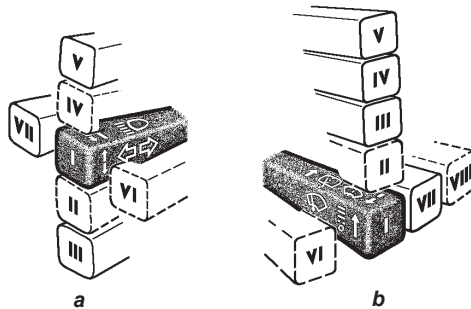

Fig. 3.2. Multi-function under-steering wheel switches:
a — turn signals and headlights beam switch lever;
b — windshield wiper and washer fluid switch lever
(for position names, see the relevant text)

VII — the rear screen wiper is on (stable position) (on hardtop motor vehicles);

VIII — when the lever is pressed, the tail gate screen washer electric motor operates (unstable position), when the lever is released, water supply stops (on hardtop motor vehicles).

4 — horn button;

5 — speedometer. It has two mileage counters: total mileage and trip mileage. The trip mileage counter is set to zero by pushing the reset button;

6 — instrument illumination dimmer switch adjusting the illumination intensity;

7 — instrument panel (Fig. 3.3).

The instrument panel (Fig. 3.3a) by Avtopribor JSC, City of Vladimir:

I — tank fuel level indicator with fuel reserve warning lamp. Each tank is equipped with its own indicator gauge;

II — cooling fluid temperature indicator (on UAZ-315148, with cooling fluid high temperature warning lamp);

III — engine lubrication system oil pressure indicator (on UAZ-315148, with engine oil low pressure warning lamp);

IV — voltmeter indicating voltage in the motor vehicle's electrical system;

The instrument panel (Fig. 3.3b) by the Takosan Company, Turkey:

V — tank fuel level indicator with fuel reserve warning lamp. If there is no signal from the fuel level indicator, the warning lamp flashes. Each tank is equipped with its own indicator gauge;

VI — cooling fluid temperature indicator with cooling fluid high temperature warning lamp. When there is no signal from the engine control unit, the warning lamp flashes ;

VII — engine lubrication system oil pressure indicator with the engine oil low pressure warning lamp. If there is no signal from the oil pressure indicator sensor, the warning lamp flashes;

VIII — voltmeter indicating voltage in the motor vehicle's electrical system;

8 — package of warning lamps (Fig. 3.1). The green and the blue warning lamps inform the driver of normal operation of the system being switched on. The orange lamps warn the driver of necessity to take measures to ensure further normal operation of the motor vehicle. The red lamps warn the driver of necessity to

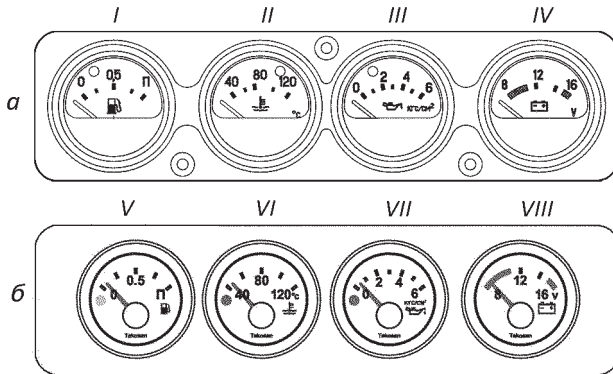

Fig. 3.3. Dashboard:

- a — by Avtopribor JSC, City of Vladimir;
 b — by Takosan Company, Turkey
 (for position names, see the relevant text)

immediately take measures to prevent the emergency operation of the units, and ensure motor vehicle safety;

Do not operate the motor vehicle with any (at least one) red lamp constantly on.

The warning lamp package includes the following:

I — driver safety belt warning lamp (red);

II — UAZ-315148 — glow-plugs on warning lamp (orange). It goes on when the glow-plugs are switched on (when the key in the engine starting switch is switched to position I);

— **UAZ-315195 — glow-plugs on warning lamp (not connected);**

III — the rechargeable battery discharge signalling lamp (red). The lamp switched on with the engine running signals that the rechargeable battery is discharged. The lamp can be on with engine running idle immediately after start. To ensure delivery of current by the generator, you must increase the engine crankshaft rpm, and the lamp should then go off;

IV — UAZ-315148 — fuel filter water sensing lamp (orange);

— **UAZ-315195 — cooling fluid emergency overheat warning lamp (red)*;**

V — UAZ-315148 — the engine control system EDC fault warning lamp (orange). It goes on for testing, when ignition is on, for 2-3 sec, then goes off. **The warning lamp switching on (constant or flashing) indicates malfunctions in the engine control system.**

If the lamp is on constantly, but without significant deterioration of driving performance, you can continue driving to the nearest UAZ PJSC authorized service station for diagnostics.

Do not operate then engine if the lamp flashes. You must stop the motor vehicle and shut the engine off. The motor vehicle may only be operated after the fault is eliminated.

Prolonged operation with the fault indicator switched on can result in failure of the components of the engine control system.

— **UAZ-315195 — warning lamp of high oil pressure in the engine lubrication system (red)*;**

VI — brake system fault warning lamp (red);

VII — parking brake on warning lamp (red);

VIII — warning lamps of turn signals and emergency warning lights switch on (green). It flashes simultaneously with turn signal lamps in motor vehicle lights when the turn signal or emergency warning lights switch is switched on. If there is no lamp signal upon switching of a turn signal or turning an emergency warning lights on, one or several lamps of the turn signal in the lights has failed;

IX — high beam warning lamp (blue). It goes on when high beam is switched on;

X — fault warning lamp of the engine control system OBD components, affecting toxicity of exhaust gases (orange). It goes on when ignition is switched, on and goes off after the engine starts. **The warning lamp turning on indicates faults of the engine components or exhaust system components, affecting toxicity of the exhaust gases. If the warning lamp is on, but without significant deterioration of driving performance, you can continue driving at a low speed to the nearest UAZ PJSC authorized service station for diagnostics.**

Prolonged operation, with the warning lamp switched on, can result in a failure of the components of the engine control system.

9 — electric cigarette lighter. To heat the electric cigarette lighter coil press the insert handle, push it into the housing until fixed, and release the handle. When the coil is heated, the insert automatically returns to its initial position. Do not hold the insert handle by force in the pushed position;

10 — hand-grip;

*This one is not connected on motor vehicles with Takosan Company dashboards

- 11** — switch of the heating system's additional pump (UAZ-315148);
- 12** — emergency warning lights switch;
- 13** — passenger compartment illumination switch;
- 14** — switch of tanks fuel level indicator sensors;
- 15** — heater cover (if the cover is opened, warm air enters the motor vehicle's interior);
- 16** — driver and front passenger leg blower pipes. The air is continuously supplied to the pipes. Air supply is adjusted by dampers installed in the pipes;
- 17** — front axle and speed reduction gearing switch-on lever. (For lever positions, see Fig. 3.4);
- 18** — blind plug;
- 19** — shift lever (for lever positions, see the shift lever knob and Fig. 3.4).

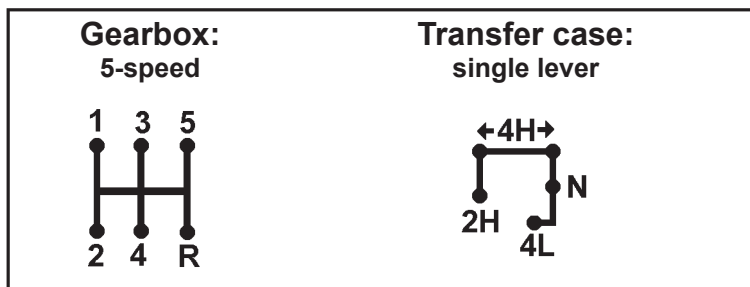

Fig. 3.4. Positions of sticks of the gearbox and the transfer case:
 1-5 — gears; R — reverse gear; 2H — direct gear, front axle disengaged;
 4H — direct gear, front axle engaged (main position — left); N — neutral
 position; 4L — front axle and speed reduction gear engaged.

ATTENTION! *When the speed reduction gear of the transfer case is switched on, the transfer case control lever in the end of stroke shall be independently driven by spring shift slightly to the left (the knob shifts towards the driver).*

To switch the speed reduction gear off, the driver must first move the lever to the right along the motor vehicle motion until it stops, and then move the lever to neutral (straight ahead along the motor vehicle motion).

To prevent destruction of the ends of transfer case gear wheels, engage and disengage direct gear and speed reduction gear only when the motor vehicle is stopped.

20 — parking brake lever. To engage the parking brake, move the lever up; to disengage, push the button on the butt end and move the lever down until it stops;

21 — switch of rear fog lights with built-in illumination lamps and switch-on sensing lamps;

22 — three-position switch of the electric motor heater;

23 — external illumination switch;

24 — accelerator pedal;

25 — brake pedal;

26 — clutch disengagement pedal;

27 — hood latch drive lever;

28+ — radiator grill control handle. When the handle is pulled, the grill shutters close;

29 — ignition switch (UAZ-315148 — engine start switch) (Fig. 3.5). The ignition lock switch is fixed on the steering post with breakaway-head bolts to prevent dismantling of the ignition lock with anti-theft device using standard wrenches. At the Manufacturer's plant, the bolt heads are not broken away to retain possibility to remove the lock from the steering post during the pre-sale period. A consumer must make his/her own decision whether to break the heads away or not.

The ignition lock switch has four positions:

0 — everything is off (stable position);

I — ignition is on (stable position);

II — starter is on (unstable position);

III — standstill (stable position).

The key can only be removed from the lock in position III; at the same time, the locking device mechanism actuates and locks the steering system shaft.

To lock the steering system in standstill, set the key to position III, remove it and turn the steering wheel in any direction until a click is heard, indicating that locking device catch has matched the groove of the steering wheel shaft stop sleeve.

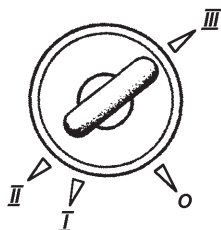

Fig. 3.5. Position of the key in the ignition switch (for position names, see the relevant text)

To unlock the steering system, insert the key into the ignition switch and, swaying the steering wheel right to left and back again, turn the key clockwise to position 0.

To avoid false starter switching on with engine running (key position II), the lock mechanism design includes the interlock enabling the engine re-start only after the key is returned to position 0.

It is prohibited to turn the ignition off and remove the key from the ignition starter switch while the motor vehicle is moving. The engine stop will lead to braking capacity loss, and the steering system shaft is blocked by anti-theft device, if the key is removed and the motor vehicle becomes uncontrollable;

30 — windshield blowing pipes;

31 — air intake lever.

INTERIOR AND EXTERIOR EQUIPMENT OF THE MOTOR VEHICLE

Doors

Safe type door locks and handles. The front door locks and the tail gate lock are locked with the key. The door internal panels are equipped with handles 1 (Fig. 3.6), by means of which the door locks are locked from the interior (handle bottom position). **Locks arrested with handles 1 cannot be unlocked from outside the motor vehicle.** A door can be opened from inside the motor vehicle by turning handle 2 towards you.

To open the sliding windows, push the button 4 (Fig. 3.7) (red) of the locking handle 2, and with handle 1 or locking handle 2, move the corresponding window to the required distance.

To lock the sliding window, match the locking handle 2 with blind sleeve 7 and push button 5 to a fixed position (until a click is heard).

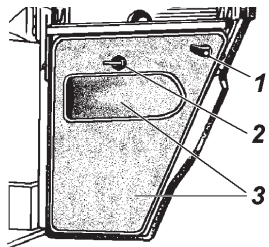

Fig. 3.6. Front door:
1 — lock arresting handle; 2 — door opening handle; 3 — door trim

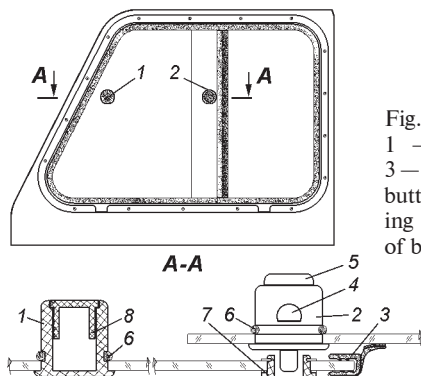

Fig. 3.7. Door prolongation:
 1 — handle; 2 — locking handle;
 3 — prolongation sealing; 4 — unlocking
 button; 5 — locking button; 6 — retain-
 ing ring; 7 — blind sleeve; 8 — handle
 of blind plug

Seats

To change the head rest height, move it vertically:
 - up to extreme position by manual force;
 - down by applying manual force, but with the head rest fastener button 3 pushed in (Fig. 3.8).

The head rest is removed with the head rest fastener pushed.

Longitudinal adjustment of the **front seats** is performed using lever 1 (Fig. 3.8):

- push the lever down;
- move the seat and release the lever.

The seat back tilt is adjusted by turning handle 2.

The rear triple seat (Fig. 3.9) can be spread out to organize a sleeping area, or folded to increase cargo space.

Transformation of seats

Forming of a sleeping area:

- extend the tilting seats into a working position (if available);
- turning handles 1 (Fig. 3.9), tilt the rear triple seat backward until it stops;
- remove the headrests from the front seats, move the seats into extreme front position and, turning the seat back, tilt adjustment knobs, tilt them backwards.

Creation of cargo space:

- unfasten the fastener of the rear triple seat safety belts;
- remove the rear seat headrests (if available);
- turning handles 1 (Fig. 3.9), tilt the rear seat backs forward until they stop;
- unlock the rear seat locks with lock 2 handles (Fig. 3.9);
- tilt the seat forward.

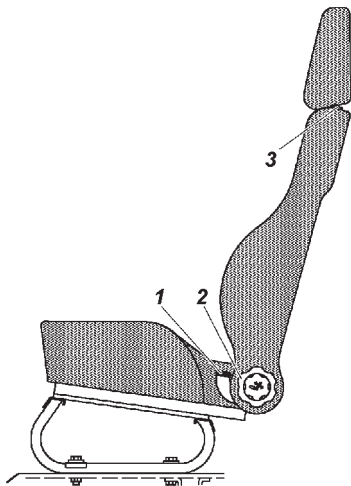

Fig. 3.8. Front seat:

1 — seat longitudinal travel fixing lever; 2 — seat back tilt adjusting knob (lever); 3 — head rest fixing button

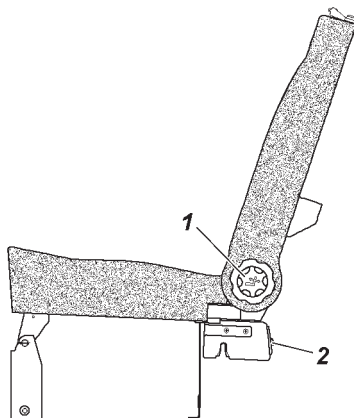

Fig. 3.9. Rear triple seat:

1 — seat back tilt adjusting knob (lever); 2 — lock handle

To return the seat to its initial position, tilt the seat backward until fixed with the lock, lift the backs by turning handles 1 and fasten the quick-disconnect fastener of safety belts.

ATTENTION! *The universal child restraint system, in accordance with Table 3.2, shall be mounted using vehicle safety belts. Infants up to 1.5 years old shall only be transported in the child restraint devices with face turned backwards.*

ATTENTION! *The ISOFIX child restraining systems shall be mounted in accordance with Table 3.1, match of the ISOFIX child restraining systems to installation points in the motor vehicle.*

Table 3.1

Weight category	Size class	Clamp device	ISOFIX position in of a motor vehicle	
			Second row	
			left	right
0 — up to 10 kg	F (Transverse cradle)	ISO/L1	IL	X
	G (Transverse cradle)	ISO/L2	X	IL
	E (Rear-facing seat)	ISO/R1	IL	IL
0+ — up to 13 kg	E (Rear-facing seat)	ISO/R1	IL	IL
	D (Rear-facing seat)	ISO/R2	IL	IL
	C (Rear-facing seat)	ISO/R3	IL	IL
I — 9 — 18 kg	D (Rear-facing seat)	ISO/R2	IL	IL
	C (Rear-facing seat)	ISO/R3	IL	IL
	B (Front-facing seat)	ISO/F2	IUF	IUF
	B1 (Front-facing seat)	ISO/F2X	IUF	IUF
	A (Front-facing seat)	ISO/F3	IUF	IUF

IUF — a place suitable for installation of a "multi-purpose", for the given category, front-facing child seat with ISOFIX fasteners;

IL — a place suitable for installation of a "multi-purpose" child seat with ISOFIX fasteners;

X — ISOFIX position unsuitable for ISOFIX child restraining systems.

Table 3.2.

Weight group	Seats		
	Front seat passenger's	Rear lateral seat	Rear central seat
0 – up to 10 kg (0-9 months)	X*	U*	X
0+ – up to 13 kg (0-2 years)	X	U	X
I – 9-18 kg (9 months – 4 years)	U	U	X
II – III – 15-36 kg (4-12 years)	U	U	X

* Children seat category

U – multi-purpose children seat to place a child either front-facing or rear-facing;

X – place for a seat unsuitable for children of the given weight category

Filler necks of fuel tanks

The body central posts contain hatches with opening lids 1 (Fig. 3.10) to accommodate the filler necks of fuel tanks. In opened and closed positions, the lids are retained with springs. The key-locks 2 can be installed on the hatch lids.

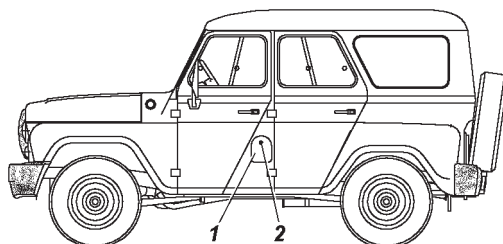

Fig. 3.10. Fuel tank filler location:
1 – hatch cover; 2 – hatch cover lock.

Hood

To open the hood, pull lever 27 (Fig. 3.1), through the formed slot in between the hood and radiator grill, push lever 3 (Fig. 3.11) of the hood opening retainer 2 and lift the hood.

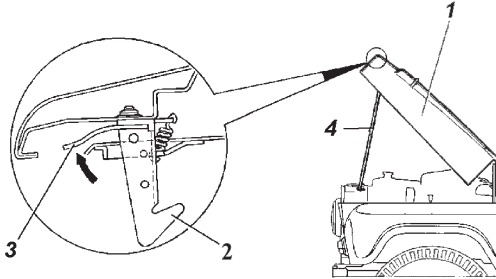

Fig. 3.11. Hood:
1 — hood; 2 — hood opening
arrester; 3 — arrester
lever; 4 — hood back stop.

Safety belts

Remember! The safety belts are efficient means of protecting the motor vehicle driver and passengers against the severe consequences of road traffic accidents. ***The use of safety belts is mandatory!***

The safety belts are designed for individual use by the driver and adult passengers taller than 144 cm and weighing at least 36 kg.

Your motor vehicle is equipped with safety belts (Fig. 3.12) for all seats. The front and the rear seatbelts are three-point with retraction mechanisms. To fasten the belt, pull belt buckle 1 and, without twisting of straps, insert it into lock 2 until a click is heard. To unfasten the belt, push the button on the lock.

Rear seatbelts are equipped with a quick-disconnect fastener, attached to the floor of the interior (see Fig. 3.12 "A"). When folding the seat, unfasten the belts — turn the belt locking buckle 90° and withdraw it from the bracket slot.

Keep the belt straps and buckles clean. If they become dirty, clean them with a mild alkali-free soap solution.

Protect the straps from rubbing against sharp edges.

We recommend protection against exposure to direct sunlight.

To clean buckles from dust, blow them out with compressed air at least once a year.

It is prohibited:

- to twist a strap, to fold it lengthwise, and its excessive slackness;
- to iron straps;

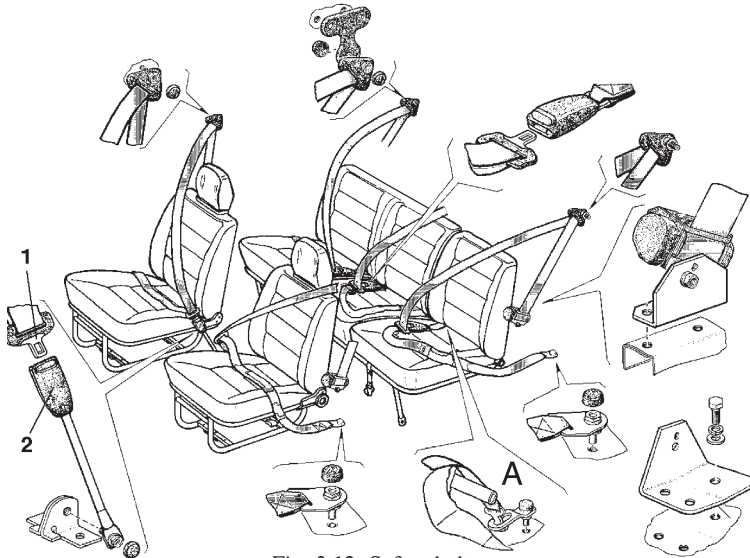

Fig. 3.12. Safety belts:
1 — plate; 2 — latch

- to fasten a child sitting on a passenger's lap;
- for the consumer to make any changes in the safety belt design.

Safety belts must be replaced if they have scuffs or damage, and after a critical load in a road accident.

The safety belts may only be replaced at UAZ PJSC authorized service stations (for addresses of the service stations, see the warranty and service book).

UAZ PJSC shall bear no responsibility for possible injuries, e.g., from road accidents or other damage if safety belt operating rules are violated, or an unauthorized replacement of the safety belts was performed.

Safety belt warning lamp

When ignition is turned on, if the safety belt is unfastened, the safety belt (SB) warning lamp goes on on the dashboard. The warning lamp goes off when the SB buckle is inserted into the retractable SB lock or ignition is switched off.

If the driver's SB is unfastened, for more than 60 seconds or for more than 500 meters of driving or the motor vehicle speed reaches 25 km/h, an additional buzzer goes on.

Safety belt warning lamp fault diagnostics.

The safety belt warning lamp is on when the driver's SB is fastened, then disconnect the retractable SB lock block:

- if the warning lamp goes off, the retractable SB lock is faulty;
- if the warning lamp persists, the wire harness is faulty.

Window wipers and water cleaning pumps

The windshield wiper is electric three-mode.

The rear window wiper is electric single-mode.

To facilitate manual cleaning of the window, the wiper blade arms can be held in a reclined position.

To extend the life of window wipers and their blades, do not allow the operation of blades on dry glass and prevent ingress of fuel and oil onto the rubber of the blade.

Every 18–24 months of operation, and also when necessary, replace the wiper blades or their rubber edges.

The windshield and the tail gate washers are electric and designed to speed up window cleaning.

The windshield washer fluid pump is installed in the washer tank located on the left front wheel splash guard under the hood;

The rear window washer fluid pump is installed in the washer tank located in the niche of the left rear wheel arc.

The removable tanks shall be filled with pure water (in the summer), or with a dedicated windshield wiper anti-freeze (in winter).

Adjust the fluid stream direction by changing the position of spraying nozzle balls with a needle inserted into the balls channel (feed hole).

If the spraying nozzle is clogged, remove it by withdrawing the bracket and disconnecting the tube, and purge with air.

To avoid failure of the washer pumps, check the water level in the tanks, 20 mm above the bottom is the lowest level permitted.

Do not keep the washers switched on for more than 10 seconds.

Interior heating and ventilation

The interior is heated with the air coming from outside through the venting hatch in the front middle part and passing through the heater radiator connected to the engine cooling system.

The interior's ventilation uses the same channels, but with the radiator switched off and with air coming through the sliding window of the door.

When driving along dusty roads, use of the passenger heater fan is recommended. Here, the ventilation hatch cover must be opened (lever 31 (see Fig. 3.1) pulled) and sliding window of the door must be locked.

To ensure the heater's normal operation, the cooling fluid temperature in the engine cooling system must be at least 80°C.

The tap of fluid supply cut-in to the heater radiator is located on the front body panel from the passenger side (under the instrument panel from the passenger side). It is controlled manually pos. 1 (see Fig. 3.13).

To operate the heater, you must turn on the tap of the fluid supply cut-in to the heater radiator, and on UAZ-315148 motor vehicle, also turn on the heating system's additional pump (pos. 11, see Fig. 3.1), and open the ventilation hatch.

Switch 22 (see Fig. 3.1) is used to switch the fan's electric motor on and to select its rpm.

When draining the fluid from the cooling system, the heater tap must be kept open, otherwise the fluid will not drain out of the heater radiator.

Guidelines on UAZ-315148 heating system operational integrity check and recovery

When the cabin heater is inoperative (cold air stream goes from the heater and electric fan, and the heater pump are operative, the engine is warmed up to the temperature of at least 40°C), you must:

Fig. 3.13. Heater tap:
1 — tap lever.

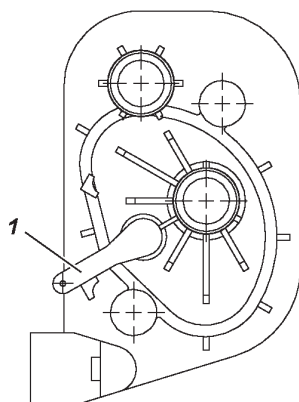

1. Check and, if necessary, bring the cooling fluid level in the engine cooling system to normal (the fluid shall be added to the expansion chamber).

2. The heater tap shall be opened, Fig. 3.12 (the tap lever pos. 1 in extreme bottom position).

3. Turn on (push) the heater pump control button.

4. Open the engine cooler plug.

5. Pinch the hose (see Fig. 9.14) running from the T-joint to the engine cooling/heating system. The hose is located in the rear right part of the engine, along the motor vehicle motion, under the inlet manifold, and shall be pinched using pliers.

6. Bleed the heating system at the engine's medium rpm for 3-4 minutes. If the cooling fluid spills, close the radiator plug.

Note: the Manufacturer shall only guarantee the heating system operational integrity only if the heater pump is in good condition and turned on. When restarting the heater operation in winter season, you might need to repeat the above procedure.

Chapter 4. MOTOR VEHICLE PREPARATION UPON RECEIPT FROM THE MANUFACTURER

The dealer must only put up the motor vehicle for sale upon completion of pre-delivery preparation, as specified in the warranty and service book.

When motor vehicles are delivered to a dealership, preliminary works shall be performed as specified in the sub-section "Daily technical maintenance".

Chapter 5. NEW VEHICLE RUN-IN

The long-term and fail-safe operation of the motor vehicle depends, to a significant extent, on the parts being run-in during the initial operation period.

The motor vehicle run-in shall last for 2,500 km.

During the run-in period, observe the following instructions:

1. Avoid high driving speeds and maximum crankshaft rpm (the engine crankshaft rpm must not exceed 3/4 of the rated value), change gears in due time, in accordance with road and traffic conditions, comparing the crankshaft rpm with the driving speed.

2. During run-in, the motor vehicle load shall not exceed 50 % of the maximum value.

3. Do not drive along rough roads (with deep mud, sand, inclines, etc.).
4. A trailer may not be towed.
5. Do not change the oils in the engine and idler aggregates, filled by the Manufacturer.
6. Monitor the temperature of the brake drums; in case of strong heating, adjust the brakes.
7. Check the temperature of the wheel hubs; in case of strong heating, loosen the bearings.
8. Check tension of the generator belt, cooling system pump belt, power steering pump belt, fan belt and high-pressure fuel pump belt, since during the run-in they are stretched to maximum.
9. Check the condition of all motor vehicle connections. Carefully monitor the pipeline connections, eliminate oil, fuel, and fluid leaks where revealed.
10. The motor vehicle technical maintenance length and schedule during run-in is specified in the warranty and service book.

Chapter 6. ENGINE START AND SHUTDOWN

ENGINE START

General

Prior to starting the engine, check for the presence of cooling fluid in the cooling system, presence of fuel, and oil level in the crankcase.

Move the shift lever to neutral position.

Attention! The ignition switch mechanism has an interlock, allowing you to re-start the engine only after the key is returned to position "0" (Fig. 3.5).

Release the ignition switch key immediately after the engine starts running. The key returns to position "I" automatically (see Fig. 3.5). Warm the engine up to the cooling fluid temperature of at least 60°C.

Duration of continuous starter operation must not exceed 15 seconds. Repeated turning on of the starter is allowed only after a pause of least 1 minute, only three repeated turn ons are allowed. If the engine has not started after this, you must detect and eliminate the malfunction.

Do not start driving the motor vehicle with a cold engine.

It is strictly forbidden to speed up the engine warm-up process through revving up the crankshaft rpm.

ZMZ-40905 engine start

Cold starting at -20°C and above.

ATTENTION! *To ensure reliable engine start at freezing temperatures, the engine oil must have a proper viscosity grade. If the engine oil viscosity grade fails to ensure reliable start at the given freezing ambient temperature, heat up the oil.*

1. Turn the ignition on by turning the key to position "I". Here the fuel priming pump should switch on, its operation can be heard while the engine is off.

2. If the engine is started after a prolonged standstill, we recommend waiting until the fuel priming pump switches off (for about 5 seconds).

3. With the control system operative, the fault warning lamp (on the instrument panel, see Fig. 3.1, pos. 8-X) shall go on and off. If the warning lamp does not go off or flashes during the engine operation, you must detect and eliminate the malfunction (see section "Diagnostics").

ATTENTION! *Engine operation with the warning lamp constantly on or flashing, can result in converter failure.*

4. Press the clutch pedal as far as it can go. Do not press the throttle control pedal when you start the engine.

5. Switch the starter on by turning the key to position "II".

6. When the engine starts, release the key (turn the starter off).

7. Retry starting the engine, if necessary, after a pause of at least 15-20 seconds.

8. Warm the engine up. When the engine is started, its control system will automatically establish the increased idle rpm to warm up the engine and will gradually reduce it to a minimum as the engine warms up.

The warmed up engine cooling fluid temperature shall be at least 70°C.

If the engine does not start, stop the starting procedure, detect and eliminate the fault.

Cold start at temperature below -20°C.

To facilitate cold start at freezing temperatures, the engine must be preheated (by steam, hot air, etc.).

Subsequent operations are the same as those for cold start at -20°C and above.

Hot engine starting.

The sequence of operations is the same as for the cold start at ambient temperature of -20°C and above.

ZMZ-51432 engine starting

ATTENTION! Fuel must correspond with the season of operation.

To ensure reliable engine starting at freezing temperatures, the engine oil must be of proper viscosity grade. If the engine oil viscosity grade fails to ensure a reliable start at the given freezing ambient temperature, heat up the oil.

If necessary, release air from the feed system as described in the section "Engine".

ATTENTION! Do not press the accelerator pedal during engine start procedure!

Do not start driving immediately after a cold start. After the engine starts, let it run for 1–2 minutes at idle minimum rpm in order to restore the turbocharger and engine systems to service condition. After this, the engine is ready for operation.

Start driving a cold engine with a moderate load. The optimal engine operating conditions are ensured with the cooling fluid temperature of plus 60–110°C.

Engine starting at cooling fluid temperature below +23°C.

Turn the key in the start switch to position "I". Wait until the glow-plugs cut-in warning lamp goes off. Disengage the clutch and engage the starter (position "II"). Keep the starter engaged until the engine starts, but no longer than 15 seconds.

Retry starting after a pause of at least 1 minute.

If the engine fails to start or stalls, return the key to position "0". Then turn the key to position "I", wait until the glow-plugs cut-in warning lamp goes off, and restart. If the engine fails to start after three attempts, detect and eliminate the fault.

Engine starting at cooling fluid temperature above +23°C.

The sequence of operations is the same as that for engine starting at cooling fluid temperature below +23°C, where the glow-plugs cut-in warning lamp does not go on repeatedly, since the plugs do not cut in.

ENGINE SHUTDOWN

Prior to engine shutdown, let it run for 1-2 minutes (UAZ-315148 — for 3-5 minutes) at low crankshaft rpm.

To turn off the engine, turn the key in the ignition switch to position "0".

ATTENTION! *We do not recommend to let the engine of UAZ-315148 motor vehicles run at idle minimum rpm for more than 10 minutes, since due to negative pressure being created by the*

cylinder-piston group, the air pressure inside the compressor housing is set to below atmospheric pressure. Part of a lubricant oil from the TCR bearings housing through the compressor wheel labyrinth seal, enters the engine inlet system, resulting in the increased smoking of engine.

Chapter 7. VEHICLE DRIVING IN DIFFERENT ROAD, WEATHER AND CLIMATIC CONDITIONS

The motor vehicle operation and service life depend, to a large extent, on specifics of driving. Driving correctly, you will ensure the motor vehicle motion with high average speed and low fuel consumption. **We recommend to start off at level stretches of hard-surface roads or downward in the second gear. In all other cases, start driving in the first gear. Change gears and engage the front axle when the clutch is disengaged.**

To avoid jerks in the power train, do not allow the engine operation at reduced rpm while driving, for this, change the gears in due time.

Change the gears with smooth pressing onto the lever and without jerks. If it is not possible to engage the required gear prior to starting off, slightly release the clutch pedal and then disengage the clutch again and engage the gear.

The speed synchronizers in the gear box allow changing gears without double disengagement of the clutch. However, to speed up the gear changing process, and to extend the service life of speed synchronizers, we recommend applying double disengagement of the clutch with throttling, when changing from higher to lower gear.

The reverse gear in the gearbox shall only be engaged after the motor vehicle comes to a complete stop. Do not rest your foot on the clutch pedal while driving because this leads to partial clutch disengagement and disk slippage. On a slippery road, drive steadily at a low speed.

Release the throttle pedal completely when braking with the engine.

Brake the vehicle smoothly with gradual increase of pressure on the brake pedal. Any braking increases the wear of tires and fuel consumption. Avoid slipping of the wheels when braking as this extends the braking path and wear of the tires. Furthermore,

sharp and hard braking on a slippery road can result in the motor vehicle skidding.

When driving the motor vehicle off the road (on sand, mud, snow, etc.), on slippery roads, steep climbs (above 15°) and on other rough road sections, do not overload the engine. In such conditions, engage the front axle, and prior to motion, under extremely severe conditions, also engage the speed reduction gear in the transfer case. Engage the front axle, while the motor vehicle is moving, and only engage the speed reduction gear in the transfer case, after the motor vehicle comes to a complete stop.

Steep climbs and downgrades. When driving along the road with steep climbs and downgrades, the driver must pay close attention and act promptly. Determine the uphill gradient in advance and engage the gear in the gearbox, which will ensure the required rim pull to prevent changing of gears in climbing. Steep climbs shall be passed at the speed reduction gear in the transfer case and in the first gear in the gearbox. Climbs shall be passed without stops and, if possible, without turns. Short climbs with convenient approach and comparatively even road surface shall be passed in acceleration without engagement of the speed reduction gear in the transfer case, in the second or third gear in the gearbox, depending on the uphill gradient. If the climb cannot be passed for any reasons, take all the precautions and go down slowly, having engaged the reverse gear. Go down gradually, not allowing the motor vehicle to accelerate and not releasing the clutch. For steep downgrades, involve the measures ensuring safety when driving down. For a long downgrade (over 50 m), estimate its downhill gradient in advance and engage in the gearbox and the transfer case the gears, in which the motor vehicle would pass the climb of a similar gradient. Such downgrades shall be passed using braking with the engine.

ATTENTION! *Please remember that in case of frequent pumping of the brake pedal (after the pedal is released, it is pressed again immediately), the vacuum pump may not have enough time to create the required negative pressure, causing the braking capacity to decrease, and it will be necessary to apply an increased force to the brake pedal.*

It is prohibited to pass a downgrade with a disengaged gear in the gearbox or the transfer case, or with the clutch disengaged.

Prevent high rpm of the crankshaft when driving down, apply brakes from time to time to reduce the motor vehicle's speed.

Trenches, roadside ditches and muddy areas shall be passed at a low speed with the front axle engaged, in the direction perpendicular to the slope and with due account of the motor vehicle size, determining its off-road capacity. Do not cross the obstacles at once if a frontal collision with the wheels is probable.

When passing trenches and muddy area, take due account for the motor vehicle cross-axling and sticking due to wheel slippage.

Driving along muddy country roads and earth graded roads on clayey and black-earth grounds. On clayey and black-earth grounds, after heavy rains, the moving motor vehicle can slide from the road. For this reason, take special care in selection of the driving direction. When driving, select comparatively leveled sections of the path and use, whenever possible, the laid rut, thus preventing the motor vehicle from skidding sideways. It can be extremely difficult to drive the motor vehicle along excessively wet earth graded roads, having steep grades and deep ditches. On such roads, drive carefully on the crest and at a low speed.

Marshland shall be passed along a straight line without sharp turns and stops. Start off smoothly and without jerks. Move with the front axle and speed reduction gear in the transfer case, engaged using the gear in the gearbox, which would provide the required drive rim pull without slipping. To prevent slipping of the wheels and losing of adhesion with the turf, turn smoothly with large radius and do not reduce the motor vehicle speed. Do not drive along the track made by the vehicle ahead.

When passing sandy sections, drive smoothly without jerks and stops. Turns shall be smooth and with a large radius. In driving, engage the highest feasible gears with the front axle engaged, pass the sand drifts and short sand climbs at once. Prevent the wheels from slipping. Estimate the road situation in advance and engage the gearbox gear, which will ensure the required rim pull.

Fording point shall be passed with great care. The motor vehicle is capable of low-speed passing a ford up to 500 mm deep with solid bottom. Prior to passing a ford, check thoroughly the bottom condition, make sure it contains no deep pits, big stones, mud flats, and select and check the locations of the motor vehicle entering and leaving the water.

Pass a fording point carefully, without a wake in front of the motor vehicle, in the first or second gear of the gearbox with the front axle and speed reduction gear in the transfer case engaged.

Avoid maneuvering and sharp turns.

After fording, as soon as possible, but not later than on the same day, check oil condition in all the units. If you detect water in the oil, replace the oil in the unit. Water presence in the oil shall be detected by a change in the oil color. Lubricate all grease nozzles of the chassis until fresh lubrication appears. Each time the motor vehicle leaves a fording point, several times, partly disengage the clutch and partly apply the brakes in order to dry out the clutch facings and the brake shoe linings.

If the motor vehicle engine stops while fording, try two-three times to restart the engine using the starter. If the engine fails to start, the motor vehicle must be immediately removed from the water by any possible means. If some water penetrated into the motor vehicle units, it is not recommended to drive the vehicle after the motor vehicle is removed from the water. Tow the motor vehicle to a place where technical maintenance is feasible.

The vehicle can move along virgin snow down up to 350 mm high. Make turns in the manner same as for moving on marshland. When driving along grainy snow, apply the driving rules that are stipulated for driving along a sand surface.

Chapter 8. VEHICLE TOWING

For towing purposes, the motor vehicle is equipped with tow hooks and lugs (Fig. 8.1).

The motor vehicle must be towed smoothly without jerks.

A trailer may only be towed if the ball-type tow unit is available.

Attention! towing of the motor vehicle by the ball-type tow unit is strictly forbidden!

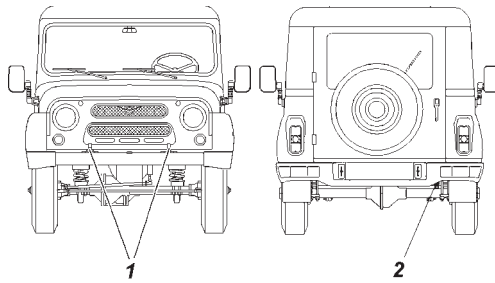

Fig. 8.1. Towing hooks and tow unit:
1 — towing hooks; 2 — rear lug

Chapter 9. VEHICLE MAINTENANCE

The vehicle maintenance volume and frequency is given in the warranty and service book.

The present section describes the techniques of vehicle care and adjustment of its components, and also works to be performed on a regular basis in between the maintenance operations provided for by the warranty and service book cards.

DAILY MAINTENANCE

1. Check visually the vehicle integrity, body condition, windows, rear-view mirrors, appearance, registration plates, painting, door locks, wheels, and tires. Eliminate the revealed defects.

Inspect visually the parking space to make sure no leaks of fuel, oil, cooling and braking fluids are present. Eliminate the revealed defects.

Check and replenish to the standard, the amount of cooling fluid, oil in the crankcase, braking fluid and fuel.

2. Check functioning of steering system, brake systems, illumination devices, light and sound alarm and window wiper. Eliminate the revealed defects.

3. Fill the windshield washer fluid tank. Water is allowed for use in warm season.

4. If the vehicle was operated in a very dusty environment, or crossed fording sites and stretches of unpaved roads covered with mud, check contamination of the engine air filter cartridge, and clean or replace it, if necessary.

5. After a trip, wash the vehicle if operated on dirty or dusty roads.

6. At least once a week, check and bring into compliance the tire pressure.

VEHICLE MAINTENANCE EVERY 500 KM

On a new vehicle, after the first 500 km are traveled, tighten the steering mechanism case mounting arrangement, wheel retaining nuts, tie rod retaining nuts, lateral bars, and spring center clamps.

SEASONAL MAINTENANCE

Seasonal service shall be carried out twice a year, in spring and in autumn, and if possible, shall be done at the same time with routine maintenance according to the warranty and service book cards.

Prior to summer operation

1. Remove the oil pump lid and check the condition of the oil pump drive gear wheels (UAZ-315195).
2. Check the operation of the window wiper and washer. Eliminate the defects.
3. Replace oils in components with summer (all-season) grade oils specified in the lubrication schedule.

Prior to winter operation

1. Check density of fluid in the engine cooling system and bring to the required value (1,075–1,085 g/cm³ at 20°C), if necessary.
2. If water is poured into the windshield washer tank, drain the water. Pour in the low freezing point windshield washer fluid.
3. Check the operation of the interior heating and ventilation system. Eliminate the defects.
4. Prior to winter operation (or at 30,000 km), flush the fuel tanks.
5. Replace oils in the aggregates with winter grade oils specified in the lubrication schedule.

ZMZ-40905 ENGINE

Engine suspension

During operation, check tightening of threaded joints of the front and the rear engine suspensions (see Appendix 2) and condition of the mounts. No delamination and breakage of the engine mounts is allowed.

Engine cylinder head

When the engine is operated, the cylinder head fastening bolts need no tightening. If necessary, only tighten the bolts on a cold engine. To ensure uniform and proper bearing of the cylinder head to the gasket, tighten the bolts as per the sequence shown

in Fig. 9.1 in two steps. Tighten the bolts uniformly, using a torque wrench (see Appendix 2). The bolts fastening the cylinder head on the chain cover (11, 12) shall be tightened individually after the bolts 1...10 are tightened.

In case of increased oil consumption, due to burnout loss, pinking and surface ignition, remove the cylinder head and clean surface of the combustion chambers, valve discs and piston top off soot deposition.

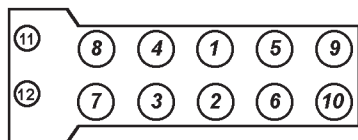

Fig. 9.1. Sequence of tightening cylinder head fastening bolts.

Engine gas distribution mechanism

The camshafts have chain double-stage drive. The chains are pulled by hydraulic tensioners.

ATTENTION! *Do not take the hydraulic tensioner out of the chain cover to prevent disengagement of the piston with the casing caused by the compressed spring.*

The valves are driven from the camshafts directly via the hydraulic pushers. Where the hydraulic pushers are being used, no clearance adjustment is required.

Engine lubrication system

If there is a fault in the lubrication system, the operation of the engine must be stopped immediately.

For oil cooling, the lubrication system comprises the oil radiator connecting into the cooling process automatically, using the thermal valve.

Monitor the oil level in the crankcase on a regular basis and refill when necessary. Check prior to the starting engine. If the oil level is to be checked after the engine stop, wait for at least 15 minutes to let the oil drain to the crankcase. The vehicle must rest on a smooth level pad. The oil level shall be between the marks "O" and "P" of the oil level indicator 11 (Fig. 9.2). For frequent cross-country trips, maintain the oil level near the mark "P" with no surpassing of it.

When changing the engine oil, replace the oil filter. Drain the used oil from the engine crankcase immediately after a trip, while it is still hot. In this case, the oil pours out quickly and completely.

Remove the oil filter 13 (see Fig. 9.3) by turning it counter-clockwise. When installing a new filter, make sure the rubber O-ring is in proper condition and lubricate it with engine oil, turn the filter until the O-ring touches the plane on the engine block and then tighten the filter another 3/4 of a turn. Make sure no oil leak exists.

Pour the fresh oil up to the upper mark on the oil level indicator and start the engine.

After the oil emergency low pressure alarm switches off, stop the engine, and in 15 minutes check the oil level. If necessary, add more oil.

ATTENTION! *The Manufacturer installed a smaller oil filter onto the ZMZ-40905 engine, which must be replaced during the first maintenance (when the first 2,500km are covered) with one of the following*

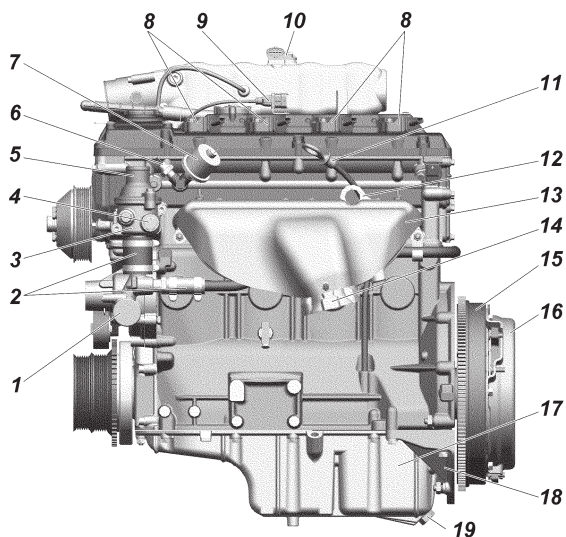

Fig. 9.2. ZMZ-40905 engine. Left-side elevation (the fan and the fan drive coupling are removed for clarity): 1 — pipe of the cooling fluid supply from the radiator to the water pump; 2 — connecting hoses; 3 — temperature control valve housing; 4 — control system cooling fluid temperature sensor; 5 — pipe of cooling fluid removal from the temperature control valve to the radiator; 6+ — emergency oil pressure alarm sensor; 7 — oil pressure indicator sensor; 8 — ignition coils; 9 — crankshaft position sensor connector; 10 — absolute pressure and temperature sensor; 11 — oil level indicator; 12 — engine lift rear bracket; 13 — exhaust manifold screen; 14 — exhaust manifold; 15 — flywheel; 16 — clutch; 17 — oil casing; 18 — clutch casing stiffener; 19 — oil drain plug

filters: 2101S-1012005-NK-2, 2105S-1012005-NK-2 manufactured by the KOLAN Company, or 409.1012005, 406.1012005-02 manufactured by the BIG-filter LLC.

With warm engine and non-faulty lubrication system in the idle mode, the oil emergency pressure indication lamp may remain on, but it must gradually dim as the crankshaft rotation speed increases.

Please remember, the engine always contains trapped oil. Pour the oil in portions, bringing the oil level at the indicator to the upper mark "P". The volume between the marks "O" and "P" holds about 1 liter of oil. Oil level above the "P" mark is not allowed.

Use only the recommended oils.

The engine oils of different grades and different manufacturers may not be mixed! If the engine oil of another grade or

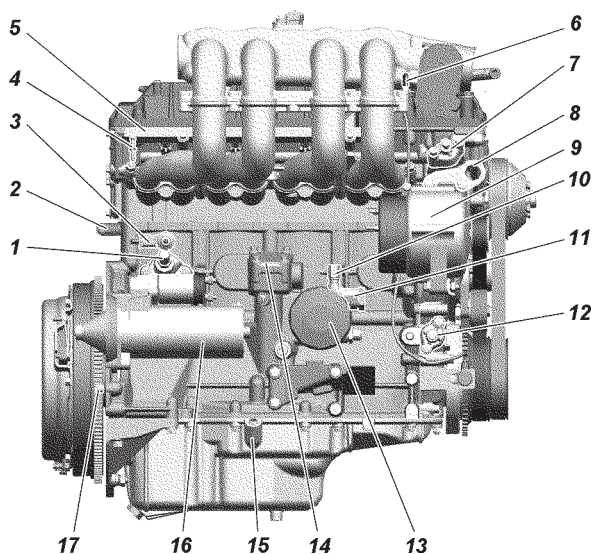

Fig. 9.3. ZMZ-40905 engine. Right-side elevation (the fan and the fan drive coupling are removed for clarity): 1 — pipe of cooling fluid removal to the heater; 2 — tube of cooling fluid intake from the heater; 3 — knock sensor; 4 — fuel line nozzle; 5 — fuel rail with orifices; 6 — IMTMS "-" wire fastening pin; 7 — upper hydraulic tensioner lid; 8 — engine lift front bracket; 9 — generator; 10 — nozzle of oil removal to oil radiator; 11 — thermal valve; 12 — lower hydraulic tensioner lid; 13 — oil filter; 14 — oil pump drive cap; 15 — connection location for nozzle of oil drain out of the radiator; 16 — starter; 17 — gear box setting pin

manufacturer is to be poured, make sure you have flushed the lubrication system with washing oil. The washing oil shall be selected in accordance with the recommendations of the manufacturer of the new oil to be poured into the engine.

It is recommended to flush the engine lubrication system every two oil changes. To do this, drain the used oil, pour in the special detergent oil 3-5 mm above the mark "O" at the oil level indicator and let the engine run for 10 minutes. Then, drain the detergent oil, replace the oil filter and pour in the fresh oil. If no detergent oil is available, clean engine oil can be used for flushing.

Engine crankcase ventilation system

During the maintenance of the engine crankcase ventilation system, remove valve cap 4 (Fig. 9.4), ventilation hoses and tubes, vacuum valve cap 3, the valve membrane and spring, and clean the removed parts. Clean the holes of valve cap ventilation necks, holes 7 of separated oil drain, calibration orifice 8 in the vacuum valve case, and venting holes in the vacuum valve cap. The oil baffle 5 shall be flushed while remaining mounted on the valve cap. Check the membrane for damage and breakage. When re-assembling, ensure hermetic-tightness of connections.

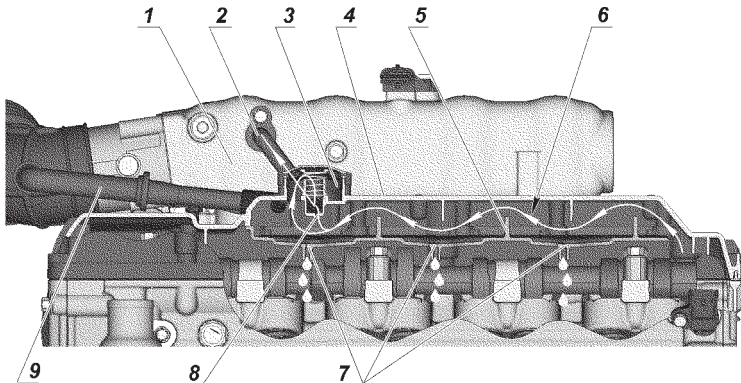

Fig. 9.4. The engine crankcase ventilation pattern:

1 — receiver; 2 — venting tube connects the vacuum valve with the receiver; 3 — vacuum valve; 4 — valve cap; 5 — oil baffle; 6 — crankcase stream of gases; 7 — holes for drain of oil separated from crankcase gases; 8 — hole in the vacuum valve; 9 — tube of air removal from the inlet system to the engine with back-pressure valve

ATTENTION! *The engine may not be operated if the crankcase ventilation system is not tightly sealed and with opened oil filler. This results in an increased escape of oil with crankcase gases, and contamination of the environment. To prevent the crankcase ventilation system from de-pressurization, you must close the oil filler cap tightly, as far as it can go, and install the oil level indicator against stop.*

Engine cooling system (Fig. 9.5)

ATTENTION! *The cooling fluid is toxic. Store the fluid in a tightly closed container. The following rules must be observed during work with the cooling fluid:*

- avoid any operations resulting in ingress of the fluid into your mouth;
- in case of skin contact, do not let the fluid dry on the skin, and immediately wash it away with warm water and soap;
- wash away any spilled fluid with water and ventilate the room;
- take off any clothing contaminated with the fluid, dry it outdoors, and then wash it.

Take care when opening the engine radiator plug to avoid scalding.

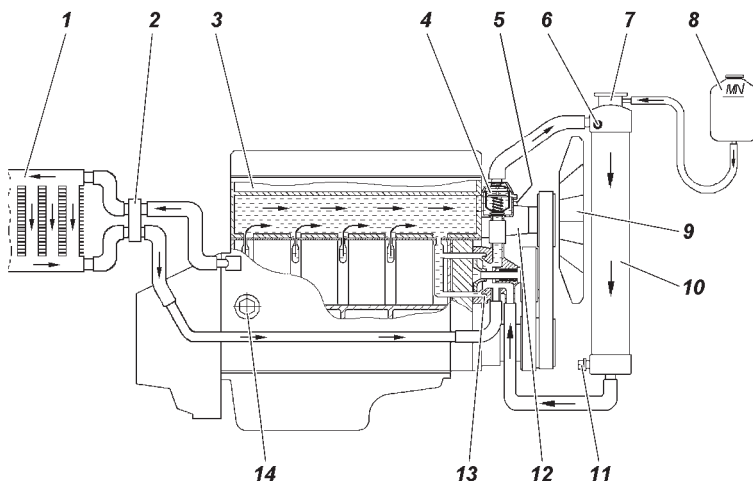

Fig. 9.5. The engine cooling system pattern:

1 — interior heater radiator; 2 — passenger compartment heater tap; 3 — engine; 4 — temperature control valve; 5 — cooling fluid temperature sensor at the control unit; 6+ — cooling fluid overheating alarm sensor; 7 — radiator filler; 8 — expansion chamber; 9 — fan; 10 — cooling system radiator; 11 — drain plug; 12 — fan drive; 13 — pump; 14 — drain plug on the cylinder block

For cooling, the following fluid is used: low freezing point fluid TOSOL-A40M, OZh-40 "Lena" or OZh-40 "TOSOL-TS".

When the ambient air temperature is below -40°C , use the low freezing point fluid TOSOL-A65M, OZh-65 "Lena" or OZh-65 "TOSOL-TS".

The cooling fluid operating temperature shall be within $80-110^{\circ}\text{C}$. Short-time (maximum of 5 minutes) engine run is allowed at cooling fluid temperature increase to 120°C .

When the cooling fluid overheat warning lamp turns on, you must immediately identify and eliminate the cause of overheating.

From time to time, check the cooling fluid level in the expansion chamber. The fluid level must be 3-4 cm above the mark "min". Since the cooling fluid has high thermal expansion coefficient and the cooling fluid level in the expansion chamber varies significantly, depending on the temperature, check the level when the system temperature is $+15-20^{\circ}\text{C}$.

When the cooling fluid in the expansion chamber decreased within a short period or after a moderate travel (up to 500 km), check the cooling system hermetic-tightness and after elimination of leaks, add the same cooling fluid into the radiator or the expansion chamber.

In exceptional cases, e.g., major leak of cooling fluid, short-time filling with pure fresh water into the cooling system is allowed. Sea water may not be used, nor alkali to soften the water, since it corrodes the engine's aluminum parts. Prior to use, filter the water using the materials at hand. As soon as possible, drain the water completely, flush the cooling system, and fill it with the cooling fluid specified in Appendix 3.

ATTENTION! *The Manufacturer shall not bear responsibility for the breakdown of parts caused by freezing of water in the cooling system.*

The cooling system shall be flushed as follows:

- fill the system with pure water, start the engine, let it work until warm, stop the engine and drain the water;
- repeat the above operation.

Due to presence of air in the interior heater, the temperature booster and connection hoses, the cooling system shall be charged as per the following procedure:

- close the cooling fluid drain plugs;
- switch the interior heater valve actuating lever into position "open";

- fill the radiator with the cooling fluid to the level of 10-15 mm below the throat, and the expansion chamber to the level of 3-4 cm above the mark "min";
- start the engine, add the cooling fluid to the radiator upper tank when its level decreases, and close the radiator plug;
- stop the engine, let it cool down, raise the cooling fluid level in the expansion chamber to the standard, and close the expansion chamber plug;
- run 2-3 cycles of the engine warm-up — cool-down, and again raise the cooling fluid level in the expansion chamber to the standard.

The fluid shall be drained from the engine cooling system through two holes closed with plugs 11 and 14 (Fig. 9.5). During draining, the interior heater valve actuating lever 2 must be switched to the position "open".

The steering booster fan and pump drive belt 14 (Fig. 9.6) are tensioned by the pump 13 displacement, for which the following must be done: loosen bolts 11, adjust the belt tension using adjustment bolt 12, while moving the pump along the bracket, and tighten bolts 11.

The cooling system and engine generator drive belt 3 (Fig. 9.6) tension is ensured by the automatic belt tensioner. No belt tension adjustment is required during operation.

To check the automatic tensioner condition, check smoothness of motion of the lever with the tensioner roller from one extreme position to another, with the belt removed. In case of jamming, replace the belt tensioner mechanism.

The fan drive clutch. If the clutch no longer engages or engages incompletely, the engine can overheat. The clutch condition must be checked at UAZ Service Stations possessing the dedicated equipment.

Keep the external surface of the clutch clean.

During the operation, you must monitor the distance between the fan blades and the radiator upper tank, as well as the distance between the clutch and the radiator core, the distance shall be equal to at least 15 mm.

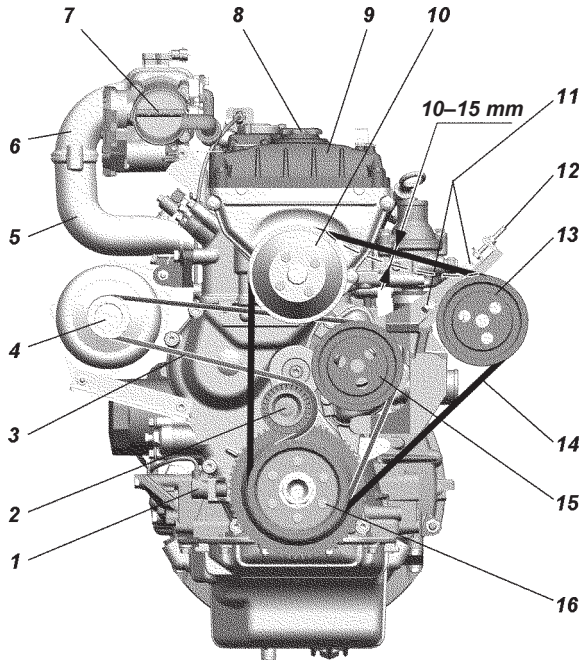

Fig. 9.6. Drive belt tension of aggregates:

1 — timing sensor; 2 — automatic tensioner; 3 — generator and water pump drive belt; 4 — generator pulley; 5 — inlet pipe; 6 — receiver; 7 — throttle unit with throttle gate position sensor; 8 — oil filler cap; 9 — valve cap; 10 — fan pulley; 11 — fastening bolts; 12 — adjustment bolt; 13 — power steering pump pulley; 14 — power steering fan and pump drive belt; 15 — water pump pulley; 16 — crankshaft damping pulley

Exhaust system

ATTENTION! *The converter operating temperature shall be 400-800°C. The vehicle may not be operated if no protective screen is installed on the converter. When the vehicle is in motion and in standstill, ensure that the exhaust system has no contact with flammable materials (e.g., dry grass).*

Leak of exhaust gas in the exhaust system connections, fitted with gaskets, is not allowed and shall be eliminated when it first occurs. Stuck nuts shall be tightened (see Appendix 2) with preliminary wetting of thread connections with special liquids or kerosene.

When the fuel system or the ignition system is faulty, a great quantity of unburnt hydrocarbons ingress into the converter, thus

the temperature in the converter can rise above the admissible limit and the converter will fail. So, special attention must be paid to the operation of the fuel system and the ignition system. Three-cylinder operation of the engine is prohibited even for a short period of time.

Fuel injection system with microprocessor-controlled fuel supply and ignition (Fig. 9.7)

To accomplish the Integrated Microprocessor-based Engine Control System (IMECS) control unit self-diagnostics mode, and to connect the engine control system automated external diagnostics and programming devices, the data link connector is installed under the hood on the front body panel (above the engine).

The main switch power circuit, running from the battery, is protected against ground short circuits with 10 A harness fuse. At the same time, IMECS ignition circuit is protected against

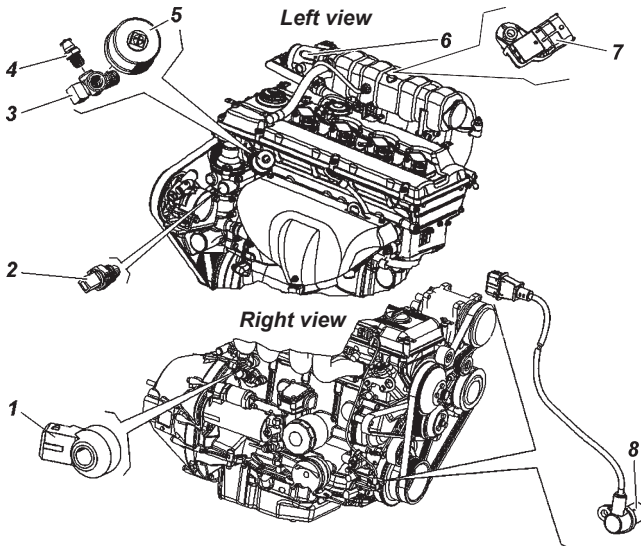

Fig. 9.7. Sensors layout on the engine:

1 — knock sensor; 2 — engine temperature situation (cooling fluid temperature) sensor; 3+ — nozzle; 4+ — oil emergency pressure sensor; 5 — oil pressure indicator sensor; 6 — throttle block with throttle gate position sensor; 7 — absolute pressure and temperature sensor; 8 — crankshaft position sensor (timing sensor)

ground short circuits with 10 A harness fuse. The fuses are installed into the fuse holder kits, which are fastened as follows:

- 20 A — to the main relay;
- 10 A — to the electric fuel pump relay.

Precautions

1. Prior to dismantling and installation of any components or wires of the control system, disconnect the rechargeable battery ground wire.

2. The engine may not be started if the rechargeable battery is connected unreliably.

3. The rechargeable battery may not be disconnected from the vehicle's electrical network while the engine is running.

4. If being charged from the external source, the rechargeable battery must be disconnected from the vehicle's electrical network.

5. The control unit may not be exposed to temperatures above 80°C, e.g., in an oven dryer.

6. Prior to arc welding operations, disconnect the battery wire and the control unit connector.

7. To prevent rusting of pins during vapor cleaning, do not direct the nozzle towards system components.

8. The electronic components of the control systems are designed for very low voltage and are vulnerable to electrostatic discharges.

9. The fuel system, at the section from the fuel priming pump to the fuel pressure controller on the running engine, is pressurized to 3.8 kgf/cm².

To prevent leaking of fuel, check thoroughly the hermetic-tightness of the pipeline joints. The check shall be carried out with sufficient lighting and the engine running idle.

The threaded joints leaks shall be eliminated through tightening of nuts and nozzles by a wrench with moderate force ensuring hermetic-tightness.

The fuel line joints may not be loosened with the engine running or immediately after it stops.

10. To avoid fuel priming pump failure, it may not be switched on dry, when there is no fuel in the right-side tank.

11. The engine, in which low-voltage wires to the ignition coils are installed improperly, may not be started. The branch of wires to the ignition coils must be connected in series, starting from the first cylinder.

Fuel system

ATTENTION! Motor gasoline and its vapors are toxic and flammable. Observe the following rules:

- observe the fire safety rules;
- avoid any operations resulting in the ingress of the gasoline into your mouth;
- in case of skin contact, do not let the gasoline dry on the skin and immediately wash it away with warm water and soap;
- cover the spilled gasoline with sand or chips, brush off and dispose of, and ventilate the room;
- take off any clothing contaminated with gasoline, dry it outdoors, and then wash it.

ATTENTION! Only use the recommended unleaded gasoline (lead contained in the leaded gasoline causes failure of the exhaust gas oxygen sensors and of the converter).

The fuel module is installed in the right-side tank. As the fuel is consumed, the right-side tank is refilled automatically from the left-side tank.

The plugs of the fuel tanks filling pipes necks are blind and ensure tight packing.

The following is recommended, due to the specified features of the fuel system design:

- when closing the tank filler necks, make sure the plugs are in good condition, the sealing gasket is present and undamaged, and ensure tight closing of the plugs through application of
 - for partial fuelling of the vehicle, start from the right-side tank;
 - monitor the fuel consumption with due account for variation of the fuel amount in both tanks.

ATTENTION! Use of inferior quality fuel can result in the failure of the converter.

The final fuel filter 18 (Fig. 9.8) is made in the form of a disposable solid element filter. When clogged, it must be replaced.

Fuel tanks 24, 25 (Fig. 9.8). Maintenance of the fuel tanks include periodic flushing of the fuel module filter (the right-side tank) and flushing of the tanks themselves.

Check from time to time the reliability of the tanks fastening and, if necessary, tighten the fastening bolts.

Fuel tanks must be dismantled from the vehicle in order to flush them.

Prior to dismantling of the tanks from the vehicle, do the following:

- disconnect the rechargeable battery;
- drain the fuel by unscrewing the plugs on the tanks bottoms;
- open the hatch in the body's floor above fuel module 3, turn off the separator 27 fastening bolts (Fig. 9.8), remove it and disconnect hoses from it;
- disconnect the block from the fuel module and isolate them;
- disconnect the fuel lines tubes and hoses.

Then unscrew the bolts of the fuel tanks bands, bend the bands down, so they do not obstruct the tank lowering, and remove the tank.

The tank shall be re-installed in reverse order.

The fuel module 3 (Fig. 9.8) is submersible and comprises the fuel priming pump, the strainer, the jet pump, the pressure controller, and the fuel tank level gage.

From time to time, check and clean the pins of the fuel pump connection to the vehicle's electrical network.

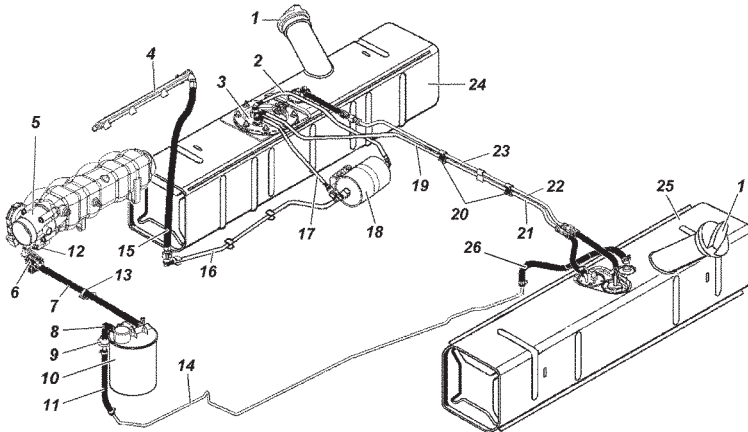

Fig. 9.8. The engine fuel system pattern:

- 1 — fuel tank plug; 2 — tube from the fuel priming pump to the final fuel filter;
- 3 — fuel module; 4 — fuel rail; 5 — throttling device; 6 — absorber purge valve;
- 7, 8, 11, 12, 26 — vapor removal hoses; 9 — gasoline tank valve; 10 — absorber;
- 13 — fastening bracket of wire harnesses; 14 — steam tube; 15 — fuel tube;
- 16 — fuel feed tube; 17 — tube of fuel drain from the final fuel filter to the submersible module; 18 — final fuel filter; 19 — tube of fuel feed to the right-side tank; 20 — plastic duplex bracket; 21 — tube of fuel feed from the left-side tank; 22 — vapor removal tube from the left-side tank; 23 — vapor removal tube from the right-side tank; 24 — right-side fuel tank; 25 — left-side fuel tank

Pay special attention to reliability of the ground connection.

It is not recommended to operate the vehicle, if there is less than 5 liters of fuel in the right-side fuel tank.

When traveling over steep climbs, there must be at least 20 liters of fuel in the right-side tank.

The fuel module filter shall be flushed when the tank is not removed from the vehicle, and, furthermore, the fuel module must be withdrawn from the fuel tank through the hatch in the body's floor.

Clogging of the fuel priming pump strainer, final fuel filter, presence of dirt and mechanical admixtures in a fuel tank manifest first of all in deterioration of the pumping of the fuel from the left-side tank into the right-side one, unstable engine operation at high loads, and degradation of the vehicle performance. If such signs arise, seek help from a service station in order to prevent fuel priming pump failure.

Note. At ambient air temperature of below 0°C, the clogging signs can be due to water presence and freezing in the fuel system. If water was detected in the fuel, drain the fuel and flush the fuel tanks with pure gasoline, and replace the final fuel filter.

Leak in connections shall be eliminated by tightening worm drive clamps (see Appendix 2) or replacing faulty components. The fuel tubes shall be installed until a "click" of the quick coupler's locking spring.

Upon completion of any fuel system maintenance operations, related to tightening of connections, removal or replacement of parts and assemblies, the system hermetic-tightness must be checked as follows:

- make sure the filler ports plugs are securely tightened;
 - tighten the clamps and quick removable connections until hermetic-tightness is ensured;
 - fuel tubes shall be installed until "click" of the quick coupler's locking spring;
 - start the engine running idle and check the system visually.
- Fuel leaks or the fuel system components wetting may not be allowed.

In the course of vehicle operation, pay attention to the following:

- a strong smell of gasoline within the vehicle's salon, engine compartment in locations of passage of fuel and steam hoses and tubes, if this occurs — check the hermetic-tightness of joints, condition of the adsorption container (absence of cracks and damage, serviceability of the adsorption container's purge valve);

- the operation of the evaporative emissions system (the adsorption container and the fuel tank valve). When faulty, these components cause a malfunction in the operation of the fuel system. Replace the failed components;

- overcompression and damage of the fuel and steam hoses; replace the damaged and unsealed tubes and hoses.

Accelerator pedal drive. The vehicle has an accelerator pedal electronic module, for which no adjustment is required.

Air filter. The vehicle has an air filter (Fig. 9.9) with a replaceable cardboard filtering cartridge.

Replace the filtering cartridge 5 (Fig. 9.9) every 30,000 km or in case of the engine power decrease.

During maintenance of the air filter, inlet hoses must be carefully protected against ingress of foreign objects, dirt and sand.

The filter cartridge shall be replaced as per the following order:

- loosen the clamp and remove the corrugated hose from the air filter;

- unscrew nuts of clamps 4, remove the clamps and the air filter;

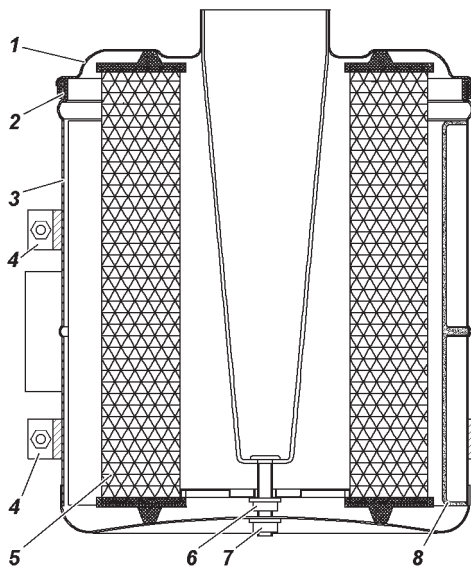

Fig. 9.9. The air filter:

1 — air filter cover; 2 — sealing gasket; 3 — filter housing; 4 — filter fastening clamps; 5 — filter cartridge; 6 — nut; 7 — nut; 8 — air duct

- unscrew nut 7 and take cover 1 with the filter cartridge 5 out of the filter housing;
- unscrew nut 6 and remove the filter cartridge;
- place in the new filter cartridge, re-assemble and re-install the air filter.

A filter with damaged sealing gasket 2 must not be operated.

Fuel supply and ignition control system

To connect engine control system of automated external diagnostics and programming devices, a data link connector covered with protective lid is installed under the hood on the front body panel (Fig. 9.10).

The control unit is installed in the vehicle's interior on the passenger side to the right on the side wall under the decorative board.

Diagnostics

Operation of the engine control system and the injection system depends on the conditions of the mechanical and hydro-mechanical systems. Several deviations leading to faults can be mistaken for electronic control system malfunctions, such as:

- low compression;
- deviation of gas distribution phases caused by an incorrect assembly of engine components;
- air ingress into the inlet and the outlet pipelines;
- poor fuel quality;
- failure to meet the maintenance schedule.

The control unit is capable, to a certain extent, of diagnosing engine control unit components.

If a fault is detected, the control unit turns on the diagnostic fault lamps on the vehicle dashboard, and the code designating the fault is recorded into its memory.

The engine malfunction lamp switching on shall not mean the engine must be stopped immediately, since the control unit has backup modes allowing the engine to work under conditions close to normal.

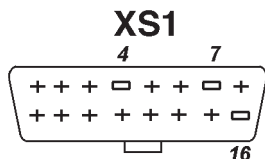

Fig. 9.10. Data link connector (XS1):
4 — ground; 7 — K-line external diagnostics; 16 — +12V

In case of a fault caused by ignition failures (the engine malfunction lamp starts flashing), to avoid exhaust converter failure, it is necessary to reduce the engine crankshaft rotation speed down to 2,500 rpm (the vehicle speed shall not exceed 50 km/h) and to head to a service station. The alarm indicator turns on every time the converter's allowed temperature is exceeded. Furthermore, one or two engine injectors can be turned off.

The engine operation is only allowed after the fault is eliminated.

Diagnostic lamp operation

In the operating mode, with ignition started and engine off, the diagnostic lamp shall be on. If the diagnostic lamp is on with the engine operating, this means the system and the engine need maintenance as soon as possible.

Clearing fault codes.

The memory storing the fault codes can only be cleared using the scanning tester, when the faults are eliminated.

If the rechargeable battery turns off, the control unit self-learning parameters are not lost and can be only cleared using the scanning tester.

When the fault codes are cleared, the controller accumulated adaptive data (the controller self-learning parameters) are cleared automatically.

ZMZ-51432 ENGINE

Engine suspension

In operation, check hermetic-tightness of threaded joints of the front and the rear engine suspensions (see Appendix 2) and the condition of the mounts. No delamination and breakage of the engine mount cushions is allowed.

Gas distribution mechanism

The drive of the camshafts is chain-type double-stage. The first stage is from the crankshaft to the intermediate shaft, the second stage is from the intermediate shaft to the camshafts.

Each chain is pulled automatically by hydraulic tensioners.

Engine lubrication system

If there is a fault in the lubrication system, the operation of the engine must be stopped immediately.

The liquid-oil heat exchanger is provided for oil cooling in the lubrication system.

The lubrication system is filled through the oil filler placed on the cylinder head valve cover.

Regularly monitor the oil level in the crankcase and refill when necessary. Check prior to the starting the engine. If the oil level is to be checked after the engine is stopped, wait for at least 15 minutes to let the oil drain to the crankcase. The vehicle must rest on an even horizontal surface. The oil level shall be between the marks "O" and "P" of oil level indicator 6 (Fig. 9.11). For frequent cross-country trips, maintain the oil level near the "P" mark, without exceeding it.

Replace the oil filter during oil change. The used oil shall be drained from the crankcase immediately after a drive, when it is still hot. Prior to draining, open the oil filler cap. The oil drains for at least 10 minutes.

When fastening the drain hole plug, check condition of the sealing gasket. The damaged gasket shall be replaced with a new one.

Pour the fresh oil up to the upper mark on the oil level indicator and start the engine.

After the oil emergency pressure alarm is turned off, stop the engine, and in 15 minutes check the oil level. If necessary, add more oil.

Please remember, the engine always contains trapped oil. Pour the oil in portions, bringing the oil level at the indicator to the upper mark "P". The volume between the marks "O" and "P" holds about 1 liter of oil. Oil level above the "P" mark is not allowed.

Use only the recommended oils.

Different brands of engine oils and from different manufacturers may not be mixed.

When oil of one grade is replaced with oil of another grade, we recommend that you to flush the engine. When a petroleum oil is replaced with a synthetic oil and vice versa, the engine must be flushed.

To flush the engine lubrication system:

- drain the used oil from the hot engine crankcase;

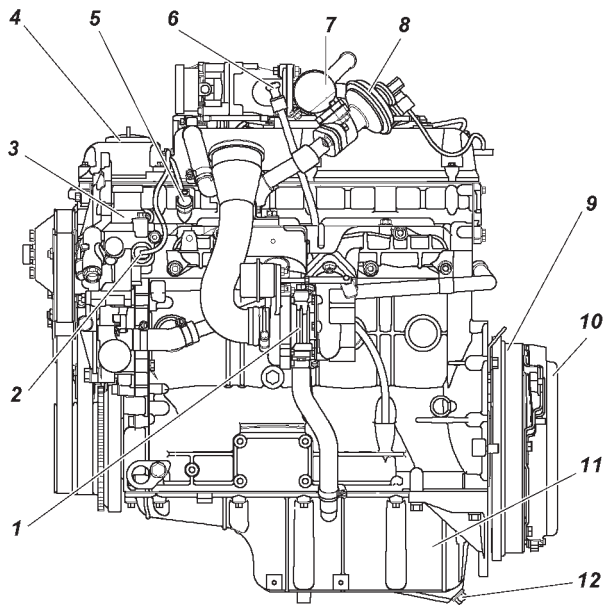

Fig. 9.11. ZMZ-51432 engine (left-side view):

1 — turbocharger; 2 — control system cooling fluid temperature sensor; 3 — temperature control valve housing; 4 — oil filler cap; 5+ — oil incidental pressure sensor; 6 — oil level indicator; 7 — cooler of recirculating gases; 8 — exhaust gases recirculation valve; 9 — flywheel; 10 — clutch; 11 — oil casing; 12 — oil drain plug

- pour the replacement oil or the special washing oil 2-4 mm above the upper mark on the level indicator;
- start the engine and let it run at minimum crankshaft rpm for at least 10 minutes;
- drain the replacement oil or the special washing oil;
- replace the oil filter;
- pour the fresh oil as indicated above.

Oil filter. When replacing, install the 2101S-1012005-NK2 oil filter by KOLAN Company.

When replacing the oil filter, check the hermetic-tightness of the heat exchanger fastening neck nut and tighten, if necessary.

When installing the filter onto the engine, make sure the sealing gasket is in proper condition, lubricate it with oil, and turn the filter until the gasket touches the plane on the heat exchanger and then tighten another 3/4 of a turn. Make sure there is no oil leak in the sealed joints.

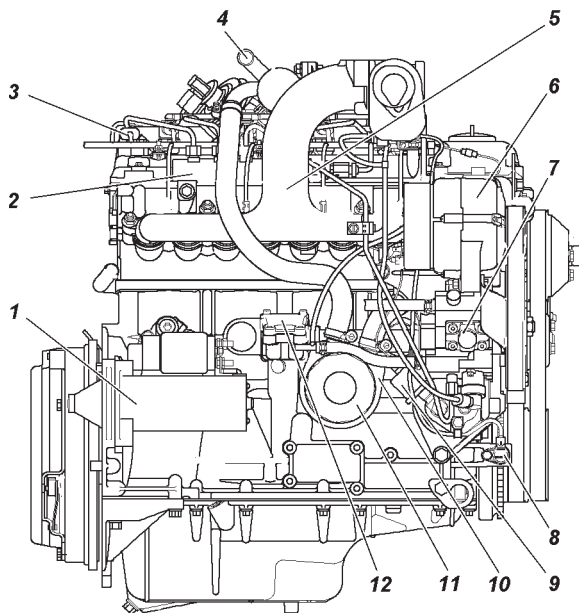

Fig. 9.12. ZMZ-51432 engine (right-side view):

1 — starter; 2 — fuel rail; 3 — phase sensor; 4 — pipe of cooling fluid removal to the heater; 5 — inlet pipe; 6 — generator; 7 — high-pressure fuel pump (HPFP); 8 — timing sensor; 9 — pressure sensor; 10 — liquid-oil heat exchanger; 11 — oil filter; 12 — oil pump drive cover

Crankcase ventilation system

The system maintenance includes a periodic check of the hermetic-tightness of joints and cleaning gum residue off of the system components.

In case of increased oil consumption for burn-out loss and occurrence of black smoke out of the exhaust pipe, check the crankcase ventilation system for proper condition (clogging of channels).

The crankcase ventilation system proper condition is checked using the water piezometer connected to the crankcase via the oil level indicator tube.

In the crankcase of an idle running engine (with crankshaft rpm minimum to maximum), there shall be negative pressure of 1-14 mbar (10-140 mm WG).

If oil traces appear on the joint between the turbocharger and the inlet pipe, check the crankcase blow-by gases pressure.

If the crankcase pressure exceeds 15 mbar (150 mm WG), check the hermetic-tightness of the vehicle vacuum system (vacuum booster and exhaust gas recirculation systems). In case of a leak, the vacuum pump forms gauge pressure in the crankcase, resulting in increased gases flow rate through the oil separator and discharge of oil with the gases.

Increased pressure of crankcase gases can also be due to malfunctions of the cylinder-piston group, and clogging of the crankcase ventilation system components. If this is the case, clean the components.

ATTENTION! *During operation, do not break hermetic-tightness of the ventilation system and do not allow the engine to run with the oil filler opened. This can result in a failure of the turbocharger, contamination of the engine oil chambers, causing increased oil entrainment with crankcase gases, and environmental pollution.*

To clean the crankcase ventilation system, remove the valve cap, the oil separator cap, ventilation hose, and the turbocharger inlet pipe. Flush the removed parts with kerosene and dry out. The oil baffle shall be flushed without disassembling it.

Cooling system

ATTENTION! *The cooling fluid is toxic. Store the fluid in a tightly closed container. The following rules must be observed during work with cooling fluid:*

- *avoid any operations resulting in ingress of the fluid into your mouth;*
- *in case of skin contact, do not let the fluid dry on the skin, and immediately wash it away with warm water and soap;*
- *wash away any spilled fluid with water and ventilate the room;*
- *take off any clothing contaminated with the fluid, dry it outdoors, and then wash it.*

Take care when opening the cooling system expansion chamber plug, to avoid scalding.

For cooling, the following fluid is used: low freezing point fluid TOSOL-A40M, OZh-40 "Lena", or OZh-40 "TOSOL-TS".

When the ambient air temperature is below -40°C, use the low freezing point fluid TOSOL-A65M, OZh-65 "Lena", or OZh-65 "TOSOL-TS".

The cooling fluid operating temperature shall be within 60-110°C. Short-time (maximum of 5 minutes) engine run is allowed at cooling fluid temperature increase to 115°C.

When the cooling fluid overheat alarm turns on, the engine shall not be stopped immediately, to avoid its breakdown. Switch the engine to the idle mode with crankshaft rpm of 1,500...2,000 min⁻¹ for 3...5 minutes for a gradual temperature decrease, and only then stop the engine, detect and eliminate the cause of the overheating of the cooling fluid.

From time to time, check the cooling fluid level in the expansion chamber. The fluid level must be between the marks "min" and "max". Since the cooling fluid has a high thermal expansion coefficient and the cooling fluid level in the expansion chamber varies significantly, depending on the temperature, check the level when the system temperature is plus 15-20°C.

When the cooling fluid in the expansion chamber has decreased within a short period or after moderate travel (up to 500 km), check the cooling system hermetic-tightness and after elimination of leaks, add the same cooling fluid into the radiator or the expansion chamber.

In exceptional cases, e.g., major leak of cooling fluid, short-time filling with pure fresh water into the cooling system is allowed. Sea water may not be used, nor alkali to soften the water, since it corrodes the engine's aluminum parts. Prior to use, filter the water using the materials at hand. As soon as possible, drain the water completely, flush the cooling system, and fill it with the cooling fluid specified in Appendix 3.

ATTENTION! *The Manufacturer shall not bear responsibility for the breakdown of parts caused by freezing of water in the cooling system.*

The cooling system shall be flushed as follows:

- fill the system with pure water, start the engine, let it work until warm, stop the engine and drain the water;
- repeat the above operation.

Due to presence of air in the interior heater, the temperature booster and connection hoses, the cooling system shall be charged as per the following procedure:

- close the cooling fluid drain plugs;
- switch the interior heater valve actuating lever into position "open";
- fill the system with the cooling fluid. The fluid level in the expansion chamber shall be below the mark "max";

- start the engine, add the cooling fluid to the radiator expansion chamber when its level decreases, and close the plug;
- stop the engine, let it cool down, raise the cooling fluid level in the expansion chamber to the standard, and close the expansion chamber plug;
- run 2-3 cycles of the engine warm-up — cool-down, and again raise the cooling fluid level in the expansion chamber to the standard.

The fluid from the cooling system is drained through two holes closed with plugs 12 and 16 (Fig. 9.13).

ATTENTION! *The engine may not be operated without the temperature control valve (without one, the engine runs with the cooling fluid at decreased temperature, which results in the engine components increased wear and increased fuel consumption).*

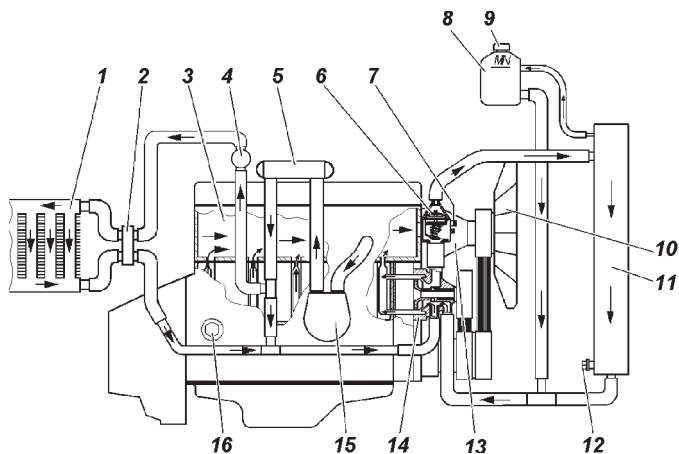

Fig. 9.13. The engine cooling system pattern:

- 1 — interior heater radiator; 2 — passenger compartment heater tap; 3 — engine; 4 — heating system additional pump; 5 — cooler of recirculating gases; 6 — temperature control valve; 7 — cooling fluid temperature sensor; 8 — expansion chamber; 9 — expansion chamber plug; 10 — fan; 11 — cooling system radiator; 12 — drain plug; 13 — fan drive; 14 — pump; 15 — liquid-oil heat exchanger; 16 — drain plug on the cylinder block

Replacement and tension of drive belts of the power steering fan and pump, generator, cooling system pump, and high-pressure fuel pump (HPFP)

From time to time, check the tension and condition of the belts. Replace the belts when damaged or over-tensioned.

The power steering fan and pump drive belt shall be tensioned as follows:

- loosen bolt 4 (Fig. 9.14);
- by turning one of the tension rollers 3, bring the belt tension to the required value (for standard values, see Table "Specifications");
- tighten bolt 4.

If you cannot achieve the specified tension using one roller, use the second roller.

The belt shall be replaced as per the following procedure:

- loosen bolts 4;
- by turning the rollers 3, release the belt tension;
- replace the belt and tension it as specified above.

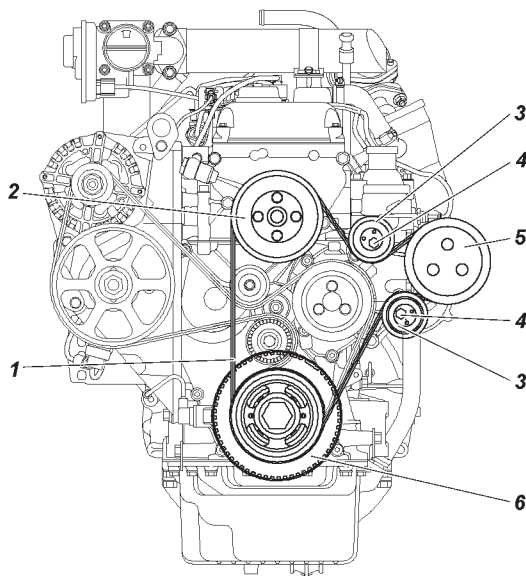

Fig. 9.14. Belt of the power steering fan and pump drive:
1 — power steering fan and pump drive belt; 2 — fan pulley; 3 — tensioning roller; 4 — bolt; 5 — power steering pump pulley; 6 — crankshaft damping pulley

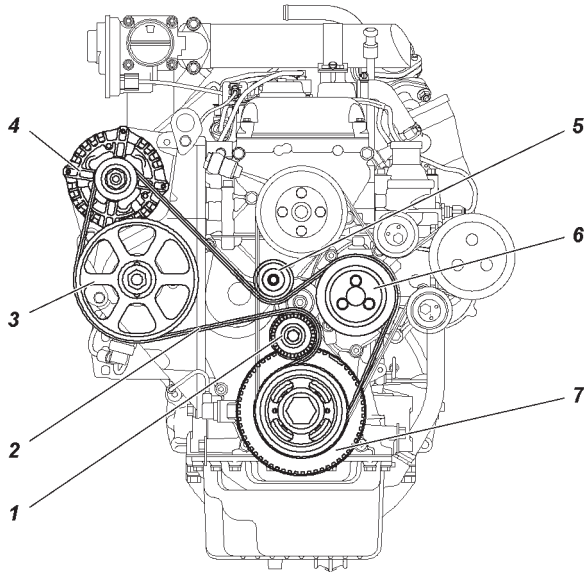

Fig. 9.15. Belt of the generator, cooling system pump and HPFP drive:
 1 — automatic tensioner; 2 — HPFP and water pump drive belt ; 3 — HPFP pulley; 4 — generator pulley; 5 — run-around roller; 6 — water pump pulley; 7 — water pump pulley

The generator, the cooling system pump and the HPFP drive belt 2 (Fig. 9.15) tension is ensured by the automatic belt tensioner 1. No maintenance or adjustment of the automatic tensioner is required during operation.

The belt shall be replaced as per the following procedure:

- insert the hex driver into the automatic tensioner 1 roller socket;
- turn the tensioner lever releasing the belt tension;
- hold the lever in this position and replace the belt.

EXHAUST SYSTEM

ATTENTION! The converter operating temperature shall be 400-600°C. The vehicle may not be operated if no protective screen is installed on the converter. When the vehicle is in motion and in standstill, ensure that the exhaust system has no contact with flammable materials (e.g., dry grass).

Leak of exhaust gas in the exhaust system connections, fitted with gaskets, is not allowed and shall be eliminated when it first occurs. Stuck nuts shall be tightened (see Appendix 2) with preliminary wetting of thread connections with special liquids or kerosene.

Vehicle modes, in which ingress of unburnt fuel into the exhaust system is probable are not allowed.

Pay special attention to operation of the fuel system, the valve control system, and the inlet system.

Exhaust gas recirculation system

The exhaust gas recirculation system (Fig. 9.16) serves to reduce emissions of toxic nitrogen oxides with exhaust gases through a supply of part of the exhaust gases from the exhaust manifold to the engine cylinders.

The system operation is controlled by the microprocessor-based control unit using the indications of the sensors of the

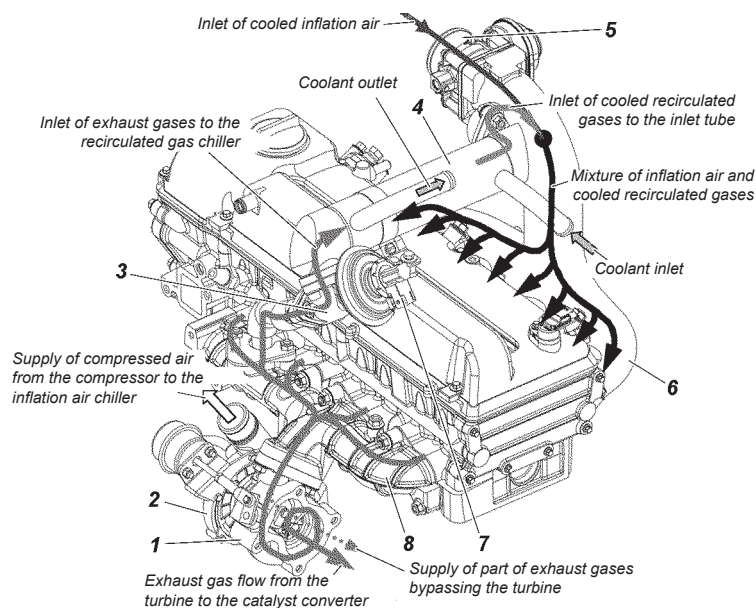

Fig. 9.16. Exhaust gases recirculation system pattern
 1 — turbine; 2 — compressor; 3 — recirculation valve; 4 — recirculating gases cooler; 5 — air supply pipe with throttle gate; 6 — inlet pipe; 7 — valve stem position sensor; 8 — exhaust manifold

cooling fluid temperature, the accelerator pedal position, the crankshaft rpm, and also data recorded in its memory.

ATTENTION! *No engine may be operated if the exhaust gas recirculation valve and the brake booster vacuum hoses are disconnected or not tight, since this results in the rise in crankcase pressure and increased oil consumption due to burnt-out loss.*

Inspecting smoke at the exhaust

Smoke at the exhaust shall only be checked at a service station.

Microprocessor-controlled fuel injection system

ATTENTION! *Use only diesel fuel complying with the requirements of GOST R 52368. Various additives (including gasoline, kerosene, etc.) for fuel may not be used. If the above requirements are not met, UAZ PJSC shall bear no warranty responsibility in case of the fuel equipment failure.*

Precautions.

1. Prior to dismantling and installation of any components or wires of the control system, disconnect the rechargeable battery ground wire.

2. The engine may not be started if the rechargeable battery and the ground wire between the engine and the body are not connected reliably.

3. The rechargeable battery may not be disconnected from the vehicle's electrical network while the engine is running.

4. If being charged from an external source, the rechargeable battery must be disconnected from the vehicle's electrical network.

5. The control unit may not be exposed to temperatures above 80°C, e.g., in an oven dryer.

6. Prior to arc welding operations, disconnect the battery wire and the control unit connector.

7. To prevent rusting of pins during vapor cleaning, do not direct the nozzle towards system components.

ATTENTION! *The fuel line joints may not be loosened or tightened with the engine running or immediately after it stops.*

Fuel system

ATTENTION! *The fuel may not be burnt completely out of the fuel system since the HPFP contact parts are lubricated with fuel.*

To the high-pressure fuel pump, the fuel comes from the right-side tank through the final fuel filter. As fuel is consumed, the right-side tank is refilled from the left-side one automatically.

The plugs of the fuel tanks filling pipes necks are blind and ensure tight packing.

The following is recommended, due to the specified features of the fuel system design:

- when closing the tank filler necks, make sure the plugs are in good condition, the sealing gasket is present and undamaged, and ensure tight closing of the plugs through the application of adequate force;

- for partial fuelling of the vehicle, start from the right-side tank;

- monitor the fuel consumption with due account for variation of the fuel amount in both tanks.

Fuel tanks 4, 22 (Fig. 9.17). Maintenance of the fuel tanks includes periodic flushing of the fuel level indicator inlet tube filter (right-side and left-side tanks) and flushing of the tanks themselves.

From time to time, drain the settling by unscrewing the plug in the tank bottom part.

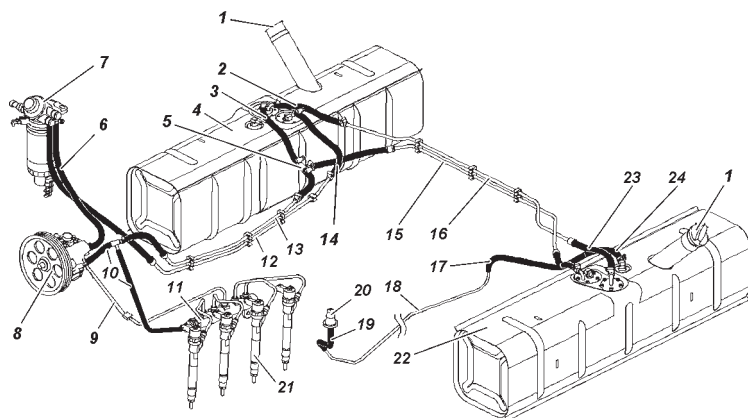

Fig. 9.17. The engine fuel system pattern

1 — fuel tank plug; 2, 17, 19, 23, 24 — vapor-air hoses; 3 — hose of fuel drain into the right-side tank; 4 — right-side fuel tank; 5 — jet pump; 6, 14 — fuel feed hoses; 7 — final fuel filter; 8 — high-pressure fuel pump (HPFP); 9 — fuel tube; 10 — fuel drain hose; 11 — fuel rail; 12 — fuel feed tube; 13 — fuel drain tube; 15 — tube from the left-side tank to the jet pump; 16, 18 — vapor-air tubes; 20 — fuel tank valve; 21 — injectors; 22 — left-side fuel tank

Check from time to time the reliability of the tanks' fastening and, if necessary, tighten the fastening bolts.

To be flushed, the fuel tanks shall be dismantled from the vehicle.

Prior to dismantling of the tanks from the vehicle, do the following:

- disconnect the rechargeable battery;
- drain the fuel by unscrewing the plugs on the tanks bottoms;
- open the hatch in the body's floor and disconnect the block from the fuel level indicator sensor;
- disconnect the fuel lines tubes and hoses.

Then unscrew the bolts of the fuel tanks bands, bend the bands down, so they do not obstruct the tank lowering, and remove the tank.

The tank shall be re-installed in reverse order.

Pay special attention to the fuel system hermetic-tightness and the reliability connection to the "ground".

It is not recommended to operate the vehicle, if there is less than 5 liters of fuel in the right-side fuel tank.

When traveling over steep climbs, there must be at least 20 liters of fuel in the right-side tank.

Clogging of the final fuel filter, presence of dirt and mechanical admixtures in the fuel tank, appear, first of all, due to deterioration of the pumping of the fuel from the left-side tank into the right-side one, unstable engine operation at high loads, and degradation of vehicle performance.

Note. At ambient air temperature of below 0°C, the clogging signs can be due to water presence and freezing in the fuel system. If water was detected in the fuel, drain the fuel and flush the fuel tanks with pure fuel.

Jet pump. Check from time to time the hermetic-tightness of the pump and its connections. If the fuel is not pumped from the left-side tank into the right-side one, disassemble the pump (unscrew the orifice), flush it and purge with air.

The jet pump is fastened on the fuel hoses near the frame's right side member.

Joint leak shall be rectified through tightening of the worm drive joints of clamps, or by replacement of faulty components.

Upon completion of any fuel feed system maintenance operations related to tightening of clamps' connections, removal

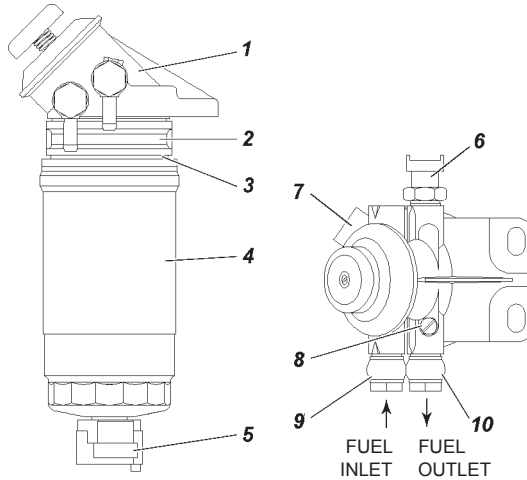

Fig. 9.18. Final fuel filter with priming pump and water-in-fuel presence indicator in the settling drain plug:

1 — manual priming pump; 2 — heater; 3 — gasket; 4 — replaceable filter cartridge; 5 — settling drain plug with water presence indicator; 6 — fuel temperature sensor; 7 — heater pin connector; 8 — air release screw; 9 — fuel supply nozzle; 10 — fuel removal nozzle

or replacement of parts and assemblies, the system hermetic-tightness must be checked as follows:

- make sure the filler caps are securely tightened;
- tighten the clamps and threaded joints until hermetic-sealing is ensured;
- for initial filling of the fuel system, use the priming pump on the final fuel filter. Air shall be drained through the screw of the final fuel filter 7 (Fig. 9.18);
- start the engine, and with it running at idle, visually check the system. Fuel leaks or the wetting of fuel system components is not be allowed.

For the final fuel filter use BOSCH, 0 450 126 273, shown in Fig. 9.18.

Heating is controlled automatically using the fuel temperature sensor 6.

Every 5,000 km remove the sediment from the filter (unscrew plug 5, drain the settling until pure fuel flow appears, and screw back the plug).

Every 15,000 km, replace the filter cartridge.

Prior to replacement, remove dirt from the outer surface of the filter. When replacing the filter cartridge, prevent ingress of dirt into the cavity of the filter body.

For replacement, use filter cartridge 1 457 434 310 by BOSCH Company.

Replacement of the filter cartridge:

- drain fuel from the filter by turning the water drain plug 5 several turns;

- unscrew the filter cartridge 4;

- lubricate gasket 3 on the housing of the new filter cartridge with pure diesel fuel oil;

- screw on the new filter cartridge and tighten with the torque of 20-25 N · m (2-2.5 kgf · m).

Releasing air from the fuel system.

Air must be released from the system in the following cases:

- dismantling of pipelines, filters or pumps;

- upon replacement of the fuel filter cartridge;

- upon complete fuel burnout of the system.

To release air and fill the system with fuel, the following operations must be done:

1. Make sure the fuel plugs of tanks are tightened securely.

The fuel tank filler plugs are blind and ensure tight sealing.

2. Loosen the air release plug 5 on the final fuel filter (FFF).

Using a manual priming pump 1 on the FFF, fill the main line until air bubbles disappear from the fuel going from beneath the air release plug.

3. Tighten the air release plug 5.

4. Start the engine with starter until steady engine operation.

5. If the engine did not start due to the fact that the high-pressure tubes are not filled with fuel, you must:

- loosen the fastening nuts of the tubes on the orifices;

- by turning the crankshaft with the starter, fill the tubes with fuel (continuous starter operation time must not exceed 15 seconds) and in the course of the engine turning with the starter, ensure complete feed of the fuel by pressing on the accelerator pedal to the limit, with retention of gauge air pressure in the tanks;

- if fuel leaks from beneath the high-pressure nuts of tubes, stop turning the crankshaft;

- tighten the nuts;

- start the engine.

It is recommended to install the high-pressure fuel lines onto the engine only once. Repeated installation will not ensure the secure sealing of joints and long-term fuel line operation.

High-pressure fuel pump (HPFP).

The HPFP and orifices maintenance, adjustment, inspection and repair are recommended to be carried out in BOSCH service centers. Independent adjustment, partial or complete disassembling of the HPFP is not allowed.

ATTENTION! *It is prohibited to unscrew the central fastening nut of the HPFP pulley hub and to remove the HPFP pulley with the hub. If removed, the hub cannot be installed into the correct position, which results in significant deterioration of engine performance and can lead to engine breakdown.*

Accelerator pedal drive. The UAZ-315148 has an electronic module for the accelerator pedal, which does not require adjustments.

Air filter. For filter maintenance, see section "ZMZ-40905 Engine".

Turbocharger

To prevent turbocharger damage, the engine may not be operated without the air filter or with the air filter damaged.

If the engine is operated with the recommended lubricating oils, the TCR service life is the same as that of the engine.

ATTENTION! *When the engine is stopped after long-term operation at high rpm or high load, you must let the engine run at idle minimum rpm for 3-5 minutes, to prevent the premature failure of the turbocharger.*

ATTENTION! *Do not allow the engine to run at idle minimum rpm for more than 10 minutes, since due to negative pressure created by the cylinder-piston group, the air pressure inside the turbocharger housing is established below the atmospheric pressure. Some lubricating oil from the housing of turbocharger bearings, through the wheel labyrinth seal, enters the engine inlet system, leading to its increased smoking.*

To avoid the engine failure, it is strongly prohibited to adjust the TCR bleed valve.

You may not adjust the turbocharger pneumatic chamber rod length using the nut. The rod length is strictly tuned by the manufacturer of turbochargers and modifying its length will lead

either to a drop in engine power or to a sharp increase of the load on the crank mechanism parts and the premature failure of the engine.

The gas turbo-charging system maintenance includes regular checks of hermetic-tightness of the receiver connection with the HPFP charging corrector. If the corrector is inoperative, the engine loses up to 30 % of its power.

It is also important to check and replace the air intake filter cartridge routinely, in accordance with the terms specified by the Engine Operation Manual.

Engine control system

This is designed for engine starting, and control while the vehicle is in motion or stopped.

The main functions of this system are:

- fuel feed control;
- control of the operation of heating plugs — to ensure engine start and warming;
- control of recirculation of exhaust gases — to reduce nitrogen oxides content in emitted exhaust gases;
- control of the heating plugs turning-on indication lamp on the vehicle dashboard;
- control of the engine control system faults indication lamp on the vehicle dashboard;
- diagnostics of the engine control system.

Engine control system and its diagnostics

The main component carrying out the control process is the microprocessor-based control unit. The control unit issues the control signals based upon the data acquired from the sensors of the system monitoring the state of the engine, the vehicle and the environment. The control unit is installed in the vehicle cabin to the right on the front body panel.

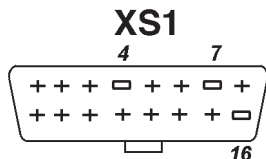

Fig. 9.19. Data link connector (XS1):
4 — "ground"; 7 — K-line of external diagnostics; 16 — "+12V"

To connect the engine control system automated external diagnostics and programming devices, the data link connector is installed under the hood on the front body panel (Fig. 9.19).

The control unit is capable of a certain amount of diagnostics of the engine control system components. When a fault is detected, the control unit switches on the faults warning lamps V and X (see Fig. 3.1) on the vehicle dashboard, and the code designating the fault is recorded in its memory.

ATTENTION! *When the "EDC" fault warning lamp is turned on, the engine must not be operated. Stop the vehicle as soon as feasible and shut off the engine. The vehicle may only be operated after the fault is eliminated.*

When the "OBD" engine fault warning lamp is constantly on, the engine components or the exhaust system components, affecting the exhaust gas toxicity, are faulty. If the warning lamp is on and no significant deterioration of ride performance is observed, you can continue motion at a low speed to the nearest UAZ authorized service station to seek diagnostics.

Long-term operation, with the warning lamp constantly on, results in the failure of the engine control system components.

TRANSMISSION

When moving at a slow speeds, at 1st-2nd gears of the gearbox in acceleration-deceleration regime, audible knock in the form of short clicks may occur in the driving system.

When moving at higher gears of the gearbox and the transfer case at speed higher than 60 km/h in engine braking regime, as well as during free running (neutral position of the gearbox), the noise in the transmission system in the form of slight low-frequency hum may occur; slight momentary rattling of the transfer case shifting lever may appear.

During brisk acceleration of the vehicle, a slight knock may occur during the selection of gaps in the spline coupling of the transmission system.

During engine braking, a slight knock may occur during the selection of gaps in the spline couplings of the transmission system.

During free running and subsequent brisk acceleration of the vehicle, a slight knock of synchronizer rings of the gearbox may occur.

Clutch

During abrupt release of the clutch pedal, a single knock may occur, because of the selection of the side gaps in tooth gear couplings, spline couplings and in synchronizers of the gearbox.

The level of the fluid must be 15-20 mm lower than the upper edge of the reservoir 2 (Fig. 9.20).

Incomplete clutch release and pedal "softness" indicate a presence of air in the hydraulic system. Perform bleeding of the system through the bypass valve of the clutch release cylinder, similar to air bleeding of the hydraulic brake system.

Perform adjustment of the clutch release pedal by changing the length of the master cylinder push rod 5 (See Fig. 9.20). Full travel of the clutch release pedal with the diaphragm spring must be 150 ± 20 mm. Full travel of the clutch release pedal with the spring and drawback lever must be 185 ± 20 mm.

The free travel of the clutch release pedal with the diaphragm spring (5-30 mm) is maintained by the clutch design and needs no adjustment.

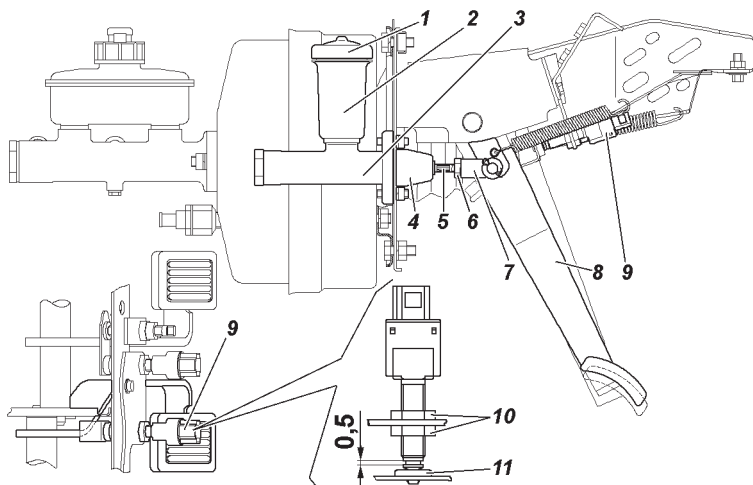

Fig. 9.20. Drive of master cylinder clutch release:

1 — tank cap; 2 — tank housing; 3 — master cylinder housing; 4 — protective cap; 5 — push rod; 6 — nut; 7 — push rod sleeve; 8 — clutch releasing pedal; 9 — switch of clutch pedal; 10 — nuts; 11 — buffer

The switch of the clutch release pedal 9 is adjusted by nuts 10, providing a gap of 0.5 mm, indicated in the figure. After the adjustment, tighten the nuts with torque 4-6 N · m (0.4-0.6 kgf · m).

The gearbox and the transfer case

During abrupt gear engagement/shift, a single knock may occur in the gearbox.

During a sudden engagement of the front axle when driving, a slight knock may occur in splines of the sleeve of the front axle engagement.

During a sudden front axle de-clutching, a slight single knock in the transfer case may occur.

When driving at a lower gear, the transmission noise is louder, than when driving on the direct transfer of the transfer case.

Periodically check threaded couplings for proper fastening.

If a leak is detected, find out the reason and replace the defective parts (spacers, collars).

To change the oil in aggregates, drain it immediately after the vehicle stops and the aggregate is hot, unscrew the filler plug first.

To check the oil level in the gearbox, unscrew plug 3 (Fig. 9.21) or 5 (Fig. 9.22). The oil level should reach the lower edge of the filler orifice.

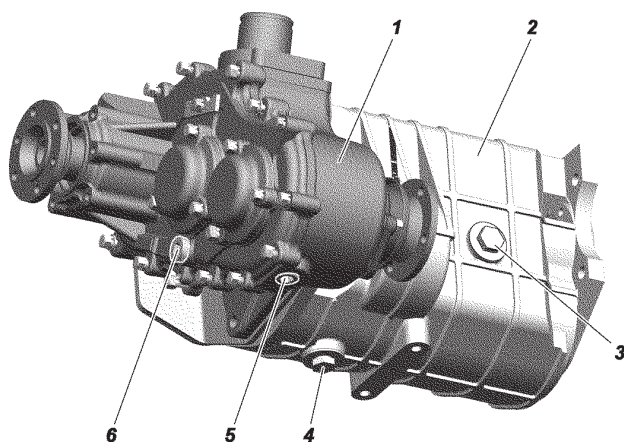

Fig. 9.21. Five-speed gearbox made in China and the transfer case:
1 — transfer case; 2 — gear box; 3 — gearbox housing filler plug; 4 — gearbox housing drain plug; 5 — transfer case housing drain plug; 6 — transfer case housing filler plug.

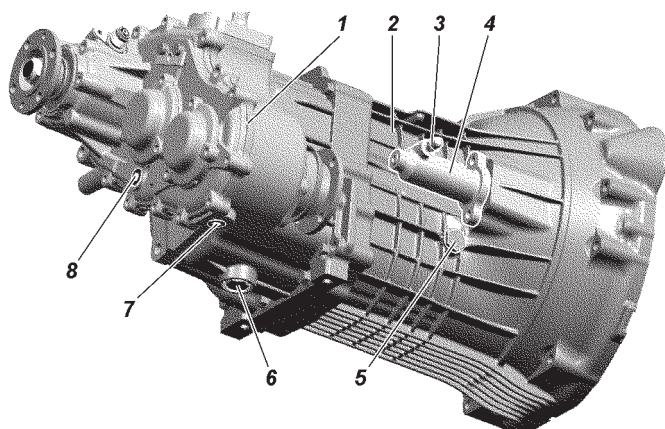

Fig. 9.22 Clutch release slave cylinder, five-speed Dymos gearbox and transfer case:
1 — transfer case; 2 — gear box; 3 — transfer valve; 4 — clutch release cylinder; 5 — gearbox housing filler plug; 6 — gearbox housing drain plug; 7 — transfer case housing drain plug; 8 — transfer case housing filler plug

To check the oil level in the transfer case, unscrew plug 6 (Fig. 9.21) or 8 (Fig. 9.22). The oil level should reach the lower edge of the filler orifice.

During installation of the drain plug 6 (Fig. 9.22) of the gearbox into its position, change the spacer.

WARNING! *The same oil is used in the gearbox made in China and in the transfer case (see Appendix 3). Checking and changing oil in the gearbox and the transfer box should be done simultaneously. The level of oil in the gearbox could flow into the transfer case up to 0.325 l (the level of the oil in the gearbox lowers simultaneously with its rising in the transfer case).*

WARNING! *Different oils are used in the Dymos gearbox and in the transfer case (see Appendix 3), mixing is not allowed.*

Drive shaft

The spline coupling is lubricated through grease pump 1 (Fig. 9.23), and the needle bearings are lubricated through grease pumps 2 on center crosses.

Lubricate the needle bearings until the grease shows up from under the working edges of the center cross collars.

Applying solid oil and mixtures, or its contents for lubrication of the needle bearings could lead to premature failure of the needle bearings.

Do not apply too much grease to the splined couplings, as it would bleed through the spline coupling, and that would provoke a premature failure of the oil seals and could eject the plug of the slip yoke.

Use a special tip to be fitted on the grease gun to lubricate the knuckles.

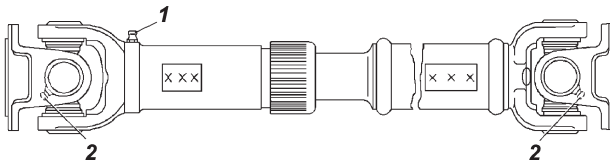

Fig. 9.23. Rear drive shaft:

1- grease pump for spline coupling lubrication; 2 — grease pump for needle bearings lubrication of the joint

Driving axles

Check the oil level in the housing. It should reach the lower edge of the filler orifice.

Drain the oil through orifice 2 (Fig. 9.24) at the bottom of the housing by unscrewing the filler plug 1.

Axial clearance of more than 0.05 mm in the bearings of the axle drive pinion is not allowed, as greater clearance would provoke premature gear teeth wear and that could result in the axle jam. Check the axial clearance in the bearings by swinging the drive pinion by universal-joint flange.

Axial clearance in the differential bearings of the final drive is not allowed either. Check the clearance by swinging the drive pinion when the housing cap is removed.

If a gap is detected, the axle should be adjusted. The axle adjustment is a labor-intensive operation requiring specific skills and instrument, that is why we recommend to conduct axle adjustments only at a service station.

During the inspection of the steering knuckles, check the serviceability of the adjusting bolts 1 (Fig. 9.25) and steering stop bolts 3. The value of the steering angle B of the right wheel to the right, and of the left wheel to the left should be within the limits of 26-27°. A greater steering angle of the wheels results in the contact of the wheel with suspension parts.

It is not required to add grease into the spherical pins and into the ball struts during operation. The grease in the units is replaced during maintenance.

The adjustment of the tightening of the steering knuckle pins at the factory is carried out with preliminary tightening along the common axle shaft of the pins.

During the operation of the vehicle, pay special attention to the condition of the tightening of the steering knuckle pins. Upon wear of the interacting spherical surfaces of the liners 3 (Fig. 9.26) or pins 2, the preliminary tightening disappears and the gap appears along the common axle shaft of the pins. To remove the gap tighten clamping bushing 10.

Operating the front driving axle with gaps in the pins units can lead to a premature failure of the liner of the upper pin.

During the operation, it is easier to tighten the clamping bushing of the lower pin:

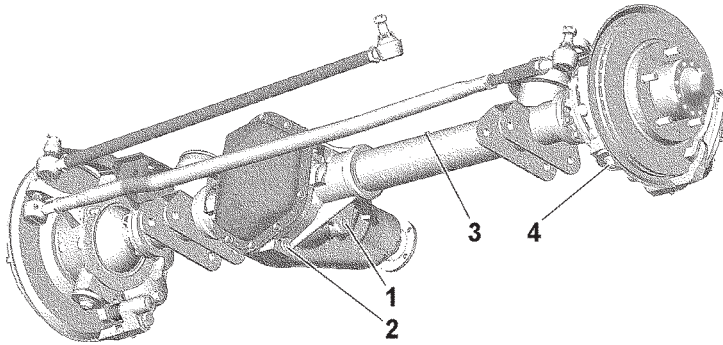

Fig. 9.24. The front axle:

1 — filler plug; 2 — drain plug; 3 — safety valve; 4 — lower pin nut

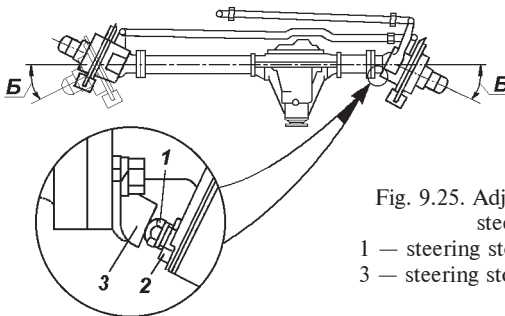

Fig. 9.25. Adjustment of the wheels steering angle:

1 — steering stop bolt; 2 — lock-nut ;
3 — steering stop

- unscrew nut 13;
- remove shield 12 with spacer 11;
- using a special wrench, tighten clamping bushing 10 to remove gap (preliminarily hitting the threaded end of the pin with a copper hammer);
- by turning the wrench by 10-20°, tighten this bushing to obtain a preliminary tension along the common axle shaft of the pins;
- install shield 12 with spacer 11;
- tighten the nut of pin 13 with the torque force of 80-100 N·m (8-10 kgf·m) (see Appendix 2). Warning! Exceeding of the tightening torque can lead to weakening of the preliminary tension and failure of the pin unit.

The torque force of ball strut 8 (or housing 1 of the steering knuckle, if the ball struts were not disconnected from the housing of the axle shaft) in any direction, relative to the common axle shaft of the pins, should be within the limits of 10-25 N·m (1.0-2.5 kgf·m) considering the removed O-rings 5, 6 and joint 7 of the steering knuckle.

If the critical parameter is not reached, tighten the clamping bushing once again by turning the wrench by 10-20° and tighten nut 13 with the specified torque.

If the gap is not removed after the tightening of the threaded bushing, the replacement of the liners of the pins units is needed. You should contact the UAZ service station.

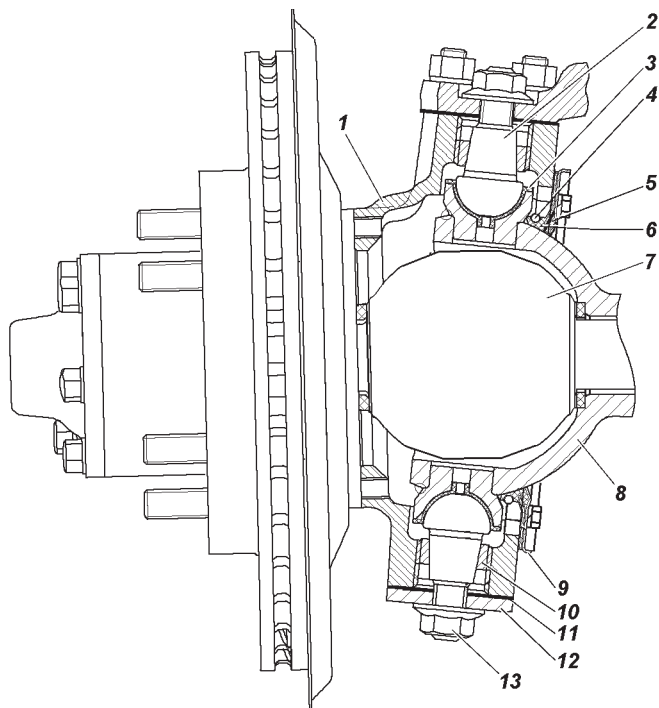

Fig. 9.26. Steering knuckle and wheel hub:

1 — steering knuckle housing; 2 — pin; 3 — pin liner; 4 — spring; 5 — outer O-ring; 6 — inner O-ring; 7 — joint; 8 — ball strut; 9 — outer seal housing; 10 — clamping bushing; 11 — spacer; 12 — plate; 13 — nut

CHASSIS

Suspension

The front dependent spring suspension on trailing arms with torsion bar stabilizer (Fig. 9.27) , the rear leaf-spring suspension (Fig. 9.28).

Maintenance-free hydraulic shock absorbers are mounted on the vehicle. If the shock absorber fails: leaking shock absorber liquid, loss of power — the shock absorber should be replaced. Disassembly of shock absorbers is prohibited. Place the shock absorbers of the same identification on one axle shaft. The front and the rear shock absorbers are not interchangeable.

Motor vehicle operation with a faulty shock absorber or without a shock absorber is prohibited.

Periodically check the tightening torque of the mounting nuts of the suspension joints (lateral rods, trailing arms, leaf-springs). The reduced tightening torque can lead to the premature wear of the pins and the mounting parts, and to deterioration of vehicle handling.

Knocks and squeals in the joints, increased backlashes in the couplings, deterioration of vehicle handling indicate a wearing of the joints and the necessity to replace them. Strains on the lateral rod of the suspension, the tie rod, the trailing arms of the suspension and the brackets of the suspension leading mechanism are not allowed during operation.

During removal and installation of the suspension members and replacement of the joints, it is recommended to carry out

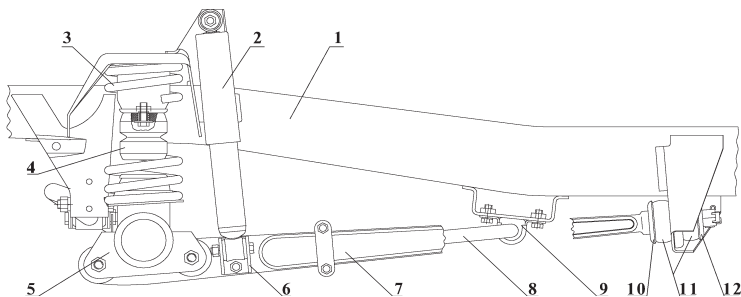

Fig. 9.27. The front dependent spring suspension:

- 1 — frame; 2 — shock absorber; 3 — spring; 4 — buffer; 5 — axle assembly; 6 — shock absorber lower bracket; 7 — trailing arm; 8 — stabilizer rod; 9 — stabilizer rod housing with seat; 10,12 — trailing arm rear-end washer; 11 — supporting bushing.

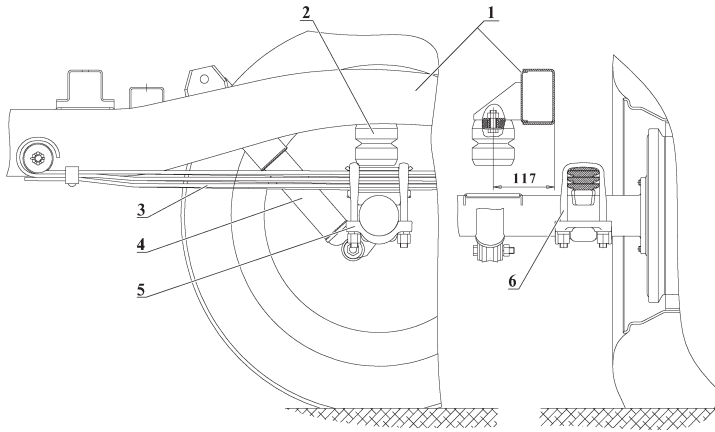

Fig. 9.28. Rear suspension:

1- frame; 2 — buffer; 3 — leaf-springs; 4 — shock absorber; 5 — leaf-spring U-bolt; 6 — U-bolt.

a final tightening of the nuts of all joint couplings and the leaf-spring U-bolt nuts on the vehicle, standing on the wheels. This ensures normal working condition of the joints and decreases wear. The tightening torques of the threaded couplings are shown in Appendix 2.

During installation of the front suspension spring, check that the springs are installed precisely in their seats, and as required, turn the spring seat, on which the upper end of the spring is leaned around the axis in one way or another.

When removing the suspension compression buffers and their re-installation, ensure the safety of their lock by using thread sealant compound or lock washers.

Wheels and tires

WARNING! *Tires of various models (tread patterns) may have different sizes and stiffness characteristics, use identical tires on all wheels.*

To provide uniform tightening of the nuts, tighten them alternatively, — every second one.

Check inflation pressure in cold tires.

If intensive uneven wear of the front wheel tire is detected, check and adjust the toe-in of the front wheels and the gaps in the pins units.

Adjust the toe-in of the tire at the normal tire inflation pressure. Carry-out the adjustment at a special stand. In the absence of a stand, carry-out the adjustment in such a way that the dimension A (Fig. 9.29), measured by the center line of side surface of the tire in front is 0.5-1.5 mm less than the dimension B behind. Adjust the toe-in of the wheels by changing the length of the steering tie rod; then, having loosened lock-nuts 1 and 3 provided with the left-hand and right-hand thread, rotate connecting sleeve 2 (Fig. 9.30). Upon adjustment tighten the lock-nuts.

During the operation (after 10,000 km of travel) carry out tire rotation to provide uniform tire wear.

When rotating the radial tires, rotate the front and rear wheel tires separately for each side. Do not introduce the spare wheel tire (it can be used only in case of a excessively worn-out tire).

Wheel hubs

Rock the wheel to detect play in bearings.

Pay special attention to correct adjustment of the wheel hub bearing after running-in.

For changing grease, remove the hub from the pins, remove old grease, thoroughly wash the bearings and fill the space between the rollers with fresh grease. Apply 10-15 mm grease between the bearings. Do not apply too much grease to the hub, to avoid its ingress into the brake mechanism.

Adjust the wheel hub bearings in the following sequence:

1. Jack up the wheel, whose bearings are to be adjusted.
2. Remove the wheel coverage. Take out axle shaft 9 (Fig. 9.31) of the rear axle or remove the driving flange of the front axle.
3. Unbend the tab of locking washer 6, loosen lock-nut 7 and remove the locking washer.
4. Loosen the bearings adjustment nut $4 \frac{1}{6}$ - $1\frac{1}{3}$ of a turn (1-2 sides).

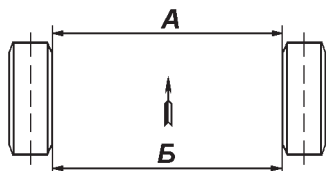

Fig. 9.29. Toe-in

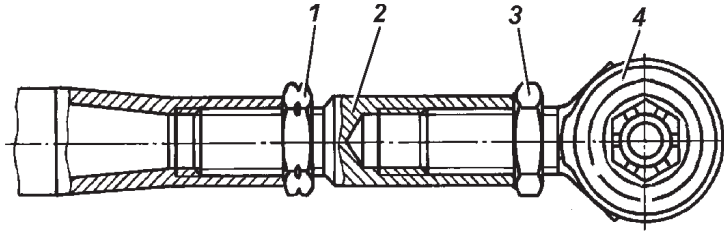

Fig. 9.30. Steering tie rod:

1 — left-hand thread lock-nut ; 2 — adjusting connection; 3 — right-hand thread lock-nut ; 4 — joint

5. Rotate the wheel by hand to check it for easy turning (the wheel should rotate freely without the brake shoes rubbing against the brake plate or the drum).

6. Tighten the adjusting nut of the hub bearings with the aid of a wrench and the tommy-bar 300-350 mm long, applying one hand effort until the wheel is rotated with difficulty.

When tightening the nut, apply the effort to the tommy-bar smoothly, without jerks and simultaneously rotate the wheel to

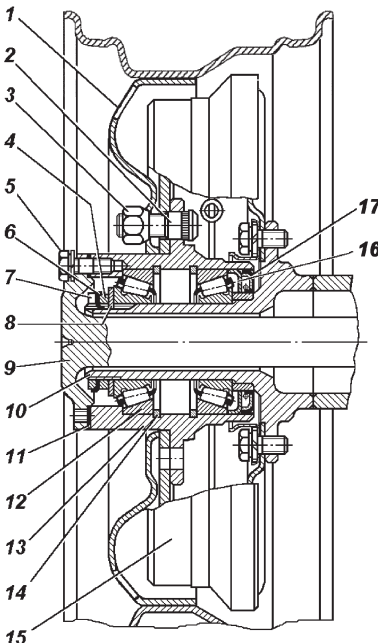

Fig. 9.31. Rear wheel hub:

1 — wheel; 2 — wheel hub bolt; 3 — wheel fastening nut; 4 — adjusting nut; 5 — axle fastening bolt; 6 — lock washer; 7 — lock-nut ; 8 — thrust washer; 9 — axle; 10 — pin; 11 — spacer; 12 — bearing; 13 — wheel hub; 14 — thrust ring; 15 — brake drum; 16 — thrust washer; 17 — collar

allow the rollers to assume correct position on the races of the bearings.

7. Unfasten the nut for 1/4-1/3 turn (1.5-2 flats), install the locking washer, screw in and tighten the lock-nut . The tightening torque of the lock-nut is 20-30 N · m (2.0-3.0 kgf · m). The tightening torque of the lock-nut at the replacement of the bearing is 30-40 N · m (3.0-4.0 kgf · m). Install the locking washer with its inner tab into the pon groove.

Replace the locking washer if some cracks on the tabs of the locking washer are detected.

8. Check the adjustment of the bearings after tightening the lock-nut. If the adjustment is correct, the wheel should rotate freely without binding, noticeable axial play or wobbling.

9. Bend one tab of the lock washer around the flat of the nut, bend the second tab around the flat of the lock-nut until full fitting to the flats. Unbend those tabs of the lock washer that are the closest to the middle of the nut flats.

10. Reinstall the axle shaft of the rear axle or the driving flange, clear the threaded parts of the bolts from the residues of the thread sealant compound, degrease and apply new hermetic UG-6, and tighten the bolts. Reinstall the wheel hub.

After a run, make the final check of the wheel hub for correct bearings adjustment by checking how much it heated up. If the hub overheats (the hand cannot stand the heat), unfasten the nut 1/6 of a turn (1 flat), observing the above sequence and rules.

When checking the bearing adjustment by feeling the heat of the hub, do not apply the service brakes, since the hubs will be heated from the brake drums.

CONTROL SYSTEMS

Steering system

During the turn of the steering wheels to the right, to the left until it stops, noise in the hydraulic power steering may occur as a result of the maximum pressure in the hydraulic pump. This noise is a typical sign of the pump working, and it does not influence the efficiency of the steering system.

Maintenance-free tie rod ends are mounted on the vehicle. No adjustment or lubrication of the maintenance-free tie rod ends is needed during the operation. The maintenance-free tied rod ends with gaps need replacement.

Check the total steering wheel backlash at idle running of the engine. The total backlash should not exceed 20°.

If the total backlash is higher than the permissible level, the unit, which gives the increased play, should be detected. Therefore, the following should be checked: proper tightening (see Appendix 2) of the steering box bolts, condition of tie rod joints, tightening of drive shaft joints, gaps in joints and spline coupling of the steering column drive shaft, and gaps in the steering mechanism.

If radial gap in the joint of the steering shaft is detected (axial displacement of the crosspiece in bearings), punch the bearings in yoke eyes, so that the bearing sleeve shall not become deformed.

If gaps in the spline couplings of the steering shaft are detected, the shaft should be repaired or replaced.

The steering mechanism can be used only for a short time, when the hydraulic power steering is out of order as a result of pump damage, hose or pump drive belt failure or when the vehicle is towed as a result of engine stoppage. If the hydraulic power steering system lacks oil, the pump drive belt should be removed, otherwise pump seizure or tearing of belt is possible. Pay special attention to coolant temperature, when the pump drive belt is removed, to avoid engine overheating.

Long-term vehicle operation with non-working hydraulic power steering can lead to the premature wear of the steering system.

Tension of hydraulic power steering pump drive belt see "Engine Cooling System" section.

Replace the belt if damages or excessive stretch is detected.

Hydraulic Power Steering Oil Level Check and Change. To check the oil level in oil tank, the position of the front wheels

must be straight. Pour the oil into the oil tank up to the level of the filling filter screen or no higher than 5 mm. Run the oil beforehand through the filter with the maximum filtration fineness of 40 μm .

Fill the system by the following steps:

1. Disconnect the drag link from the drop arm and lift the front wheels with a jack.

2. Remove the cap from the oil tank, pour the oil until it can be seen over the filter screen (no higher than 5 mm).

3. Do not start the engine, lock the steering wheel or the input shaft of the mechanism lock-to-lock until air bubbles stop coming out of the oil tank. Add some more oil into the tank.

4. Start the engine and add the oil into the tank simultaneously.

Note. If the oil foams abundantly in the tank, which means that air has entered into the system, stop the engine and let the oil settle for at least 20 minutes (until all bubbles come out from the oil). Inspect the connections between the hoses and the hydraulic power steering system aggregates and eliminate the leakage as required.

5. Let the engine run for 15-20 seconds and bleed the hydraulic power steering system to remove residual air from the steering mechanism, by turning the steering wheel lock-to-lock with no stops in the end positions 3 times in each direction.

6. Check the oil level in the tank. The oil should be at the level of the filter screen in the tank.

7. Cover the tank and tighten the cap manually.

8. Connect the drag link, tighten and cotter the ball stud nut.

Maintenance of the control and safety valves of the pump.

If foreign material ingresses into the control and safety valves, wash them. To do this:

1. Unscrew the closing plug 9 (Fig. 9.32), placed over the outlet orifice of the pump.

2. Pull out spring 5 and operating valve 1, and replace the closing plug into its place — it will prevent the oil from draining out.

3. Unscrew safety valve seat 6, pull out ball 4, the guide 3 and spring 2. Pull out ring 8 and filter 7 from the safety valve seat.

4. Wash and air-blow the parts.

5. Reassemble in the reverse sequence. Keep clean during reassembly. In order to keep the adjustment of the safety valve during disassembly and reassembly, do not change the number of adjustment shims 11.

Fig. 9.32. Control and safety valves of the pump:

1 — control valve; 2 — safety valve spring; 3 — guiding safety valve spring guide; 4 — safety valve ball; 5 — valve spring; 6 — safety valve seat; 7 — filter; 8 — ring; 9 — closing plug; 10 — sealing spacer; 11 — shims

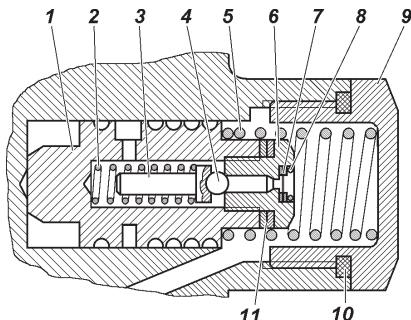

Brake systems

WARNING! *On a vehicle with a diesel engine, after a long parking (over 8 hours), start driving at least in 20...30 seconds after starting the engine, so that the vacuum pump can create a vacuum in the brake booster sufficient for comfortable braking.*

During the idle running of the engine, when the diesel engine runs at the minimal engine speed of the crankshaft lower than allowable (see section "Technical characteristics"), the vacuum brake booster capacity decreases, so regularly check the engine speed of the crankshaft during idle running of the engine.

In case of a frequent depression of the brake pedal, in the motor vehicle with a diesel engine (after the pedal release, it is depressed again, e.g., on a downhill trip), the vacuum pump is not able to create the required vacuum, and as a result braking capacity decreases and it will be necessary to apply increased force to the brake pedal.

WARNING! *Please remember, that a stopped engine and disabled vacuum booster considerably increases the effort necessary for pushing the brake pedal to stop the vehicle.*

WARNING! *If one of the brake system circuits is out of order, brake pedal travel is increased and braking efficiency is decreased. In this case, do not make short-time multiple pedal pushes, instead push the pedal until maximum braking.*

If the brake system does not work properly, it is prohibited to drive the vehicle or to tow it with a tow-rope. In this case, for towing, you should use a wheel-lift device or a flatbed towing service.

WARNING! *Brake disc hardware, tubing T-connector, parking brake drive details, governor drive and the governor itself are fixed with adhesive sealant (with no spring washer) to prevent unscrewing. Add adhesive sealant if you unscrew these bolts and nuts.*

WARNING! Brake fluid is toxic. Keep it in a tightly closed container. While using it, follow these rules:

- avoid any operations resulting in ingress of the fluid into your mouth;
- if the fluid touches your skin, do not let it dry out — wash it off with warm soapy water;
- wash the spilled fluid off with water, and ventilate the room;
- dry out dirty clothing outdoors, before washing.

When depressing a brake pedal (in a stopped vehicle, the engine runs at idle), a slight noise may occur from air intake into the vacuum booster.

The level of brake fluid in tank 3 (Fig. 9.33) can be checked visually by the marks on the tank housing, made of semitransparent plastic. When cap 2 is off and brake linings are new, the fluid level should be up to the "MAX" mark. If the brake hydraulic drive is in good order, reduced level of the tank fluid is connected

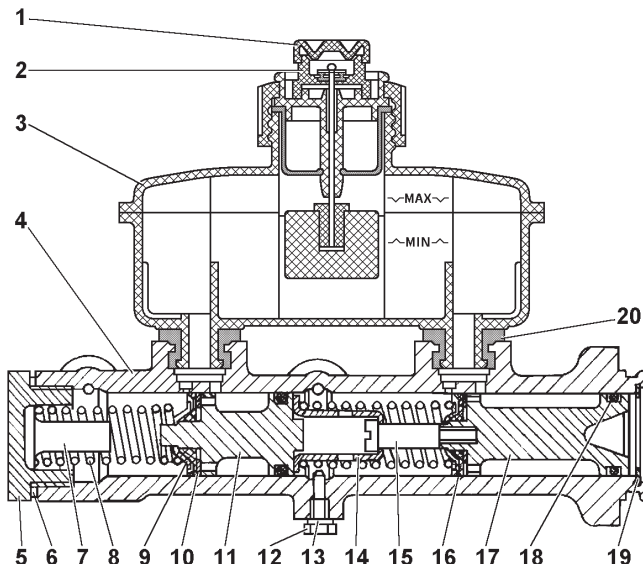

Fig. 9.33. Brake master cylinder:

- 1 — protective cap; 2 — brake fluid emergency level sensor cap; 3 — tank;
- 4 — brake master cylinder housing; 5 — plug; 6, 13 — spacers; 7 — plug liner;
- 8 — spring; 9 — spring seat; 10 — washers; 11, 17 — pistons; 12 — thrust bolt;
- 14 — stop bushing; 15 — lock screw; 16 — sealing collar; 18 — outer collar;
- 19 — snap ring; 20 — connecting bushing

with the wear of linings of brakes pads. Reducing the fluid level to "MIN" mark indicates that the linings of brake pads have had maximum wear. In this case, check the condition of the linings, no need to add fluid into the tank, as the installation of new linings will bring the fluid level in the tank up to the normal.

Brake fluid warning light comes on when the fluid level falls lower than the MIN mark, which indicates that, if brake pad linings are new or partially worn, the system is not airtight or the fluid is leaking. In this case, add fluid only after all leakages are eliminated.

Check the fluid level in the tank simultaneously with the alarm level sensor by pushing the central part of protective cap 1 (if the ignition is switched on, the warning light should appear on the dashboard).

Check the hoses of the brakes. If cracks have appeared on the outer side of the hoses, replace them.

Front disc brakes. To inspect brake shoes 2 (Fig. 9.34), place the vehicle on a level ground and set the parking brake. Inspect the shoes through the window in caliper 4. If the linings wear to the thickness of 1.5–2.0 mm, replace the shoes on both front brakes.

If brake shoes with audio signals of the wear are installed on the motor vehicle, change the shoes if clanking (tinkling) occurs, which indicates the shoes are worn down.

Make sure you properly install such shoes. The shoes with audio signals of the wear are not interchangeable — the left for right brakes. Install such shoes from the piston side, so that the wear signal is in the upper part of the shoe (brake). Install the shoes without signals to the outer parts of both brakes.

To replace the brake shoes, unscrew bolts 16, remove carrier 18 and spring 1.

Check the brake disc. If its surface has deep notches and burrs, remove it, clean and grind. When the disc wears to the thickness of 20.4 mm, replace it.

Check protective caps 5 and boots 8 for damage and proper installation in seats, replace them, if necessary.

Check the outer surface of bushings 10 in the area of boots 8 for grease and lubricate them with UNIOL 2M/1 TU 38.5901243-92 grease, as required.

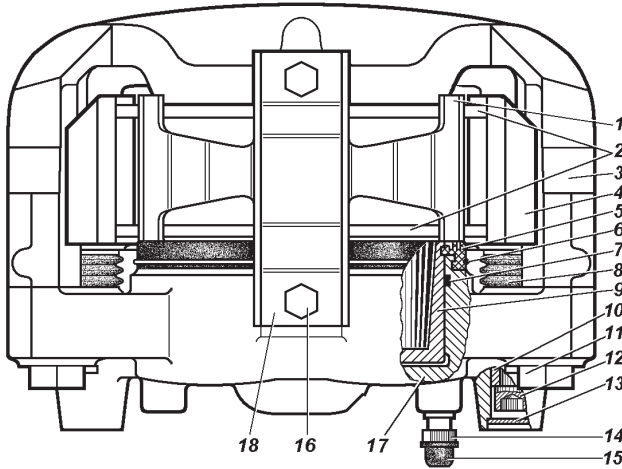

Fig. 9.34 Front disc brakes:

1 — spring; 2 — shoes; 3 — clip; 4 — caliper; 5 — protective cap; 6 — snap ring; 7 — O-ring; 8 — protective boot; 9 — piston; 10 — bushing; 11 — bolt; 12 — screw; 13 — plug; 14 — proportioning valve; 15 — cap; 16 — spring carrier bolts; 17 — crankcase; 18 — spring carrier

Move clip 3 until pistons 9 rest in the inner surface of crankcase 17. Bypass valve 14 can be opened to ease the fluid displacement from crankcase 17. Close valve 14 as soon as pistons 9 completely sink into the crankcase. Before moving clip 3, remove the cap of the master cylinder tank and do not let the fluid overflow while moving the clip.

It is prohibited to recess the pistons with a tire iron as it can deform guide bushings 10 and disable clip 3.

Replace worn brake shoes from both sides of the front axle shaft. To place the shoes against the disc, press the brake pedal 2-3 times.

Install spring 1, spring carrier 18 and screw bolts 16.

During further operation, the necessary gap between the brake shoes and the brake disc is supported automatically.

Rear drum brakes (Fig. 9.35). Remove brake drums periodically and clean the brake parts from dust and dirt. The frequency depends on vehicle operation conditions. Clean the drums more frequently in the summer and when driving on dirty roads, and less frequently in the winter.

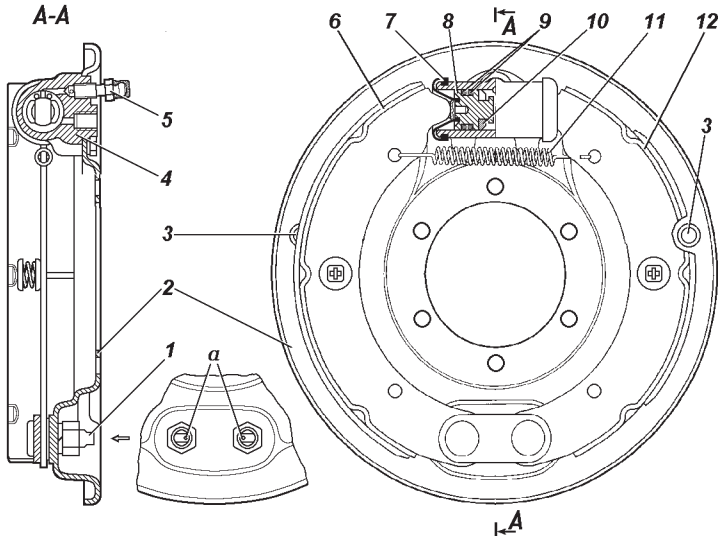

Fig. 9.35. Rear wheel brake:

a — anchor stud marks;
 1 — anchor studs; 2 — shield; 3 — orifices for visual inspection of brake linings; 4 — wheel brake cylinder; 5 — bypass valve; 6,12 — brake shoes; 7 — protective cap; 8 — piston; 9 — O-rings; 10 — snap ring; 11 — release spring

After the drum is removed, check the safe fastening of the wheel cylinders to the shields. Pay attention to the condition of the wheel cylinders, protective caps, the wear of the frictional plates, and the condition of the brake drum.

Protective caps must be tightly installed in the piston and cylinder seats, and should not be damaged.

If the drum working surface has deep notches and burrs or uneven wear, re-bore the drums from the central orifice. The maximum permissible diameter of the working re-bored brake drum is 281 mm.

It is not recommended to change the brake drums between the hubs, as the working surfaces of the drums will wobble more.

The gap between the shoes and the drum is restored automatically as the linings wear.

Check the wear of linings through the orifices in the shields. Unplug the orifices, inspect the linings (the thickness of the linings should not be less than 2.5 mm), and re-plug the orifices back.

Replace the linings in case of their excessive wear (the rivets are sunk less than 0.5 mm).

When replacing worn shoes or liners, move the piston with the thrust ring deep into the cylinder for free mounting on the drum to the shoes. After reassembly, push the brake pedal 2-3 times to install the pistons into the working position.

Do not press the brake pedal when the brake drum or the leading shoes are removed, as the compressed fluid will press the pistons out of the wheel cylinders and the fluid will escape.

During each drum removal, grind the lip on the edge of the friction surface, which appears from drum wear, to ease the next removals of the drum.

Tighten the bolts of brake shields when the hubs are removed.

Proportioning valve (Fig.9.36). During maintenance, check the function of the proportioning valve. Clean it from the dirt and check the safety of its fastening. Visually inspect that the proportioning valve and its parts have no damage, there is no leakage of the brake fluid and no backlashes in the pillar coupling with the resilient lever and the real axle bracket.

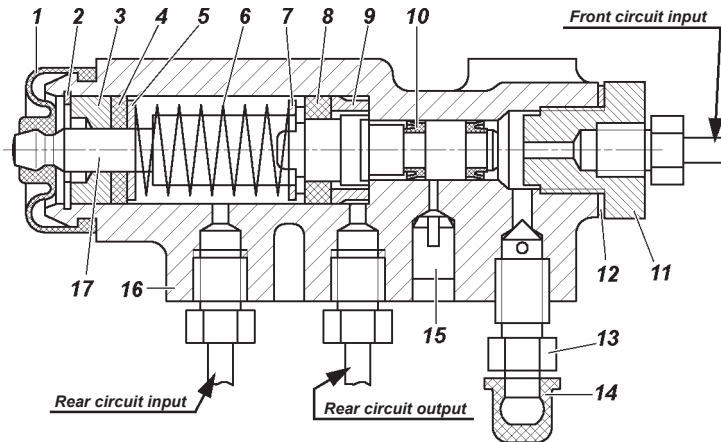

Fig. 9.36. Proportioning valve:

1 — protective boot; 2 — snap ring; 3 — bushing; 4 — piston O-ring; 5, 7 — piston spring supporting washer; 6 — piston spring; 8 — weatherstrip; 9 — housing bushing; 10 — collar; 11 — lock; 12 — lock spacer; 13 — bypass valve; 14 — cap; 15 — plug; 16 — housing; 17 — piston

When pressing the brake pedal, the proportioning valve piston should move out from the housing by 1.7-2.3 mm. If the piston has no stroke, as well as a poor or excessive stroke, the valve or its drive have malfunctions.

When inspecting the hydraulic drive, pay attention to the position of gauge plug 15 and to the absence of brake fluid leaking from it. The plug should normally be sunk into the housing orifice of the valve, up to the stop. If the plug comes out or the brake fluid leaks, the valve must be repaired or replaced.

During the operation and replacement of back leaf-springs, adjust the force of flexible arm 5 (Fig. 9.37) to the valve piston. For adjustment do the following:

1. Place the vehicle with its curb weight on an even level ground.
2. Loosen the lock-nut of adjusting bolt 4 and unscrew the bolt for 2-3 turns.
3. Tighten bolt 4 (see Fig. 9.37) until it touches the regulator piston end 17 (see Fig. 9.36) by screwing the adjusting bolt for 1...11/3 turn (6-8 flats of the bolt head).
4. Check the stroke of the valve piston (see above).
5. Check adjustment correctness during motion of the vehicle.

While going on a straight level road with a dry surface, brake the vehicle until the wheels lock. If the valve is in order and drive adjustment was done correctly, the front wheels should be blocked slightly earlier than the rear ones. If the rear wheels are blocked earlier, unscrew bolt 4 (see Fig. 9.37) by 1-2 flats of the bolt head and check the brakes in motion again.

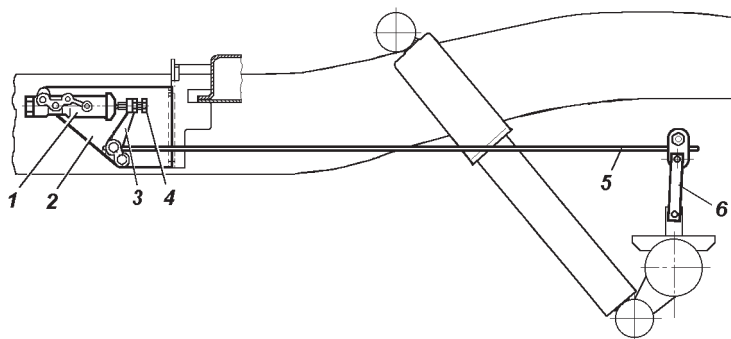

Fig. 9.37. Proportioning valve drive:

1 — Proportioning valve; 2 — bracket (base); 3 — drive lever; 4 — adjusting bolt; 5 — flexible lever; 6 — lever pillar

Change the brake fluid regularly for proper work of the brakes. The recurrence of the change is indicated in the service book. Drain old fluid via the bypass valves of the wheel cylinders and proportioning valve, and then replace it with a new one.

Fill the brake system as follows:

1. Check all couplings of the hydraulic drive of the brakes for leakages and the condition of the flexible rubber pipes.
2. Clean the bypass valves and the protective caps of the wheel cylinders from dust and dirt.
3. Clean the tank of the master cylinder from dust and dirt around the cap and uncover it. Fill the tank with brake fluid up to the MAX mark.
4. Press the brake pedal several times to eliminate effect of the vacuum formation in the brake booster.
5. Bleed the brake system.

Bleed the system as follows:

1. Bleed successively the chambers of the right and left rear wheel brake cylinders, the front circuit of the proportioning valve and then the right and left front wheel brake cylinders.
2. Remove the cap from the bypass valve of the wheel cylinder or from the proportioning valve and place a special rubber hose (approx. 400 mm long) on the valve.

Drop the other end of the hose into a transparent vessel with no less than 0.5 l capacity, which is half-filled with brake fluid.

3. Press the brake pedal 3-5 times abruptly, hold it in the extreme position and simultaneously unscrew the bypass valve for 1/2-3/4 of a turn, in order to release the fluid portion from the system to a vessel. After the pedal goes forward up to the stop, screw the valve. Repeat the operation until bubbles stop coming out from the hose, dropped into the vessel with brake fluid.
4. When the bleeding is over, press the pedal and hold it in the extreme position, screw the bypass valve and remove the hose. Dry the valve head and put on the protective cap.
5. Add brake fluid up to the MAX mark into the master cylinder tank.

Cover the tank carefully to avoid breaking the cap.

While bleeding, add the fluid to the master cylinder tank in time and do not let the fluid level decrease lower than 2/3 of the tank volume. Hold the hose end dropped into the fluid.

Check the brake system when the vehicle is in motion. If the working brakes and their drives are adjusted correctly and the

brake system is bled correctly, full braking occurs within 1/2-2/3 of the pedal travel.

It is forbidden to add the brake fluid collected in the vessel, after bleeding, to the master cylinder tank.

Brake pedal free travel. As required by turning adjusting screw 7 (Fig. 9.38), choose the gap in the coupling: the yoke of the vacuum booster push rod — brake gear lever. Pedal free travel should be 5-8 mm. After adjusting, tighten the screw nut 8 with the torque of 14-18 N · m (1.4-1.8 kgf · m).

Adjust switch 6 with nuts 9, maintaining the gap of 0.5 mm, which is indicated in the figure. After adjusting, tighten the nuts with the torque of 4-6 N · m (0.4-0,6 kgf · m).

Parking brake system

Clean the brake pads from dust and dirt, and sand them if they became greasy. Replace greasy linings or keep them in petrol for 20-30 min and grind them with sand paper or wire brush.

Replace the linings in case of their excessive wear (the rivets are sunk less than 0.5 mm). Grind the linings on new pads, so that their diameter would be 0.2-0.4 mm less than the brake drum diameter.

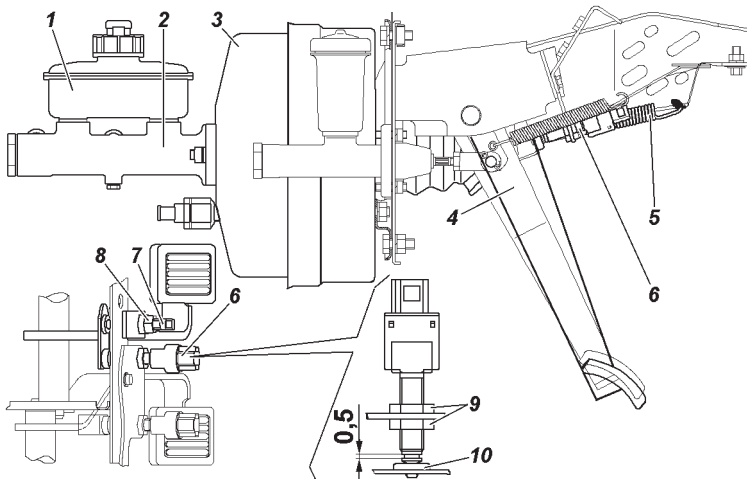

Fig. 9.38. Master cylinder drive:

1 — tank; 2 — brake master cylinder housing; 3 — vacuum booster; 4 — brake pedal; 5 — release spring; 6 — brake signal switch; 7 — adjusting screw; 8, 9 — nuts; 10 — buffer.

Despite the labyrinth seal of the release and adjusting mechanisms, they gradually collect dirt, therefore, dismantle and clean the mechanisms (especially the release mechanism), adding new grease. Do not let the grease contact the drum and the linings.

Adjust the brake when the brake lever travel reaches more than the half of its maximum travel, and when the braking effect is insufficient.

Adjust the gaps between the pads and the drums as follows:

1. Shift the transfer case lever into neutral position.
2. Lower parking brake lever 1 (fig. 9.39) into its extreme position.
3. Jack up the vehicle from the rear wheel side.
4. Tighten adjusting screw 10 so that the brake drum cannot be turned by hand.
5. Loosen adjusting screw by 4-6 clicks (1/3-1/2 of the torque), so that the drum revolves freely by hand.

Adjust the length of the brake drive rod as follows:

1. Lower lever 1 into its extreme position.
2. Tighten screw 10 so that the brake drum cannot be turned by hand;
2. Unscrew lock-nut 16 of adjusting yoke 17, remove the snap pin and take out the stud, which connects the yoke with drive lever 18.
3. Match the orifices in the yoke and lever 18 by rotating yoke 17. You should choose gaps in the release mechanism and in the drive by moving lever end 18 with the orifice and rod 15 to each other.
4. Install the stud, cotter it and tighten the lock-nut ;
5. Loosen adjusting screw 10 by 4-6 clicks, so that the brake drum revolves freely.

If adjusted correctly, the vehicle should brake when the lever pawl is installed into the 4th or 6th sector slot from the bottom (4-6 clicks).

Check the wire cable tension by moving the lower wire cable tip in the bracket within the length limit of the tip. If the length is not enough, adjust the wire cable tension by changing the rod length. Tighten the nuts after the adjustment.

It is forbidden to check the parking brake system at start or during motion. The check should be done only on a slope.

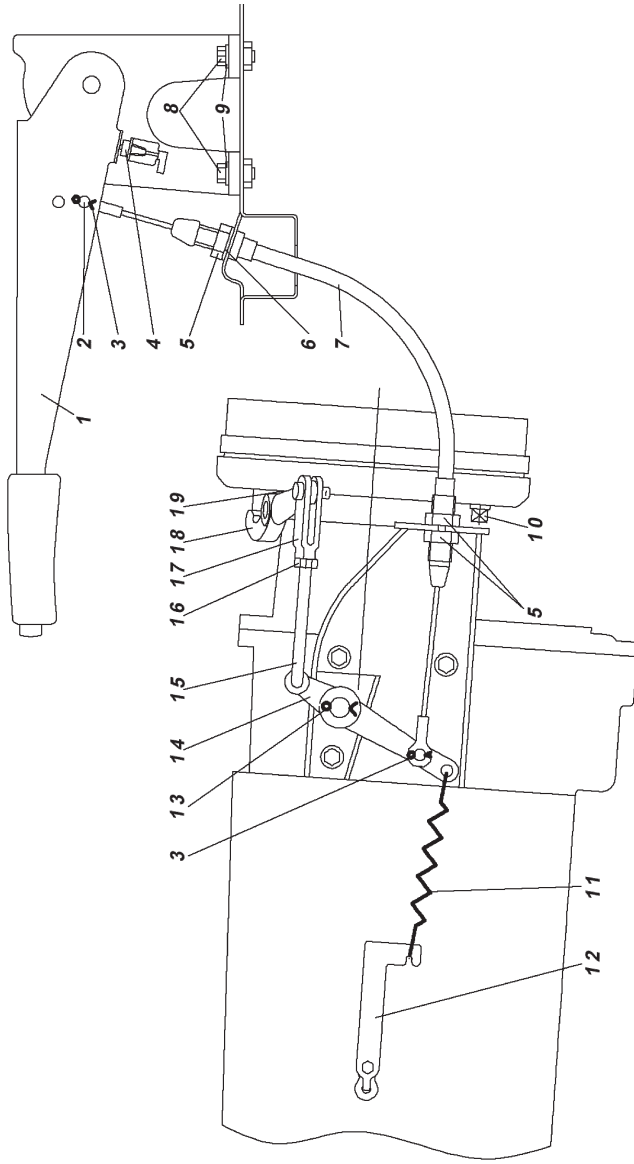

Fig. 9.39. Parking brake mechanism drive.

- 1 — drive lever with sector; 2 — stud; 3, 13 — snap pins; 4 — parking brake signal switch; 5 — nuts; 6 — washers; 7 — drive wire cable; 8 — bolts; 9 — spring washers; 10 — adjusting screw; 11 — release spring; 12 — spring bracket; 14 — idler lever; 15 — drive rod; 16 — lock-nut ; 17 — adjusting yoke; 18 — drive lever; 19 — housing of release mechanism balls

ELECTRIC EQUIPMENT

Alternator

WARNING! *Even short-time engine operation with the battery disconnected can lead to damage of alternator diodes.*

Removing the alternator for maintenance, switch off the battery by disconnecting the wire from its negative terminal.

Keep the alternator clean. Air bleed it to remove dust, check the brush assembly condition. Replace worn-out brushes.

During operation of the alternator, the alternator drive belt tension should be monitored.

Check alternator operations with a voltmeter reading and the battery discharge dashboard warning lamp.

In case of a malfunction, check the alternator operations at a service station.

Battery

The battery is installed on a bracket under the engine hood of the vehicle.

If during the proper operation of the vehicle, the battery is gradually discharged or overcharged by the alternator, and the electrolyte starts boiling, check the alternator operations.

Keep the battery clean and charged, protect the battery clips and the cable terminals from oxidation.

Periodically clean vent orifices in the plugs, check electrolyte level and add distilled water as required.

Before operation, correct electrolyte density, corresponding to the climate area of the vehicle operation (see the Battery Operating Manual).

At the factory, the vehicle is supplied with a battery with density of 1.28 g/cm³.

Do not allow long battery discharge by a large current power (when starting a cold engine in winter time).

Thoroughly prepare the engine for starting and turn on the starter only for a short period of time — no more than 15 seconds.

Operate the battery in accordance with the Battery Operating Manual.

During long parking of the vehicle, turn off the battery by disconnecting the wire from the negative terminal.

Starter

Removing the starter for maintenance, switch off the storage battery by disconnecting the wire from its negative terminal.

Periodically do the following:

- check the bolts, which mount the starter to the engine, for tightness, and clean them;
- check starter terminal ends for cleanliness and mounting security

Disconnect battery when removing the starter for maintenance.

On the removed starter:

- check the relay switch terminals and the working surface of the electric terminals;
- check the starter drive — gear, lever and spring;
- clean the rubbing parts from dirt and lubricate them with "Litol-24" grease.

Starter drive should move freely with no jamming at the shaft splines, and it should come back to the source position by the action of the return spring. The anchor should not rotate when the drive gear rotates in the working direction. In case of reverse rotation, the gear should revolve with the shaft. In turning the shaft by hand, check the ease of rotor rotation in bearings with lifted brushes.

Warning: 1. The sleeve of starter travel can fail, if the starter is on after the engine begins working.

2. Do not wash the starter caps and the drive with gasoline or kerosene to avoid the removal of grease from bronze graphite cellular plain bearings.

WARNING! *It is forbidden to move the vehicle with the starter. The starter should work no more than 10 seconds uninterruptedly. Turn on the starter again, after at least a 1 minute pause, no more than 3 times in a row. If the engine cannot be started, detect and eliminate the malfunction.*

Lighting System, Light and Audio Alarm

Despite the good sealing, dust may penetrate into the sealed beam unit. Do not disassemble the sealed beam unit, wash it with clean water and a cotton pad through the unit orifice, and further dry the unit.

To replace the bulb in the headlamp, loosen three screws 3 (Fig. 9.40) and take out inner molding 2 with sealed beam unit 1.

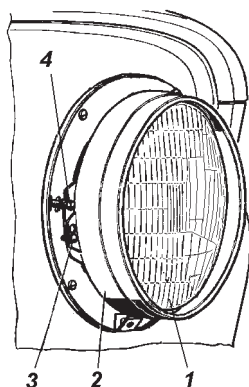

Fig. 9.40. Headlamp:
 1 — Sealed beam unit; 2 — inner molding;
 3 — screws; 4 — adjusting screws

Perform the adjustment of headlamps in the following sequence:

1. Park the vehicle with full fuel tank, its curb weight, normal tire pressure and loaded driver's seat of 750 N (75 kgf), on an even level ground 5 meters away from a screen with special markings (Fig. 9.41).

2. Place the headlamps hydrocorrector handle on the instrument panel in a position corresponding to a one-driver vehicle load.

3. Switch on low beams and, covering each headlamp in turn, rotate adjusting screws so that the cutoff line from E and E' points on the left coincides with line 1 and on the right coincides with lines 2 and 2' for the left and right headlamps respectively. The breaking points of the cutoff line should coincide with E and E' points.

If it is not possible to adjust the headlamps, check the function of the headlamp corrector.

The corrector is not repairable. In case of damage, replace the corrector.

Adjust the front fog lights so that the area of concentrated light on the wall or the aiming screen is located as indicated on Fig. 9.42. To replace the fog light bulb, remove the cover of the bulb holder by turning it counterclockwise and remove it.

Front, rear headlamps, backing lamp, side repeaters of turn signal lights, rear fog lamp. To change the bulbs, loosen screws that fasten the lens and remove it.

License plate lamps. To change the bulbs, loosen the screw that fastens the cap, remove the cap and the lens.

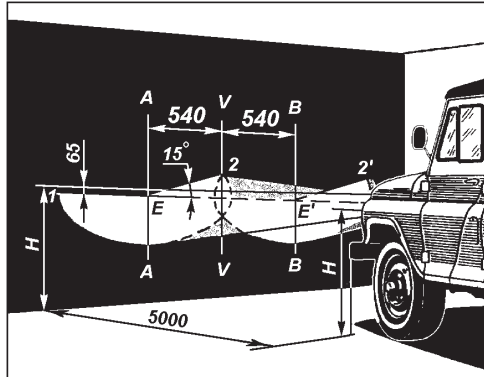

Fig. 9.41. Screen markings for headlamps adjustment:
 H — distance between the headlamp center and the ground level; V-V — vehicle's longitudinal axle shaft projection; A-A, B-B — axle shafts of headlamp centers

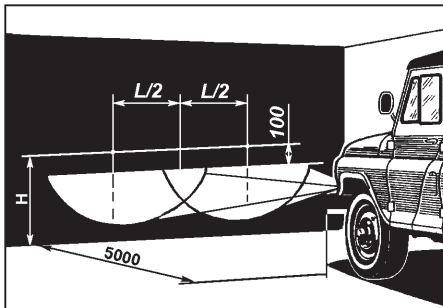

Fig. 9.42. Screen markings for front fog lights adjustment:
 H — distance from the front fog lights center to the ground level;
 L — distance between the front fog lights centers

Additional brake alarm lamp. To change the bulbs, loosen two screws and remove the rear cap of the lamp.

Maintenance of the horn amounts to periodic checking it for fastening, tightening of wire clamps, cleaning it from dust and dirt and also checking the sound intensity and adjusting as required.

Adjust the horn at the service station.

Relays and fuses

Two fuse boxes (Fig. 9.43) with thirteen fusible links each are placed under the instrument panel to the left of the steering column. The bracket with the relay is placed on the front left side panel from the driver's side (Fig. 9.44).

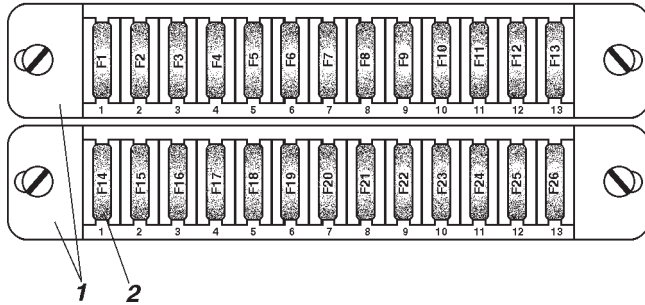

Fig. 9.43. Fuse box:

1 — fuse box housing; 2 -F1-F26 — fuses (see the table)

On UAZ-315148 vehicles, the relay and fuse box are installed on the right, under the vehicle's hood (Fig. 9.45).

On UAZ-315195 vehicle, a fusible switch box with two fuses is installed (Fig. 9.46). The fusible switch box is placed on the front shield, under the hood.

Before replacing a burnt out fuse, find out the reason for its failure and eliminate it.

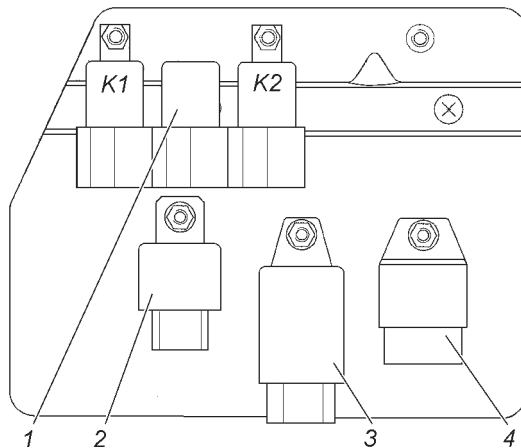

Fig. 9.44. Bracket with the relay:

K1 — low beam relay; K2 — upper beam relay; 1 — turn signal interrupter; 2 — control unit of the seat belt alarm; 3 — rear fog lights relay; 4 — windshield wiper interrupter

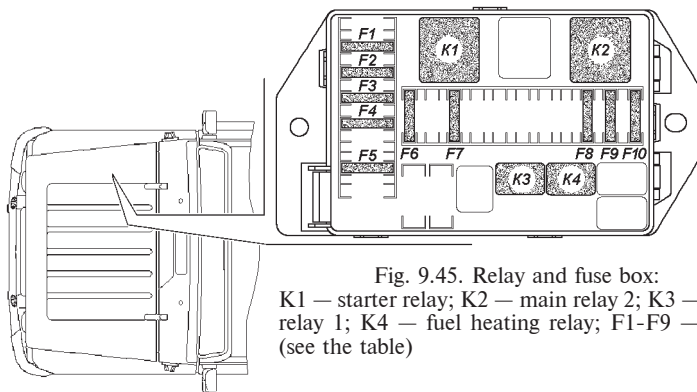

Fig. 9.45. Relay and fuse box:
 K1 — starter relay; K2 — main relay 2; K3 — main relay 1; K4 — fuel heating relay; F1-F9 — fuses (see the table)

When operating the vehicle and when checking the electric equipment circuit, it is not permitted to use fuses not stipulated by the design (see the table), and also it is not allowed short circuit to the ground wire (to check the function of the circuits "for spark").

Instrumentation and warning alarms

Periodically check the mounting of the devices, safety of their contact couplings, and clean them from dirt and dust.

When removing electric sensors, isolate the wires to avoid a short circuit. Use a hex socket wrench or a box wrench to remove the temperature sensor and the coolant emergency temperature sensor, without damaging their housings.

Check the fluid level in the cooling system of the radiator. If the fluid level is low, the sensor may fail.

Once a year, check the accuracy of the coolant sensor reading. For this, immerse the sensor in hot water after the hot water temperature is measured by a control thermometer.

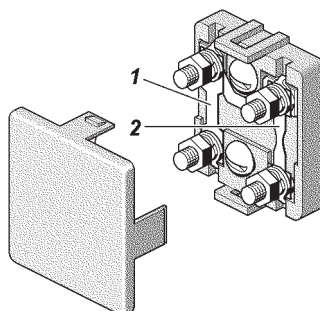

Fig. 9.46. Power fuse box:
 1 — 2 — fuses (see the table)

Circuits protected by fuses

Designation	Current, A	Protected chains
Fuse box (Fig. 9.43)		
		Upper box
F1	25	Reserve
F2	5	Sidelights (right side)
F3	7.5	Headlight — low beam (right side)
F4	10	Headlight — upper beam (right side)
F5	7.5	Front fog light (right side)
F6	5	Fuse box lighting lamp, socket of the portable lamp
F7	7.5	Brake lamps
F8	10	Turn signals in the emergency mode
F9	20	Audio signal
F10	7.5	License plate lamps, instruments, switches illumination
F11	15	Cigarette lighter
F12	5	Rear fog light
F13	10	Reserve (radio equipment)
		Lower box
F14	25	Reserve
F15	5	Sidelights (left side)
F16	7.5	Headlight — low beam (left side)
F17	10	Headlight — upper beam (left side), upper beam warning lamp
F18	7.5	Front fog light (left side)
F19	5	Backing up lamp
F20	7.5	Turn signals in the maneuver regime
F21	10	Heater
F22	20	Electromotor of windshield wiper, windshield washer fluid
F23	7.5	Cabin lighting lamps, engine compartment dome lamp
F24	15	Reserve
F25	5	Instrumentation and alarms
F26	10	Additional pump of heating system (UAZ-315148)
Relays and fuses box (Fig. 9.45)		
F1	30	Onboard power supply
F2	30	Onboard power supply
F3	25	Fuel heating relay
F4	5	Diagnostics
F5	20	Starter motor relay
F6	10	Total air flow sensor
F7	5	Control module
F8	15	Main relay 1
F9	10	Main relay 2
F10	25	Main relay 2
Power fuse box (Fig. 9.46)		
1	40	Outdoor lighting
2	90	Ignition switch terminal "30"

Once a year, check the accuracy of oil pressure switch and emergency oil pressure control lamp switch with the control oil pressure indicator.

VEHICLE BODY

To take care of external appearance of the vehicle, maintain regularly the varnish coating of the vehicle body. Do not wipe dust and dirt with a dry cloth.

Wash the vehicle body with small pressure water jet and soft rags.

When washing the vehicle body using such unit as the "Karcher", some water can ingress into the cabin, which is not a defect.

Wipe the washed vehicle body surfaces dry, so as not to let the stains occur in summer, and in winter, when the water drops freeze, cracks may occur on the coated surface. Do not use soda or alkaline solutions, because the varnish coating could fade. Avoid exposing the vehicle to sunlight for a long time to avoid damage of the rubber of the wheels and the rubber seals.

When washing the vehicle body using such unit as the "Karcher", choose regimes "blade", "fan" or similar. It is not recommended to use the regime "jet" for washing doors and windows to avoid forcing out the rubber seals and ingressing water into the cabin.

To take care of the vehicle body coatings, use prophylactic polishing liquids: auto emulsion, polish (spray), wax AB-70 (for vehicles), etc. To restore shine of a faded coated surface of the vehicle body, apply purifying-polishing liquids.

During the operation of the vehicle, periodically treat the vehicle body surfaces, especially enclosed spaces, with corrosion-preventive compounds such as "Mobil", "Tectil", etc. to prevent the premature corrosion of the vehicle body. Carry out the treatment of the enclosed spaces of the vehicle body through special orifices in the floor panels and cross members, which are closed by rubber plugs.

As required, recover the vehicle body floor, by coating it with bituminous cement, spreading it using a special brush or spray.

Periodically lubricate mechanisms and parts of vehicle body fittings.

LUBRICATION OF THE VEHICLE

Adherence to the instructions of this manual and the service book on lubrication of the vehicle is imperative. The grease brands and types are indicated in the Lubrication and Special Liquids table (see Appendix 3). It is not allowed to use oils and greases not indicated in the table, or to use oils and greases with the expired date either.

The description of the lubrication of the units and changing the grease is found in the corresponding sections of the Manual.

Within 24 hours after overcoming a ford, check the oil condition in all the aggregates. If water is detected in the oil, change the oil in that aggregate, and lubricate all the grease pumps of the chassis until fresh grease squeezes out of them.

In the process of lubrication, adhere to the following rules:

1. Drain oil from the engine and the transmission aggregates immediately after the vehicle stops and the aggregates are hot.

2. Thoroughly remove dirt from the grease pumps and plugs before lubricating to avoid an ingress of dirt into the vehicle mechanisms.

3. Upon lubrication, remove the squeezed out or leaked lubricant from all parts.

4. Before filling the housings with fresh oil, wash them if the wasted oil, drained from the housings of the engine and the transmission aggregates, is contaminated or metal particles are detected in it.

5. Mixing (adding) of engine oils of different brands and different manufacturers is not allowed.

When changing the oil brand or manufacturer, flush the engine lubrication system.

6. Mixing the grease Litol-24 with the substitute grease Lita is allowed in any proportions. When using other substitutes, flush the unit with kerosene.

7. Mixing the brake fluids "Rosa", "Rosa-3", "RosDot", "Tom", "Rosa Dot-4" is allowed in any proportions.

Chapter 10. SPECIAL TOOLS AND APPLIANCES

Each new vehicle, delivered from the manufacturing plant, is equipped with a set of tools and appliances according to the list applicable to the vehicle.

Jack (Fig. 10.1 or 10.2) is designed to jack up the vehicle wheels during its maintenance or repair. The jack load-lifting capacity is 2 tons. The maximum height of lifting shown on Fig. 10.1 — 240 mm, on Fig. 10.2 — 295 mm.

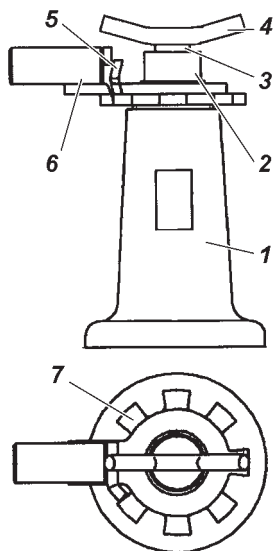
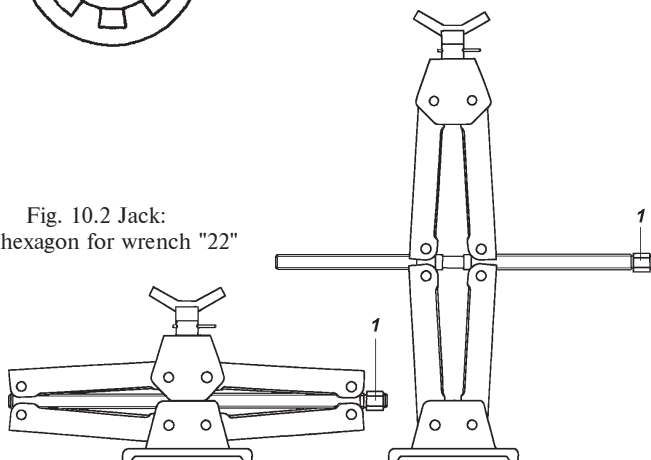

Fig. 10.1 Jack:

- 1 — housing; 2 — external screw;
- 3 — internal screw; 4 — head;
- 5 — pawl; 6 — handle; 7 — ratchet

Fig. 10.2 Jack:
1 — hexagon for wrench "22"



For jacking up the wheel with jack shown on Fig. 10.1, proceed as follows:

1. Brake the vehicle with the parking brake, shift into the first or reverse gear of the gearbox, making sure that the transfer case gear lever is not in the neutral position. As required, put wedges under the wheel, which is opposite to the jacked up wheel.

2. Install the jack on a level ground under the axle shaft sleeve.

3. Unscrew the jack's internal screw 3 as high as the clearance between the axle shaft sleeve and the ground permits.

4. Throw latch 5 over the jack to the left-hand side, relative to the jack handle 6, so that latch projection enters the tooth space of the ratchet wheel 7.

5. By pumping the tire iron inserted in the orifice of the jack handle, lift the vehicle wheel to the required height.

6. For jacking down the wheel, throw the latch over the jack to the right-hand side and by pumping the tire iron, deepen the jack screws into the housing 1. After work is over, turn in the outer 2 and inner 3 jack screws into the housing up to the stop.

For jacking up the wheel with jack as shown on Fig. 10.2, proceed as follows:

1. Brake the vehicle with the parking brake, shift into the first or reverse gear of the gearbox, making sure that the transfer case gear lever is not in the neutral position. As required, put wedges under the wheel, which is opposite to the jacked up wheel.

2. Install the jack on a level ground under the axle shaft sleeve.

3. Lift the vehicle wheel to the required height, rotating jack hexagon 1 clockwise with the help of the wrench for the wheel nuts.

4. To jack down the wheel, rotate hexagon 1 with the wrench counterclockwise. After work is over, lay down the jack, completely rotating the hexagon with the wrench.

Maintenance of jacks amounts to periodically cleaning it of mud and lubricating its threaded parts.

Watch the condition of jack riveting couplings, its screws and rods. Strain or damage of the screws and rods, loosening of the riveting couplings is not allowed. Replace the jack in these cases.

Chapter 11. PRESERVATION

If the vehicle is to be removed from operation for a prolonged period of time — more than 1.5 months, it should be subjected to preservation procedures, for which purpose do the following:

1. Carry out the scheduled maintenance.
2. Wash the vehicle and wipe it dry. Remove corrosion and touch up the paintwork wherever damaged.
3. To protect the engine cylinders against corrosion, pour 30-50 g of hot engine oil used for the engine (except for engine ZMZ-51432) into the cylinders. To ensure uniform spreading of oil throughout the entire surface of the cylinders, rotate the engine crankshaft by approximately 15 revolutions.
4. Clean all wires from dirt and wipe dry.
5. Use the preservative lubricant PVK (if not available, use petroleum jelly) for all unpainted external metal surfaces of the vehicle and all unpainted parts of hinged couplings (hinges and door locks, parking brake drive rods, control rods of the carburetor, towing gear and other units, and also spark plugs).
6. Lubricate the springs with a graphite lubricant.
7. Check, clean the tools, accessories and spare parts set and wrap them with oiled paper or with cloth.
8. Seal the windows from outside with light-tight paper (cloth) or shut with shields.
9. Remove the wheels from the vehicle, clean the wheel discs from dirt and touch up the areas with damaged paint. Clean, wash and wipe dry the tires, bring the tire inflation pressure to normal.
10. As required, flush out the fuel tanks and fill them with fuel.
11. Prepare the battery for storage, as specified in the maintenance manual for vehicle lead batteries.
12. Seal the slit of the air cleaner and the muffler exhaust pipe with oily paper.
13. Loosen the tension of the fan driving belt and steering gear pump, of the alternator and the water pump.
14. Drain the coolant from the cooling system, heater radiator and the fluid from the windshield washer reservoir.

15. Seal the housings of the gearbox, transfer box, front and rear axles by wrapping the safety valves of these aggregates with the insulating tape.

16. Seal the clearance between the backing plates and the brake drums with oiled paper.

17. Protect the tires and other rubber parts from direct sunlight.

18. Put metal or wooden props under the axles so that the wheels are raised above the floor or the ground.

Unload the leaf-springs and springs, by putting wooden struts between the frame and the axles.

The preserved vehicle should be located in a clean ventilated room with a relative humidity of 40-70 % and temperature not less than +5°C.

Do not keep chemically aggressive substances (acids, alkali, etc.) in the same room with the vehicle.

Maintenance of a stored vehicle

Carry out the maintenance of the vehicle every two months. Proceed as follows:

1. Carefully inspect the vehicle from the outside.

2. Unscrew the spark plugs (except for engine ZMZ-51432) and shift in the first gear of the gearbox and the low gear of the transfer case, then turn the crankshaft of the engine by approximately 15 revolutions. Once a year, before turning the crankshaft, lubricate the engine cylinders with 30-50 g of engine oil.

3. Clean and paint corroded areas if any are detected.

4. Rotate the steering wheel from lock-to-lock position 2-3 times.

5. Check the service and parking brakes, the clutch, throttle drive, and headlamp switches.

6. Check the working fluid level in the reservoirs of the brake master cylinder. As required, top up to normal.

7. Check electrical equipment instruments.

8. Check the tools and accessories. Wipe and lubricate them as required.

9. Check the condition of tires and other rubber parts.

10. Eliminate any detected defects during inspection.

De-preservation

1. Remove the preservative lubricant from the parts by washing them with kerosene or clear gasoline. Remove lubricant from areas, which may come in contact with rubber parts or painted surfaces. Thoroughly wash the spark plugs in clear gasoline.
2. Carry out daily maintenance of the vehicle.
3. Check the oil level in the engine housing. Drain any excessive oil.
4. Before starting the engine, lubricate each cylinder with 30-50 g of engine oil and turn the crankshaft by 10-15 revolutions.

Chapter 12. TRANSPORTATION

Vehicles can be transported by railway, water or air transport.

When transporting the vehicles by water or air transport, fasten them in accordance with the ship scheme or air transport scheme. Use appliances, which would not damage the parts and the paint of the vehicle.

The loading and unloading of the vehicles should be carried out by a crane with special grips.

On all transports, the vehicles should be located so that the distance between the vehicles (extreme points) on the engine cooling radiator side would equal to 50-100 mm, and on the other sides not less than 100 mm. When transporting, the parking brake should be on, the engine shut down, the gearbox lever should be in the position of the first gear, and the battery should be switched off (wire disconnected from the negative terminal).

Before transporting by air, the fuel tanks should be filled with fuel to not more than 75 % of their capacity.

The vehicle should be driven into an airplane with the first gear of the gearbox and with the lower range of the transfer case or in reverse.

Chapter 13. SCRAPPING

The vehicle is scrapped in accordance with local regulations, rules and methods.

VEHICLE LAMPS

Lamps	Lamp Type	Power, W
Headlamps: upper and lower beam	AKG12-60+55-1(H4)	60x55
Front lamps:		
of side lights	A12-5	5
turn signals	A 12-21-3	21
Rear lamps:		
of turn signals	A12-21-3	21
side lights	A-12-5	5
brake signal	A-12-21-3	21
Side turn signal repeaters	A 12-5	5
Backing up lamps	A 12-21-3	21
License plate lamps	A 12-5	5
Additional stop-light lamp	A 12-5-2	5
Underhood lighting lamp	A12-21-3	21
Cabin lighting dome lamp	A 12-10	10
Rear fog lamp	A12-21-3	21
Front fog lights	AKG 12-55 (H1)	55
Portable lamp	A12-21-3	21
Instruments and reserve fuel level lighting	AMN12-3-1	3
Upper beam warning lamp	A12-1.2	1.2
Oil emergency pressure warning lamp	A12-1.2	1.2
Coolant emergency overheating warning lamp	A12-1.2	1.2
Turn signal warning lamp	A12-1.2	1.2
Brake emergency condition warning lamp	A12-1.2	1.2
Parking brake warning lamp	A12-1.2	1.2
Emergency flasher warning lamp	A12-1.1	1.1
Battery discharge warning lamp	A12-1.2	1.2
Fuel injection engine malfunction warning lamp	A12-1.2	1.2

TIGHTENING TORQUE OF MAIN THREADED COUPLINGS, kgf • m

Fittings of steel fuel lines	2.5-3.0
Clamps of power system rubber hoses	0.25-0.3
Clamps of cooling system hoses	0.39-0.6
Bolts of cooling system pump pulley	2.2-2.7
Cooling system pump bolts	2.2-2.7
Idle run regulator clamp bolts	0.6-0.9
Bolt for fastening sensors (knock sensor, cam position sensor, crank angle sensor)	0.6-0.9
Cooling system temperature sensor	1.2-1.8
Air temperature sensor	1.2-1.8
Oxygen sensor	3.5
Throttle position sensor	0.3
Ignition coil bolts	0.6-0.9

ZMZ-40905 ENGINE:

Main bearing caps bolts	10-11
Connecting rods bolt nuts	6.8-7.5
Flywheel bolts	7.2-8.0
Bolts of clutch pressure plate	2.0-2.5
Bolts of seal holder	0.6-0.9
Tie bolt or crankshaft pulley ratchet	17-22
Camshaft caps bolts	1.9-2.3
Camshaft sprocket bolt	5.6-6.2
Bolts for fastening sprockets of intermediate shaft	2.5-2.7
Upper and middle chain stabilizers bolts	2.0-2.5
Lower stabilizer bolts	2.7-3.0
Tightener rod strut bolts	2.7-3.0
Tightener rod bolts	2.7-3.0
Cylinder head front cap bolt	1.2-1.8
Bolts and nuts for fastening crankcase to cylinder block and crankcase amplifier	4.2-5.1
Thermostat housing screws	2.0-2.5
Water pump and chain cap screws	2.0-2.5
Bolt for fastening water pump to the chain cap	1.9-2.3
Water pump pulley fastening bolts	1.4-1.8
Tighteners bolts for hydro-tensioner caps	2.0-2.5
Oil filter connection	4.0-6.0
Bolts for fastening oil pump cap	2.0-2.5
Water pump drive belt tension roller bolt	1.4-1.8
Oil crankcase fastening nuts	1.1-1.6
Oil crankcase bolts	1.2-1.8
Valve cap fastening bolts	0.7-0.9
Exhaust manifold fastening nuts	2.0-2.5
Inlet pipe fastening nuts	2.9-3.6
Receiver fastening nuts	2.0-2.5

Appendix 2 (continued)

Fuel pipe with nozzles fastening bolts	0.6-0.9
Nuts for fastening alternator to upper and lower brackets	2.0-2.5
Alternator pulley fastening nut (M16X1.5)	7.0-8.0
Starter motor fastening bolts	4.4-5.6
Detonation sensor fastening bolt	1.5-2.5
Timing and synchronization phase sensor tightening bolts	0.6-0.9
Spark plugs	2.3-3.1
Clamps of thermostat hoses and heating tube	0.4-0.6
Clamps of main ventilation branch hose	0.4-0.6
Clamps of minor ventilation branch hose	0.1-0.3
Attachment of ventilator drive sleeve to shaft	4.1-5.1
Bolt for fastening engine front strut to brackets	9.0-11.0
Bolt for fastening engine rear strut to bracket	7.0-10.0
Bolts for fastening brackets of front engine supports to the cylinder block	2.8-3.6
Bolts for fastening engine front strut to frame	5.0-6.2
Bolts for fastening engine rear bracket to gearbox crankcase	5.0-6.2
Bolts for fastening cylinder head to cylinder block:	
preliminary tightening;	4-5
exposure not less than 1 minute 15 seconds;	
final tightening.	additional turn to angle 90
Bolts for fastening cylinder head to chain cap	2.0-2.5
Screw for fastening water pump drive belt of automatic tensioner	4.0-5.0
Screws for fastening throttle module	0.6-0.9
Nuts for fastening ignition coil	0.3-0.5

ZMZ-51432 ENGINE:

Main bearing caps bolts	10-11
Connecting rods bolts	6.8-7.5
Bolts for fastening cylinder head to block:	
preliminary tightening	4.0-6.0
1-st interim tightening in 2 minutes	12-13.5
2-nd interim tightening in 2 minutes	15.0-16.5
final tightening in 7 minutes: unscrew bolts to angle 90°-100°, then tighten with torque of	15.0-16.5
Screws for fastening cylinder head to cylinder block	2.2-2.7
Bolts for fastening flywheel	7.2-8.0
Pressure plate bolts	2.0-2.5
Camshaft caps bolts	1.9-2.3
Crankshaft tie bolt	20.0-25.0
Camshaft tie bolts	10.0-11.0
Nuts for fastening inlet pipe	2.9-3.6
Nuts for fastening exhaust manifold and turbo-compressor	2.2-2.7
Cylinder head front cap bolts	2.2-2.4
Chain cap screws	2.2-2.7
Bolts of seal holder	0.6-0.9
Valve cap bolts	0.6-1.2

Appendix 2 (continued)

Thermostat housing screws	2.2-2.7
Bolts of fastening oil crankcase to cylinder block	1.2-1.8
Bolts for fastening oil crankcase to the chain cap and seal holder	1.1-1.6
Bolts of cooling system pump pulley	1.2-1.8
Bolts for fastening starter motor	4.4-5.6
Bolts and nuts for fastening oil pump bracket	3.5-4.0
Bolt for fastening injection pump to fuel pump bracket and alternator	1.6-2.0
Nut for fastening injection pump to rear support	1.6-2.0
Nuts for fastening alternator	2.2-3.2
Clip and nozzle cramp nuts	3.2-3.6
High-pressure fuel pipe nuts	2.2-2.5
Intermediate shaft sprocket bolts	2.5-2.7
Hydraulic power steering pump bolts	5.0-6.2
Nut for fastening Injection pump drive belt tension roller nut	1.2-1.8
Bolt for fastening turbo-compressor inlet nozzle	0.4-0.6
Screws for fastening cooling system pump	2.2-2.7
Bolts for fastening cooling system pump to chain cap	2.0-2.5
Bolt for fastening cooling system pump drive belt tension roller and alternator	1.4-1.8
Bolt for fastening injection pipe rear strut to cylinder head	3.5-4.0
Bolt for fastening alternator to fuel pump bracket and alternator	3.5-4.0
Bolts for fastening engine rear bracket to gearbox crankcase	5.0-6.2
Oil filter union nut	4.1-6.1
Oil filter union	4.1-6.1
Oil crankcase drain plug	2.5-3.0
Nuts of bolts for fastening propeller shaft flanges	4.4-5.6
Bolts and nuts for fastening gearbox and transfer case	4.0-5.6
Bolts for fastening ring gear to differential box	10-14
Bolts for fastening axle crankcase caps	1.1-2.5
Pin nut	8-10
U-bolts nuts	9-10
Spring shackle pin nuts	8.5-9.5
Axle shaft nut	8.0-10.0
Shock absorber nuts	5.6-6.2
Wheel nuts	10-12
Front wheels pins bolts	3.6-4.4
Bolts for fastening front axle hub flanges and rear axle shafts flanges	6.0-7.0
Nut for fastening steering arm to shaft	20-28
Steering trapezium ball stud nuts	6.0-8.0
Bolts for fastening front disc brake to steering knuckle housing	14.0-16.0
Bolts for fastening rear brake shields	4.4-5.6
Nuts of pipelines, terminals, hoses, brake units bypass valves	1.4-1.9
Clutch drive tube nuts	2.8-3.6
Clutch of steel slave cylinder bleeder unit	1.5-2.2
Clutch of plastic slave cylinder bleeder unit	0.4-0.5

Appendix 2 (end)

Nuts of bolts for fastening longitudinal levers and suspension control arm	14-16
Tie rod lock-nuts	10.5-13.0
Bolts for fastening ball struts	3.6-5.0
Wheel hub bearings lock-nuts:	
during bearings adjustment	2.0-3.0
during bearings replacement	3.0-4.0
Union bolt for fastening hydraulic power steering hose	5.0-6.2
Bolts for fastening steering mechanism	5.5-8.0
Nut for fastening steering wheel	6.5-8.0
Steering knuckle lever stud nuts	8.0-10.0
Self-locking nut for fastening inlet nozzle	4.6-5.1

Note. Use the following tightening torque for other threaded couplings,
kgf·m:

M6 — (0.45-1.0)
M8 — (1.4-1.8)
M10 — (3.00-3.5)

LUBRICANTS MATERIALS AND SPECIAL FLUIDS

Places of lubrication/filling	Name of lubricant or fluid	
	Basic	Foreign
Engine lubrication system	Engine oils	
	SAE 0W-30 — from -30 to +20°C; ¹⁾	
	SAE 0W-40 — from -30 to +25°C; ¹⁾	
	SAE 5W-30 — from -25 to +20°C;	
	SAE 5W-40 — from -25 to +35°C;	
	SAE 10W-30 — from -20 to +30°C;	
	SAE 10W-40 — from -20 to +35°C;	
	SAE 15W-30 — from -15 to +35°C;	
	SAE 15W-40 — from -15 to +45°C;	
	SAE 20W-40 — from -10 to +45°C;	
	SAE 20W-50 — from -10 to +45°C;	
	SAE 30 — from -5 to plus 40°C;	
	SAE 40 — from 0 to +45°C;	
	SAE 50 — from 0 to +45°C;	
	by operating properties:	
	Gasoline engines:	
	STO AAI-003-05 — B4, B4/D2, B5; API — SG, SH, SJ, SL	
	Diesel engines:	
	STO AAI-003-98 — D3/B4 or D3; API — CF-4/SG or CF-4	

¹⁾ Only for motor vehicles with gasoline engine

Places of lubrication/filling	Name of lubricant or fluid	
	Basic	Foreign
Gearbox housing	Transmission oils	
	ZIC G-F Top75W-85; ZIC G-FF 75W-85; Hanval Inc. GT OIL GT Transmission FF SAE 75W-85 acc. to API GL-4	
Transfer case housing when equipped with the gearbox made in China when equipped with the Dymos gearbox	The same as in the gearbox All-weather: (at temperature not lower than -25°C) TSp-15K; TAP-15V; TAD-17I Only in winter time (01.10–01.04) — TSp-10	All-weather: SAE 75W-90 acc. to API GL-3
Main drive housings of front and rear axles	For all seasons: SAE 75W-90 acc. to GL-5 of API classification	
Oil tank of hydraulic power steering system	Brand "P"; THK ATF IID; Lukoil ATF; G-Box Exper ATF DX III; Tatneft "r-oil"	Mobil ATF220
Front and rear drive shaft splines, front and rear drive shaft pins steering shaft bearings, steering knuckle pins, front and rear wheels hub bearings "Lita", gearbox input shaft lubricant acc. to NLGJ 3	Plastic lubricants	
	All-weather: "Litol-24"; "Litol-24PK";	All-weather: Lithium

Places of lubrication/filling	Name of lubricant or fluid	
	Basic	Foreign
front bearing, steering shaft splines, clutch release bearing sleeve, parking brake expanding and adjusting mechanisms parking brake drive cable, battery terminals		
Steering knuckle joints	SRUS-4; SRUS-4M	Retinax HDX2
Locks, hinges and door stops, fuel tank filler neck hatch cap hinge hood hinge; mechanism front seats adjustment, rear seat folding and attachment mechanism, front wheels switching off clutch	CIATIM-201	Centuri 1180
Disc brake mechanisms guiding bushes	UNIOL 2M1	
Rear springs	Graphite grease USSa	Lithium lubricant according to NLGJ 3
Rubber weatherstrips	Graphite powder	Barbatia Grease 2
Clutch and brake system hydraulic drives	Fluids	
	Brake fluid: ROSDOT; ROSDOT-4; Rosa Dot-4; Rosa-3;	SAE 1703F; DOT-4
Engine cooling system	Cooling fluid: OZh-40, OZh-65 "Lena"; OZh-40, OZh-65 "TOSOL-TS"; TOSOL A-40M, A-65M;	Shell safe
Windshield washer and headlamps cleaner tank	"View", motor vehicle cleaner-2	

**INFORMATION ON PRECIOUS METALS IN ELECTRONIC EQUIPMENT
IN UAZ MOTOR VEHICLES**

Type of product	Name of product	Precious metal	Weight, g	Quantity of products per UAZ motoe vehicle	
				315195	315148
147.3805	Dashboard	Silver	0.0138258	-	1
144.3805	Dashboard	Silver	0.0138258	1	-
6202.3827	Fuel level sensor	Silver	0.013633		
		Palladium	0,0048156		
		Ruthenium	0.0008236	1	2
TM111-03	Coolant emergency overheating sensor	Silver	0.1485		
23.3829	Oil pressure sensor	Silver	0.017848	1	1
		Palladium	0.0018377		
		Ruthenium	0.00049569	1	-
3902.3829	Oil pressure sensor	Silver	0.02412		
		Palladium	0.0029		
		Ruthenium	0.00224	-	1
6002.3829	Oil emergency pressure sensor	Silver	0.0310	1	1
101.3839	Brake fluid emergency level sensor	Gold	0.01198	1	1
		Silver	0.029064		
PR502	Windshield wiper fuse	Silver	0.06595	1	1
642.3747	Turn indicators flasher	Silver	0.0208	1	1
		Palladium	0.112		

Appendix 4 (end)

Type of product	Name of product	Precious metal	Weight, g	Quantity of products per UAZ moteo vehicle	
				315195	315148
528.3747-01	Windshield wiper flasher	Silver	0.00053	1	1
245.3710	Emergency/Hazard switch	Silver	0.107	1	1
82.3710-05.09	Heater switch	Silver	0.34551	1	1
82.3710-06.10	Fuel tanks switch	Silver	0.46068	1	1
3832.3710- -10.03	Fog lights switch	Silver	0.2033	1	1
3832.3710- -11.04	Rear fog lights switch	Silver	0.2033	1	1
3832.3710- -02.09	Cabin dome lighting switch	Silver	0.0565	1	1

CONTENTS

Chapter 1. General Information	3
Motor vehicle markings	3
Technical specifications	7
Chapter 2. Safety Requirements and Warnings.....	15
Safety requirements.....	15
Warnings.....	18
Chapter 3. Controls and Equipment in Driver/Passenger Compartment	21
Interior and exterior equipment of the motor vehicle.....	28
Doors.....	28
Seats.....	29
Filler necks of fuel tanks.....	32
Hood.....	33
Safety belts.....	33
Window wipers and water cleaning pumps	35
CInterior heating and ventilation.....	35
Chapter 4. Motor vehicle preparation upon receipt from the manufacturer.	37
Chapter 5. New vehicle run-in	37
Chapter 6. Engine start and shutdown.....	38
Engine start.....	38
General	38
ZMZ-40905 engine start.....	39
ZMZ-51432 engine starting	40
Engine shutdown	40
Chapter 7. Vehicle Driving in Different Road, Weather and Climatic Conditions	41
Chapter 8. Vehicle Towing	45
Chapter 9. Vehicle maintenance.....	46
Daily maintenance.....	46
Vehicle maintenance every 500 km.....	46
Seasonal maintenance.....	47
Prior to summer operation.....	47
Prior to winter operation	47
ZMZ-40905 engine.....	47
Engine suspension.....	47
Engine cylinder head	47
Engine gas distribution mechanism.....	48
Engine lubrication system	48
Engine crankcase ventilation system	51
Engine cooling system.....	52
Exhaust system.....	55
Fuel injection system with microprocessor-controlled fuel supply and ignition.....	56
Precautions	57
Fuel system	58
Fuel supply and ignition control system	62
ZMZ-51432 engine.....	63
Engine suspension.....	63
Gas distribution mechanism.....	63

Engine lubrication system	64
Crankcase ventilation system	66
Cooling system.....	67
Replacement and tension of drive belts of the power steering fan and pump, generator, cooling system pump, and high-pressure fuel pump (HPFP).....	70
Exhaust system.....	71
Exhaust gas recirculation system.....	72
Inspecting smoke at the exhaust	73
Microprocessor-controlled fuel injection system.....	73
Fuel system	73
Turbocharger.....	78
Engine control system.....	79
Transmission	81
Clutch	81
The gearbox and the transfer case.....	82
Drive shaft	84
Driving axles	85
Chassis	88
Suspension	88
Wheels and tires.....	89
Wheel hubs	90
Control systems.....	93
Steering system	93
Brake systems.....	95
Electric equipment.....	106
Alternator.....	106
Battery	106
Starter	107
Lighting System, Light and Audio Alarm	107
Relays and fuses	109
Instrumentation and warning alarms.....	111
Vehicle body	113
Lubrication of the vehicle	114
Chapter 10. Special tools and appliances.....	115
Chapter 11. Preservation.....	117
Maintenance of a stored vehicle	118
De-preservation	119
Chapter 12. Transportation.....	119
Chapter 13. Scrapping	119
Appendix 1. Vehicle lamps	120
Appendix 2. Tightening torque of main threaded couplings	121
Appendix 3. Lubricants materials and special fluids	125
Appendix 4. Information on precious metals in electronic equipment in UAZ motor vehicles	128

For Notes

For Notes

For Notes

For Notes

Motor vehicles
UAZ-315195, UAZ-315148
and their modifications

Operating Manual
RE 05808600.133-2012
3rd Edition

Prepared for publishing by Chief Design Department of UAZ PJSC

Editor-in-chief
Chief and Designer O.A. KRUPIN
Editor I.L. NIKOLAEV
Content by D.A. SHEMYREV

