

**Open Joint-Stock Company
"Ulyanovsky Avtomobilny Zavod"**



**Automobiles
YA3-3741, YA3-3962,
YA3-3909, YA3-2206,
YA3-3303
and Their Modifications**

Instruction Manual

2001

This instruction manual contains the brief description of the design and necessary operating and maintenance instructions.

Since efforts are continually made to improve the reliability and performance of the automobiles, minor changes may be introduced without special notice.

We wish You a good trip!

IMPORTANT!

To ensure trouble-free operation of the automobiles, we recommend that You should attentively familiarize yourself with the present publication and follow all the operating and maintenance instructions laid down therein.

You can trust the maintenance of your automobile to one of the service stations recommended by the Sellers. These service stations are well stocked with spares, special appliances and tools. All the maintenance operations are performed by experienced specialists.

Safety Instructions

- 1. Before a trip, check the condition of the lock mechanisms of the hood and the body doors.*
- 2. When using the low-freezing fluid, leaded gasoline and brake fluid, do the following:*
 - avoid any operations which could lead to penetration of these fluids or their steams into the mouth cavity;*
 - do not let to dry the liquid which is ocured on the skin, but wash it off right away with warm water and soap;*
 - never spill liquids in the interior or indoors. Should spillage occur, wash off the spilled place with water and ventilate it;*
 - take off the spilled clothes, wash and dry it outdoors;*
 - wet with kerosene the carbon of leaded gasoline when scraping it off to avoid penetrating of toxic particles of carbon into the respiratory organs.*
- 3. To avoid scalding, open the radiator cap of the engine cooling system with care.*
- 4. Do not warm up the automobile assemblies with free flame.*
- 5. Cut out the storage battery after driving and also in case of short circuit of wiring.*

Precautions

- 1. Do not begin driving the automobile with the cold engine. After starting the engine from cold, never run it at a high crankshaft speed.*
- 2. Cut in the oil cooler at an ambient temperature above 20 ° C, and when riding under hard service conditions (at heavy loads and a high crankshaft speed) independing on ambient temperature.*
- 3. Shift the gearbox in the reverse gear and shift the transfer case to low range only when the automobile is stationary.*

4. *When descending a steep downhill:*
- do not shut down the engine to avoid loss of the efficiency of the brakes provided with the vacuum booster;
- do not disengage the clutch to avoid breaking of the clutch driven disk.

5. *When riding on dry hard-surface roads, disengage the front axle. When the front wheels are disengaged, never engage the front axle.*

6. *If one of the hydraulic brake circuits is a failure, the travel of the brake pedal is increased, and the braking efficiency is decreased.*

7. *When using the gun with the unscrewed tip, take out the spring and the ball in order to avoid their falling in the assemblies with liquid grease.*

8. *Avoid falling acides, soda solutions, braking fluids, antifreeze and fuel on the painted surfaces of the body and rubber parts.*

9. *Do not allow impact loads on the chassis of the automobile. When a strong impact of the front wheels is occurred, inspect carefully the wheels, all parts of the front axle, steering rods, steering mechanism, oil sump, eliminate defects, if required.*

10. *To avoid heavy loads on the axle differential, do not allow a prolonged slipping.*

11. *Use the warmth-keeping hood for radiator shell to provide the proper temperature condition for engine at an ambient temperature below 0 °C.*

12. *When the automobile is to be operated at a temperature below -30 °C, do not fail to disengage the front axle.*

13. *The automobile is provided with a towing hook allowing a short-time operation with a trailer. Do not tow a trailer on rugged ground.*

14. *Do not transport at the same time passengers and cargoes (except for a hand luggage) in the passenger and the sanitary compartments of the automobiles YA3-2206, YA3-3909, YA3-3962, in the cargo compartment of the automobile YA3-3741 equipped with the hinged seats, on the platform of the automobiles YA3-3303, YA3-33036, YA3-39094, YA3-39095 equipped with the hinged seats and the tarpaulin.*

The automobile design is provided with special parts to fasten cargoes.

15. *Since efforts are continually made to improve the reliability and performance of the automobiles, minor changes may be introduced without special notices.*

INTRODUCTION

The automobiles YA3 with a wheel arrangement 4x4 are designed for operating on roads of all types, at all climatic conditions, in all seasons, at ambient temperatures from -45 °C to + 40°C .

The OJSC UAZ manufactures automobiles of the following models and modifications:

YA3-3741, YA3-37419 (Fig. 1) - vans with all-metal closed wagon-type body divided into a two-seat cab and a cargo compartment. The vans are intended for cargo transportation;

YA3-3962, YA3-39629 (Fig. 2) - ambulance cars with wagon-type body divided into a two-seat cab and a sanitary compartment. The ambulance cars are intended for transportation of invalids and could be used for service of emergency aid in towns and countries;

YA3-39625 and YA3- 396259 - special vehicles with wagon-type body divided into a two-seat cab and a passenger/cargo (seven-seat) compartment. The vehicles are intended for passenger/cargo transportation. The vehicles YA3-39625 and YA3-396259 are manufactured on the base of the vehicles YA3-3962 and YA3-39629 correspondingly and have the same specifications;

YA3-3909, YA3-39099 (Fig. 3) - special vehicles with wagon-type body divided into a two-seat cab, a five-seat passenger compartment and a cargo compartment. The vehicles are intended for cargo/passenger transportation;

YA3-2206, YA3-22069 (Fig. 4) - buses with wagon-type body divided into a two-seat cab and a passenger compartment. The buses are intended for passenger transportation;

YA3-3303, YA3-33039 (Fig. 5) - cargo vehicles with two-seat cab and wooden platform. The cargo vehicles are intended for cargo transportation*;

YA3 - 33036 (Fig. 6) - a cargo vehicle with the enlarged wheel base, two-seat cab, metal or wooden platform. The cargo vehicles are intended for cargo transportation*;

* To transport passengers on the platform equipped with hinged seats at the front side is allowed, if there is no cargo on the platform.

YA3-39095 (Fig. 7) - a special vehicle with the enlarged wheel base, two-seat cab and metal platform for municipal economy, cooperative and individual farmings. The vehicles are intended for cargo transportation*;

YA3-39094 (Fig. 8) - a special vehicle with the enlarged wheel base, five-seat cab and metal platform for municipal economy, cooperative and individual farmings. The vehicles are intended for passenger/cargo transportation*;

The vehicles YA3-37419, YA3-39629, YA3-39099, YA3-22069, YA3-33039 differ from the vehicles YA3-3741, YA3-3962, YA3-3909, YA3-2206, YA3-3303 correspondingly in the engine of increased power.

The vehicles YA3-33036, YA3-39094, YA3-39095 are equipped with the engine of increased power.

AUTOMOBILE MARKING

The identification number (Fig. 9) is indented on the nameplate and on the roof channel (on the automobiles YA3-2206, YA3-3962 and their modifications - at two points “a” and “б”; on the automobiles YA3-3303, YA3-3741, YA3-3909, YA3-33036, YA3-39094, YA3-39095 and their modifications - at one point “б”).

The nameplate is fixed on the upright side of the front r.h. wheel case. The engine model and make are also indicated in the nameplate.

The body (cab) number is indented on the level panel of the front r.h. door aperture.

The chassis number is indented on the rear r.h. cross-member end of the frame.

The engine number (Fig. 10) is indented on the l.h. side of the cylinder block.

* To transport passengers on the platform equipped with hinged seats at the front side is allowed, if there is no cargo on the platform.

L

Fig. 1. Overall dimensions (approximately) of automobiles YA3-3741, YA3-37419 (Dimensions are given for reference)

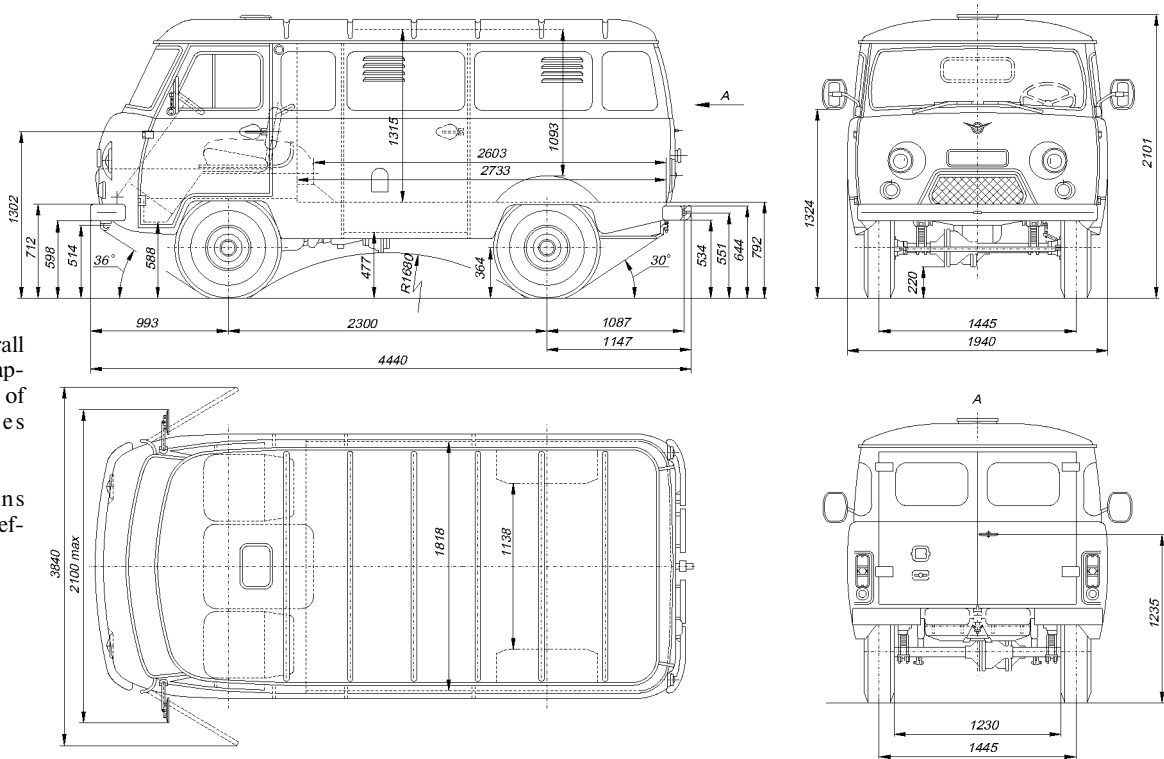

Fig. 2. Overall dimensions (approximately) of automobiles YA3-3962, YA3-39629 (Dimensions are given for reference)

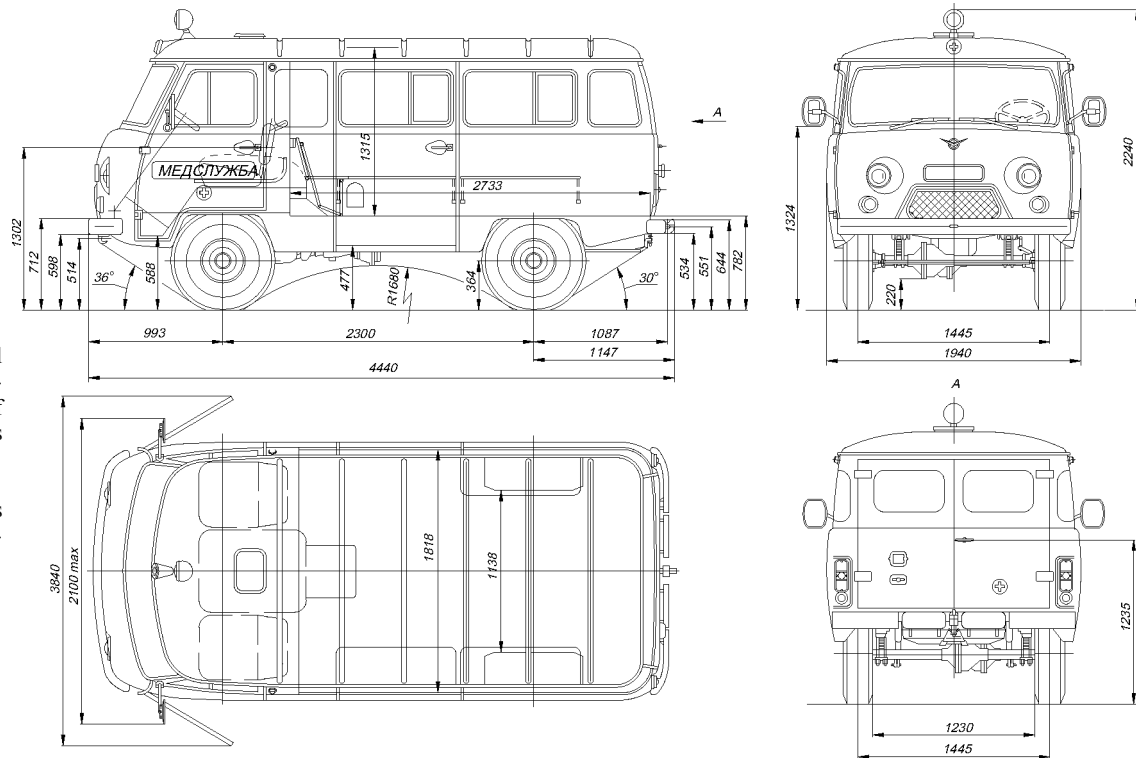

Fig. 3. Overall dimensions (approximately) of automobiles YA3-3909, YA3-39099 (Dimensions are given for reference)

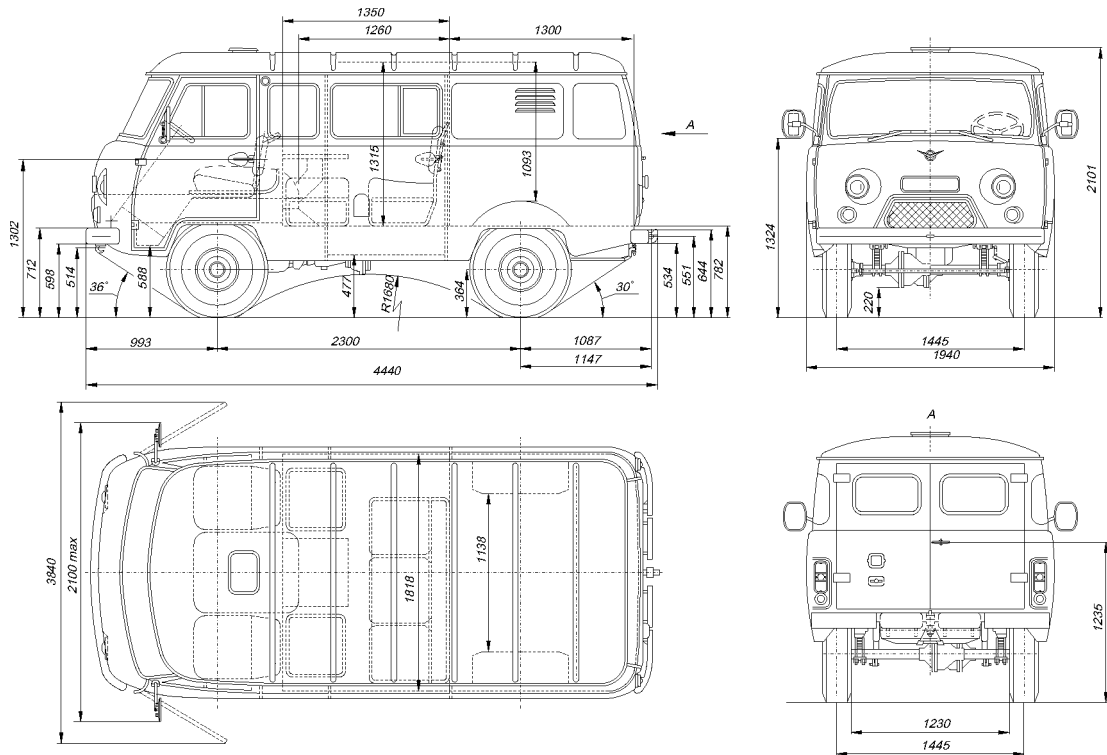

Fig. 4. Overall dimensions (approximately) of automobiles YA3-2206, YA3-22069 (Dimensions are given for reference)

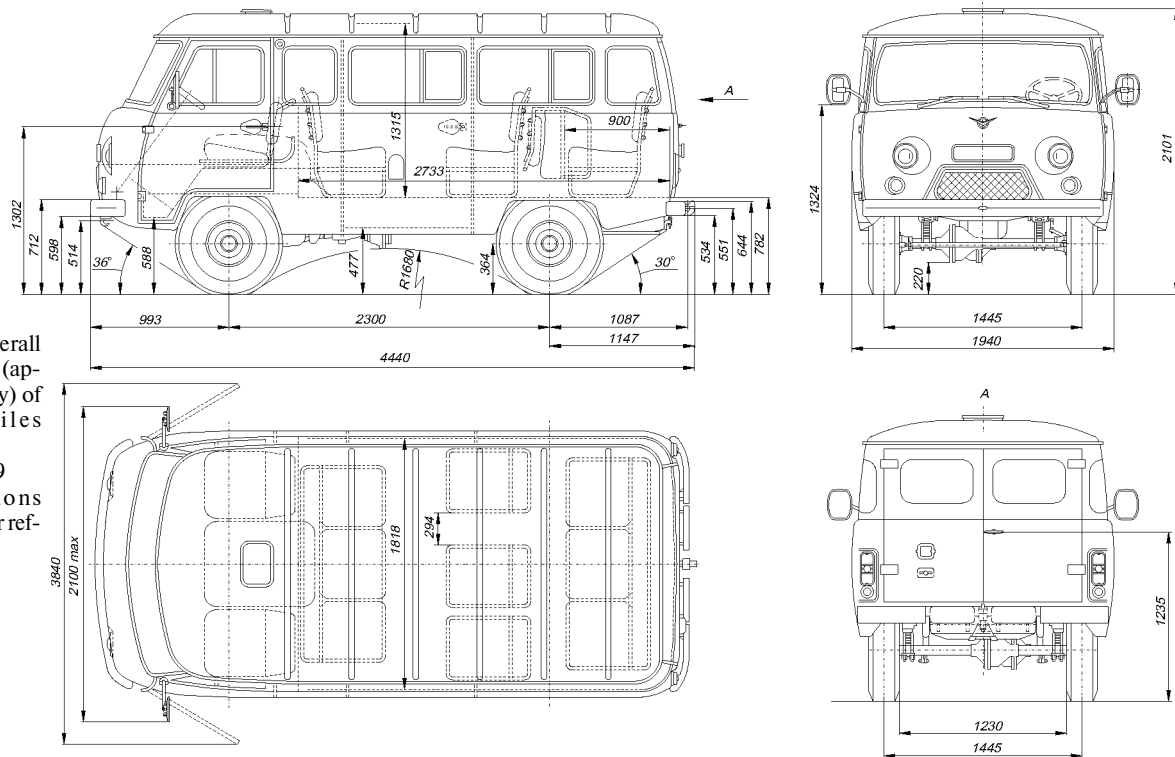

Fig. 6. Overall dimensions (approximately) of automobiles VA3-33036 (Dimensions are given for reference)

* For automobiles with wooden platform and high sides

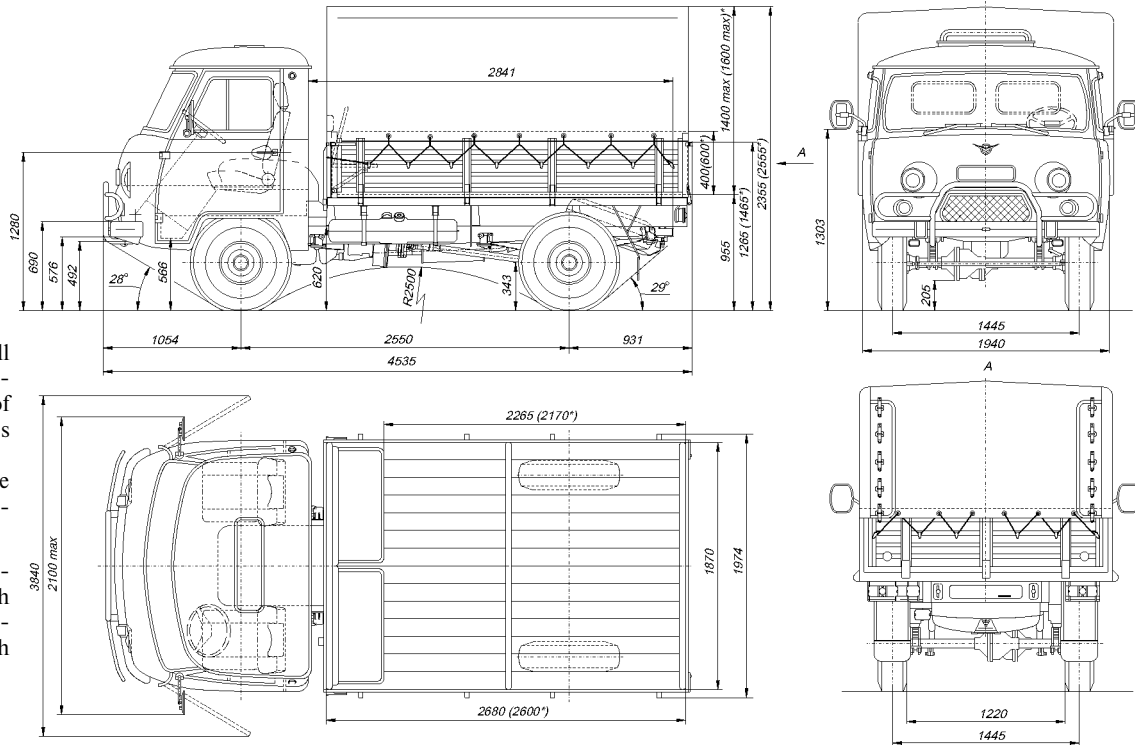

Fig. 7. Overall dimensions (approximately) of automobiles YA3-39095 (Dimensions are given for reference)

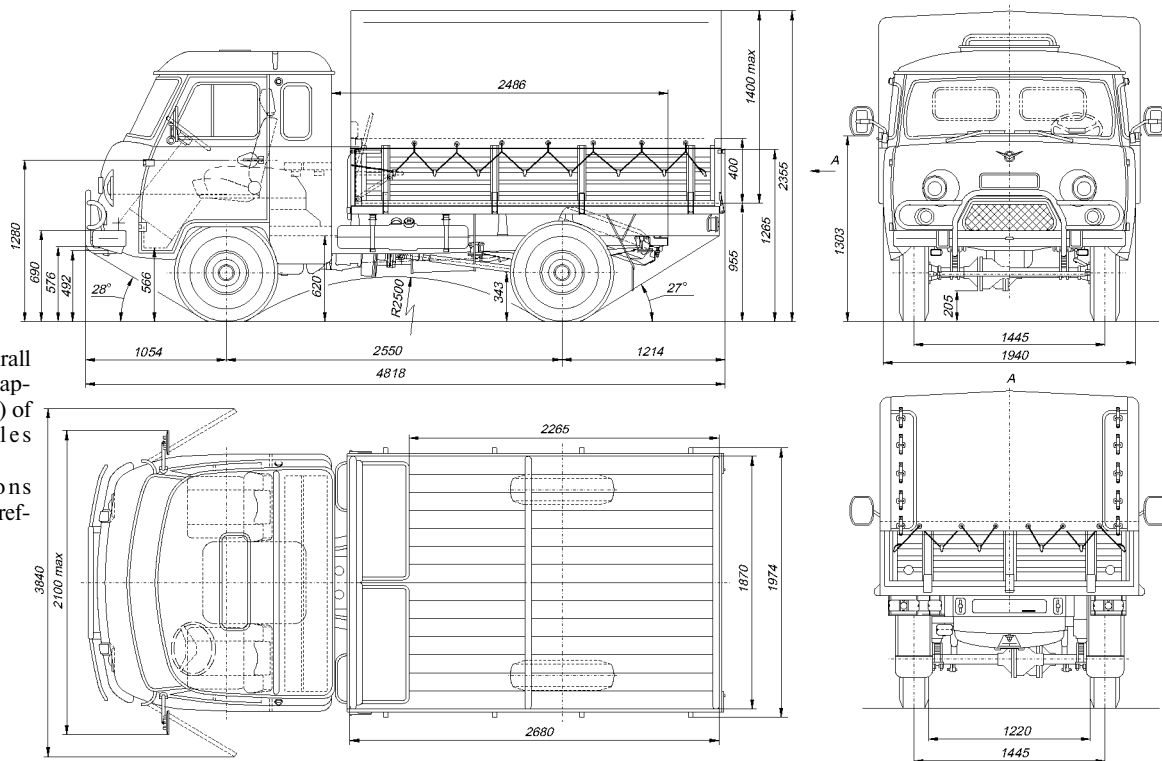
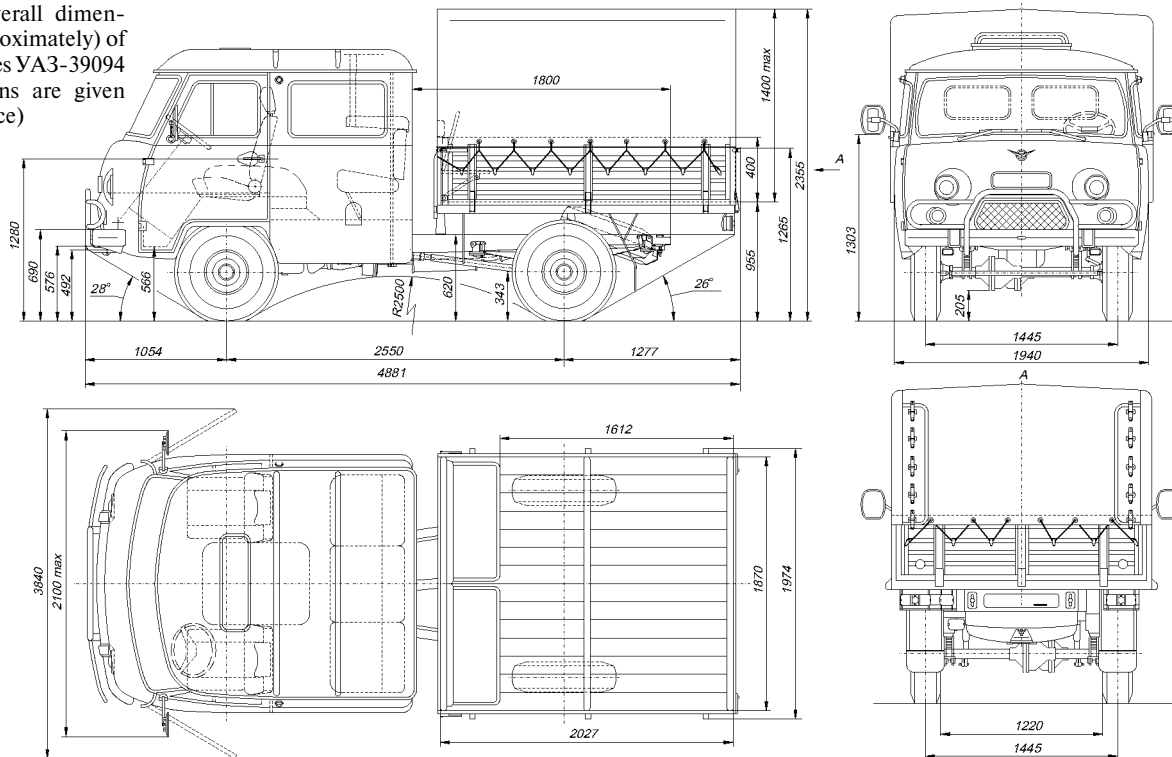

Fig. 8. Overall dimensions (approximately) of automobiles YA3-39094 (Dimensions are given for reference)



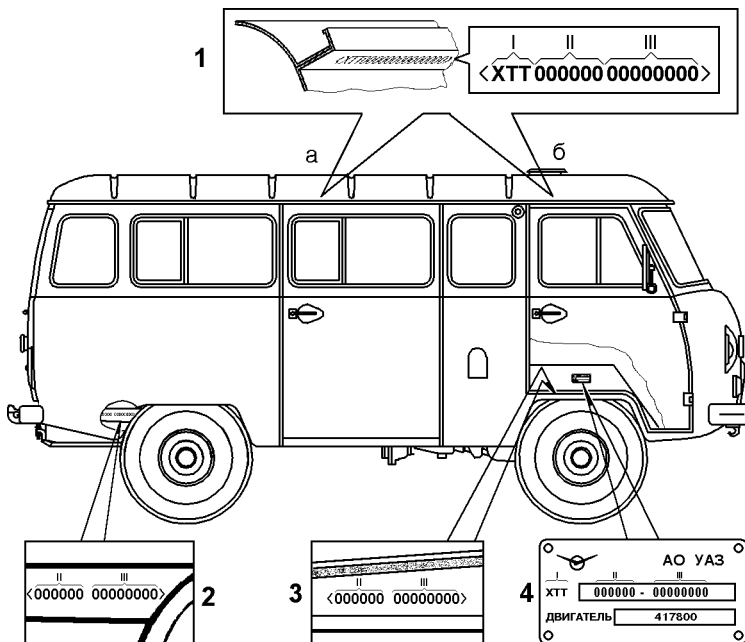

Fig. 9. Automobile marking:

1 - identification number of automobile:

a, б - for automobiles УАЗ-2206, УАЗ-3962 and their modifications;

б - for automobiles УАЗ-3303, УАЗ-3741, УАЗ-3909, УАЗ-33036, УАЗ-39094, УАЗ-39095 and their modifications;

2 -chassis number;

3 -body (cab) number;

4 -nameplate;

I -international code of manufacturer;

II -descriptive part (automobile model, make);

III -indicating part (year of automobile manufacture and serial number of automobile)

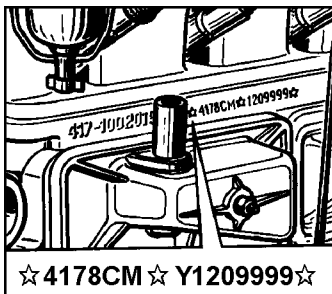

Fig. 10. Location of engine number

SPECIFICATIONS

Description	Models of Automobiles YA3							
	3741, 37419,	3962, 39629,	3909, 39099	2206, 22069	3303, 33039	33036	39094	39095
1	2	3	4	5	6	7	8	9
	GENERAL DATA							
	(Overall dimensions of automobiles are given in Fig. 1 - 8)							
Automobile type	two-axle all-wheel drive cross-country vehicle (4x4 wheel arrangement)							
Max. load capacity (driver and passengers included), kg	1000	- ¹⁾	1000	925	1000	1300	1150	1170
Cargo weight in cargo compartment, kg, not more	-	-	475	-	-	-	-	-
Cargo weight on platform, kg, not more	-	-	-	-	-	-	700	950
Seating capacity (driver included)	2	9	7	11-8 ²⁾	2 or 6 ³⁾	2 or 6 ³⁾	9 ³⁾	6 ³⁾
Permissible total tow weight, kg	2720	2500	2820	2780	2650	3050	3050	3050

16

¹⁾ YA3-39625 and YA3-396259 - 9 persons driver included or 2 persons driver included and 850 kg cargo.

²⁾ Depending upon the version.

³⁾ Depending upon the complete equipment, the platform could be equipped with a removable tarpaulin provided with the frame and two double seats installed along the front side. It is not permitted to transport persons on the platform equipped with seats, if the frame of the tarpaulin is removed (except for platforms with the side height of 614 mm).

	1	2	3	4	5	6	7	8	9
Vehicle total weight distribution, kg:									
front axle		1290	1235	1380	1330	1220	1420	1420	1420
rear axle		1430	1265	1440	1450	1430	1630	1630	1630
Gross weight, kg:		1720	1825	1820	1855	1650	1750	1900	1880
Gross weight distribution, kg:									
front axle		1000	1035	1060	1025	1000	1090	1130	1180
rear axle		720	790	760	830	650	660	770	700
Total tow weight, kg, not more:									
with brakes					1500 ¹⁾				
without brakes					750 ¹⁾				
17 Minimum turning radius by track of front outer wheel (relative to centre of turn), m, not more				6.3				7.0	
Outer turning radius by point of front bumper max. removed from centre of turn, m, not more				6.8				7.5	
Maximum upgrade, deg.						30			
Maximum depth of ford, m						0.5			

¹⁾ To tow a trailer at all times and on rugged ground is allowed only when the automobile is equipped with a towing gear of the ball type.

Description	Models of Automobiles YA3				
	3741, 3962, 3909, 2206	37419, 39629, 39099, 22069	3303	33039	33036, 39094, 39095
Maximum speed, km/h	110	117 ¹⁾	100	110	105

Description	Models of Automobiles YA3	
	3741, 3962, 3909, 2206, 3303	37419, 39629, 39099, 22069, 33039, 33036 39094, 39095
1	2	3

18

	ENGINE	
Model	4178	4218
Cylinder number	4-stroke, carburettor-type	
Cylinder order	four	
Firing order	in-line, vertical	
Cylinder bore, mm	92	100
Piston stroke, mm	92	92
Displacement, l	2.445	2.89
Compression ratio	7.0	7.0
Nominal power at crankshaft speed of 66 s ⁻¹ (4000 min ⁻¹) kW (hp): to DIN 70020	57.4 (78)	63.2 (86)

¹⁾ When the tyres Я-245-1 are installed, in service the maximum speed should be not more than 110 km/h.

	1	2	3
	gross to SAEj 816b	68.4 (93)	73.5 (100)
	net to GOCT 14846	55.9 (76)	61.8 (84)
	Maximum torque at 36-42 s ⁻¹ (2200-2500 min ⁻¹), N · m (kgf · m):		
	to DIN 70020	164.8 (16.8)	193 (19.7)
	gross to SAEj 816b	174.6 (17.8)	201 (20.5)
	net to GOCT 14846	159.8 (16.3)	189 (19.3)
	Minimum low idle speed of crankshaft, s ⁻¹ , (min ⁻¹)	11.6-12.5 (700-750)	
	Lubrication system	Combination: forced and splash	
	Crankcase ventilation	Closed	
	Fuel system	With forced fuel feed and fuel-air mixture heating	
	Fuel	Gasoline with octane number 76	
	Cooling system	Liquid, closed, forced circulation	
		TRANSMISSION	
	Clutch:	Dry, single-disk	
	Type of clutch	Hydraulic	
	Type of drive	Four-speed	
	Gearbox		
	gear ratios	1st speed 3.78	3rd speed 1.55
		2nd speed 2.60	4th speed 1.00
		Reverse 4.12	
	Optional version of gearbox:		
	gear ratios	1st speed 4.124	3rd speed 1.58
		2nd speed 2.641	4th speed 1.00
		Reverse 5.22	
	Transfer box	Two-range	

1	2	3
gear ratios: high range low range	1.00 1.94	
Front and rear driving axles	Final drive - spiral bevel gearing; gear ratio 4.625	
front axle steering knuckle joints	Constant-velocity universal joints of ball type	
Description	Models of Automobiles YA3	
	3741, 37419, 3962, 39629, 3909, 39099, 2206, 22069, 3303, 33039	33036, 39094 39095
1	2	3
	CHASSIS	
Suspension: type	four longitudinal semielliptic springs operating in conjunction with four hydraulic telescopic shock absorbers	
Wheels and tyres: wheels	Steel, with deep-well one-piece rim, size 6L×15 or 6J×16 depending on tyres in use	
tyres	215/90-15C (Я-245-1), 215/90R15C 99N (ЯИ-357A), 225R16C (K-151 or K-152), 225/75R16 108Q (K-153), 225/75R16 (Я-435A)	Tubed 225/75R16 108Q (K-153), 225/75R16 (Я-435A)
Tube size	8.40-15 or 225-16 depending on tyres in use	225-16

1	2	3
	CONTROL SYSTEMS	
Steering arrangement:		
type of steering mechanism	Hourglass worm with double roller	
mean gear ratio		20.3
Brakes:		
service	Shoe, with two separate circuits actuated from two-chamber master cylinder on front and rear wheels	
parking	Drum with inner shoes acting on transmission, with mechanical drive	
	ELECTRICAL EQUIPMENT	
Wiring	Single-wire, with ground returned minus	
Rated voltage, V		12
Overload breakers:		
fuse	Unit, provided with three fuses 10A each in horn, instrument, heater motor and windshield wiper circuits	
thermal cut-out	Button - in lighting circuit	
	ADJUSTMENT DATA	
Valve-to-rocker clearance on cold engine (at 15-20 °C), mm:		
for exhaust valves of No.1 and No. 4 cylinders		0.30-0.35
for the rest of valves		0.35-0.40
Deflection of fan belt when force of 4 kgf is applied, mm		8-14

1	2	3				
Cooling fluid density at 20 °C, g/cm ³ :						
ОЖ-40 "Лена"		1.075-1.085				
ОЖ-65 "Лена"		1.085-1.100				
Spark plug gap, mm		0.85 ^{+0.15}				
Cooling fluid temperature in cooling system, °C		80-90				
Free travel of clutch pedal, mm		35-55				
Free travel of brake pedal, mm		5-14				
Front wheel toe-in, mm		1.5-3.0				
Maximum turning angle of front inner wheel, deg		26-27				
Steering wheel play, deg, not more		10				
	Models of Automobiles YA3					
Tyre Inflation Pressure, kPa (kgf/cm ²)	3741, 37419	3962, 39629	3909, 39099	2206, 22069	3303, 33039	33036, 39094 39095
front wheels:						
Я-245-1	0.19(1.9)	0.19(1.9)	0.22(2.2)	0.20(2.0)	0.19(1.9)	-
ЯИ-357А, К-151, К-152	0.23(2.3)	0.22(2.2)	0.24(2.4)	0.23(2.3)	0.22(2.2)	-
К-153, Я-435А	0.23(2.3)	0.22(2.2)	0.24(2.4)	0.23(2.3)	0.22(2.2)	0.25(2.5)
rear wheels:						
Я-245-1	0.23(2.3)	0.19(1.9)	0.23(2.3)	0.24(2.4)	0.23(2.3)	-
ЯИ-357А, К-151, К-152	0.25(2.5)	0.22(2.2)	0.25(2.5)	0.25(2.5)	0.25(2.5)	-
К-153, Я-435А	0.25(2.5)	0.22(2.2)	0.25(2.5)	0.25(2.5)	0.25(2.5)	0.28(2.8)

FILLING CAPACITIES, l

Description	Models of Automobiles YA3		
	3741, 37419, 39094	3303, 33039, 33036, 39095	3962, 39629, 3909, 39099, 2206, 22069
Fuel tanks:			
main	56	56	56
auxiliary	30 ¹⁾	56 ¹⁾	30
Engine cooling system (heater including)	13.2-13.4	13.2-13.4	14.4-14.6
Engine lubrication system (without oil radiator reservoir)		5.8	
Gearbox		1.0	
Transfer box		0.7	
Front and rear axle housing(each)		0.85	
Steering gear case		0.25	
Shock absorbers (each)		0.320	
Clutch hydraulic system		0.18	
Hydraulic actuated brake system	0.52 (0.55 - on automobiles YA3-33036, YA3-39094, YA3-39095)		
Windshield washer reservoir		2	

23

¹⁾ On automobiles YA3-39094, YA3-3303, YA3-33039, only main fuel tank could be installed

intermediate - neutral; backward - low range is ON; 13 - radiator shutter control handle; 14 - throttle valve control knob; (can be fixed by turning through 90° in any direction); 15 - battery switch; 16 - choke valve control knob (can be fixed by turning through 90° in any direction); 17¹⁾- fuel tank cock handle has three positions: turned to the right - auxiliary (right-hand) fuel tank is cut in; turned forward - the cock is closed; turned to the left - the main (left-hand) fuel tank is cut in; 18 - heater; 19 - parking brake lever; 20 - accelerator pedal; 21 - service brake pedal; 22 - clutch pedal; 23 - foot-operated dimmer switch; 24 - receptacle; 25 - fuse unit; 26 - rear-view mirror (external).

The instrument panel (Fig.13, 14) mounts:

1 - pushbutton of thermal cut-out in the lighting circuit; 2 - main light switch has three positions: first - all lights are OFF; second - the marker lights are ON; third - the marker lights and headlamp low or high beam are ON (depending on the position of the foot-operated dimmer switch); 3 - ignition switch (Fig. 12); 4 - speedometer with trip odometer. The high beam warning lamp (blue)¹⁾ is located on the speedometer dial; 5 - windshield wiper and washer selector switch; the windshield

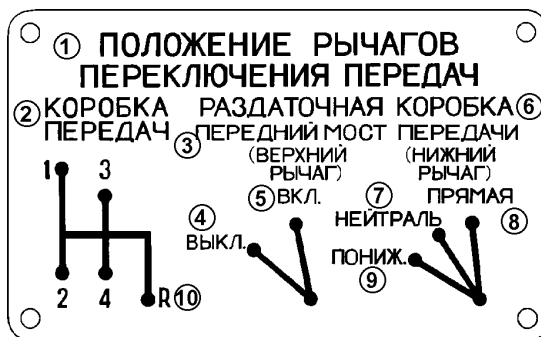

Fig.12. Instruction Plate. "Positions of Transmission, Front Axle and Transfer Case Shift Levers":

1 - positions of shift levers; 2 - transmissions; 3 - front axle; 4 - upper lever; 5 - lower lever; 6 - transfer case; 7 - neutral; 8 - high range; 9 - low range; 10 - reverse movement

¹⁾ On automobiles YA3-39094, YA3-3303, YA3-33039 without auxiliary fuel tank, fuel tank cock handle is not provided.

wiper is switched on by rotating the switch knob and the windshield washer is switched on by depressing the switch knob axially; 6 ²⁾ - fog lamp switch; 7 -rear fog lamp switch with integrated warning lamp; 8 - heater fan electric motor switch; 9 - ash tray; 10 ²⁾ - cigarette lighter; 11 ³⁾ - fuel level gauge selector switch; 12 - emergency flasher warning system knob; 13 - access cover to the reservoir to the clutch hydraulic system; 14 - ammeter; 15 - turn indicator warning lamp (green); 16 - hydraulic brake emergency condition warning lamp (red); 17 ¹⁾ - engine lubrication system oil pressure gauge with low oil pressure built-in warning lamp; 18 -parking brake warning lamp

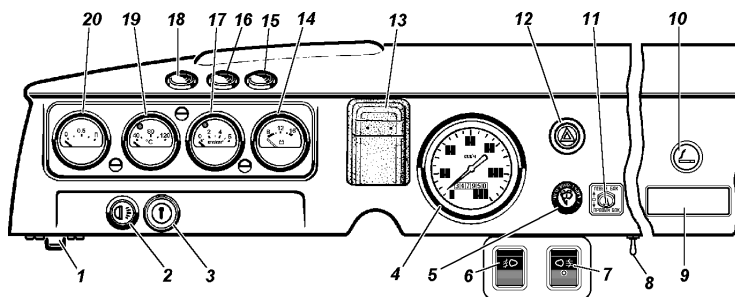

Fig. 13. Instrument panel of automobiles YA3-3741, YA3-3962, YA3-3909, YA3-2206, YA3-3303 (for ref. nos., refer to text)

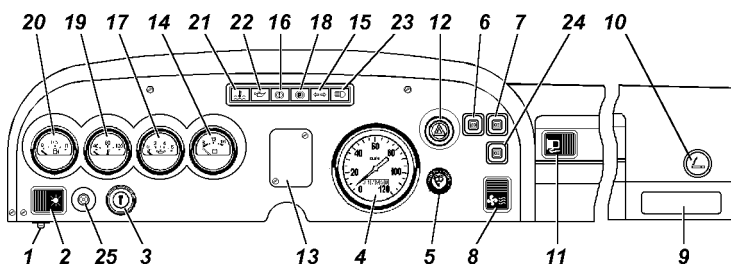

Fig. 14. Instrument panel of automobiles YA3-33036, YA3-39094, YA3-39095 (for ref. nos., refer to text)

¹⁾ On the automobiles YA3-33036, YA3-39094, YA3-39095 the high beam warning lamp, oil emergency pressure warning lamp and radiator coolant emergency overheating warning lamp are located in the warning lamp unit (refer to positions 21, 22, 23 Fig. 15).

²⁾ Installed depending upon a complete equipment of the automobile.

³⁾ Installed on the automobiles YA3-33036, YA3-39095 and on the automobiles YA3-3303, YA3-33039 provided with the auxiliary fuel tank.

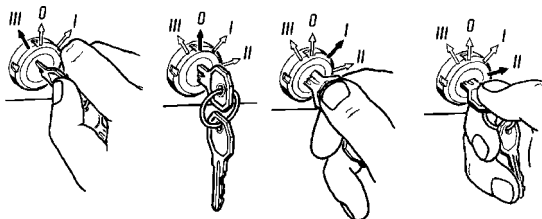

Fig. 15. Position of ignition key:

O -neutral position; I -ignition ON; II -ignition and starter ON; III -radio ON (if available)

(red); 19 ¹⁾ -coolant temperature gauge in the cylinder block with built-in warning lamp in the radiator; 20 - main fuel tank (left-hand) level gauge (on automobiles YA3-33036, YA3-33095 and YA3-3303, YA3-33039 provided with two fuel tanks the gauge indicates fuel level depending on position of the switch 11); 21 - radiator coolant emergency overheating warning lamp; 22 - oil emergency pressure warning lamp; 23 - high beam warning lamp; 24 - dome lamp switch (as a version, the switch is located next to the dome lamp); 25 - instrument lighting adjuster.

PRESTARTING PROCEDURE

Dealers must give Your automobile a Free Service inspection laid down in the service book.

Before driving automobiles from the Manufacturer to Distributors/Dealers, it is necessary to carry out all the operations laid down in the section "Daily Maintenance".

The automobile service life depends to a greater extent on the operating mode during the initial service period. The running-in kilometrage is equal to 1000 km.

AUTOMOBILE RUNNING-IN

During the running-in period, observe the following rules:

1. Do not overload the automobile.
2. Do not move on hard-surfaced roads (deep mud, sandy soils, steep up-grades etc.)

¹⁾ On the automobiles YA3-33036, YA3-39094, YA3-39095 the high beam warning lamp, oil emergency pressure warning lamp and radiator coolant emergency overheating warning lamp are located in the warning lamp unit (refer to positions 21, 22, 23 Fig. 15).

3. Do not exceed the following speed limits:
in direct gear 45-50 km/h;
in the third gear..... 30 km/h;
in the second gear 20 km/h;
in the first gear 12 km/h.
4. Do not change oils filled in the engine and units at the manufacturing plant.
5. Check the temperature of brake drums and in case of raising the temperature, adjust them in compliance with the instructions laid down in the section "Brakes".
6. Check the temperature of wheel hubs and in case of raising the temperature, loosen the tightness of bearings.
7. Check condition of all attachments. Check the connections of pipes; if oils, fuel, coolant and hydraulic fluids leak, eliminate defects.

STARTING AND SHUTTING DOWN THE ENGINE

Starting the Engine

Before starting the engine, check the coolant level in the engine cooling system, fuel level and oil in the engine crankcase.

Prime the carburettor by means of the fuel pump hand primer.

Starting from Cold at 0 °C and Above.

Shift the gearshift lever in the neutral.

Press the throttle valve control pedal (the accelerator pedal) several times.

Disengage the clutch and switch on the ignition and the starter. Switch on the starter for 5 s maximum. Intervals between starting attempts should be at least 10-15 s.

(It is not recommended to switch on the starter for more than three times in succession, stop starting, check the engine, detect and eliminate defects.)

As soon as the engine is started, immediately release the key. Warm up the engine. The temperature of coolant must be not less than 60 °C.

It is forbidden to increase a crankshaft speed for warming-up the engine.

Starting from Cold at Temperatures of 0°C to - 20 °C.

Before starting the engine, carry out the following operations:

1. Close the radiator shutter and mount the radiator shell warmth-keeping cover.

2. Using the starting handle, turn over the engine crankshaft for 3-5 times.

3. Pull the choke control knob all the way out (preliminary, the throttle valve control pedal should be pressed).

Carry out the subsequent operations in the order specified for starting the engine at temperatures of 0 °C and above.

After the engine is warmed up, push the choke control knob all the way in.

Starting from Cold at Temperature Below - 20 °C.

Before starting the engine at a low temperature, warm it up (by means of hot water, steam or air etc.).

Before starting the engine, it is recommended to warm up the transistor commutator, for this purpose switch on the ignition, and start the engine in 3 minutes.

Carry out the subsequent operations in the order specified for starting the engine at temperatures of 0 °C to -20 °C.

Starting from Hot.

When starting from hot, do not push the choke valve control knob in, and the throttle valve control pedal is not be sharply depressed, as it results in overenrichment of the air-fuel mixture, and the engine fails to be started.

To eliminate the overenrichment, blow through the engine cylinders with air for which purpose smoothly depress the throttle valve control pedal up to the toeboard, and immediately turn over the crankshaft by means of the starter for several times.

Shutting down the engine

Before shutting down the engine, let it run for 1-2 minutes at a low crankshaft speed for gradual and uniform cooling and thereafter switch off the ignition.

FEATURES OF DRIVING UNDER DIFFERENT ROAD, METEOROLOGICAL AND CLIMATIC SERVICE CONDITIONS

The operation and service of automobile depends to a greater extent on features of its driving. When driving correct, the automobile could run at a high middle speed and consume not

much fuel when overcoming almost impassable sections of roads. **We recommend to shift in the second gear for starting the automobile away from rest on level sections of roads or on down-grades. In other cases, shift in the first gear for starting away from rest. Disengage the clutch when shifting in gears.**

Move the gearshift lever smoothly and without jerks. If a required gear is not shifted before starting the automobile away from rest, release the clutch pedal gently, and then disengage the clutch again and shift in a gear.

Shift in the reverse gear only after a complete stop of the automobile. When operating the automobile, do not keep the foot on the clutch pedal, as it would result in clutch partial disengaging and disk slipping. On slippery roads, drive the automobile evenly, with a low speed.

When braking engine, release completely the accelerator pedal.

Brake the automobile smoothly by depressing the braking pedal slowly. When braking unnecessarily, the tyres are worn quickly, and the fuel consumption is increased. When braking, do not allow slipping the wheels, as it decreases the efficiency of braking (in comparison with braking during rolling) and increases wear of tyres. Besides, sharply and heavy braking could provoke skidding of the automobile.

When the automobile is to be operated on off-the-road (sand, mud, snow etc.), slippery roads, steep up-grades (more than 15 °C) and on other complicated sections of roads, do not overload the engine. In this case, engage the front axle, and on very complicated sections of roads, shift also the transfer box to a low range. Before engaging the front axle, engage the front wheels. Engage the front axle in motion, and shift the transfer box to low range only after a complete stop of the automobile.

Overcoming Steep Up-Grades and Down-Grades. When driving on roads with steep up-grades and down-grades, a driver should be very intent. Determine preliminarily an up-hill gradient and shift in a required gear which would ensure a required traction force of wheels. When overcoming steep up-grades, shift the transfer box to a low range and the gearbox in the first gear. Overcome up-grades without stopping and turnings, as far as possible. Overcome short up-grades provided with a convenient access and smooth riding surface by speeding

up without engaging the transfer box to a low range and by shifting the gearbox in the second or third gears depending on an up-hill gradient. If for some reason, it is impossible to overcome an up-grade, take all precautions and descend slowly by shifting in the reverse gear. Descend little by little, do not speed up the automobile and do not disengage the clutch. When overcoming steep down-grades, take measures to ensure the safety of descending. When overcoming a long down-grade (more than 50 m), determine preliminarily its steepness, shift the gearbox in a required gear and engage the transfer box to a required range. Overcome such down-grades by engine braking.

Overcoming Gutters, Roadside Cuvettes and Ditches. Overcome gutters, roadside cuvettes and ditches at a low speed with the front axle engaged in the direction perpendicular to a down-grade with regard to dimensions of the automobile defining its cross-country capability. Do not overcome an obstacle with a rush, if a frontal impact against wheels could be occurred .

Moving Along Muddy Country Roads and Graded Clay and Gumbo Roads. When moving on clay and gumbo roads after pouring rain, the automobile could slip off the road. Be careful when choosing a direction of motion. Choose relatively level grounds when moving on rut-roads if possible. It is very difficult to drive the automobile on very wet graded earth roads provided with steep grades and deep cuvetts. On these roads, drive carefully on the crest of the corrugation and at a low speed.

Marsh-Ridden Sections of Roads. Overcome marsh-ridden sections on straight line without sharp turns and stops. Engage the front axle and engage the transfer box to a low range, shift the gearbox in a gear which would provide a required traction force of the driving wheels. Turn smoothly with a great radius, do not decrease a speed. Do not drive on the track paved of an ahead moving automobile.

Sandy Soils. When overcoming sandy soils, drive smoothly without jerks and stops. Turn smoothly and with great radius. Shift in a possible high gear and engage the front axle, overcome sandy drifts and short sandy up-grades in a rush. Do not allow slipping the wheel, determine road conditions preliminarily and shift in a required gear which would provide a required traction force of wheels.

Fording. Overcome a ford with a great care. The automobile

could overcome a ford of a 500 m depth with a hard bottom at a low speed. Before overcoming a ford, check the bottom, make sure that there are no deep pits, big stones, swampy grounds, check the ground where the automobile would enter water and go out of water.

Cut the radiator shutter if it is available.

Overcome a ford slowly, do not make water surface choppy in front of the automobile, shift the gearbox in the first or second gears, engage the front axle and engage the transfer box to a low range.

Avoid manoeuvring and turning sharply.

After fording, as soon as possible but not later than on this day, check oil in all assemblies, change oil in an assembly where water is detected. If oil colour is changed, it means that there is some water in oil. Lubricate all chassis grease nipples till fresh grease would be appeared. After fording, engage the clutch partly several times and brake partly several times for drying the clutch facings and brake shoe linings. If the engine is stopped when fording, try to crank up the engine by means of the starter two-three times. If the engine is not started, the automobile is to be immediately evacuated out of water by all means. If some water is penetrated to the assemblies of the automobile, it is not recommended to run the automobile under its own power. Tow the automobile and carry out the required maintenance.

Snowy Surfaces. The automobile could move along snowy surfaces of 350 mm depth. Turn the automobile in the same manner, as when moving on swampy grounds. When driving on quick snow, do the same, as when driving on sandy surface.

MAINTENANCE OF THE AUTOMOBILE

Intervals and scope of automobile servicing are laid down in the Service Book.

The indications of this section allow both maintenance of the automobile and adjustment of its units to be well carried out. This section indicates also operations which should be carried out in intervals between servicing terms according to the Coupons.

DAILY MAINTENANCE

1. Visually check the automobile for completeness of sets, check the body, glasses, rear view mirrors, licence plates, body coating, door locks, frame, springs, shock absorbers, wheels and tyres for proper condition. Eliminate detected faults.

Inspect the automobile to make sure there are no fuel, coolant, oil and brake fluid leaks. To this end, inspect the parking place.

Eliminate detected faults.

2. Fill up to normal coolant, oil, fuel and brake fluid.

3. Check functioning of lighting devices, signalling devices, windshield wiper. Eliminate defects.

4. Check functioning of the steering gear, brakes. Eliminate defects.

5. If the automobile is not kept in a garage, and is to be stored in cold weather, drain water from cooling system after each run.

6. Fill up the windshield washer reservoir. Use water for filling-up in summer.

7. If the automobile was operated on extremely dusty roads, as well as after fording and negotiation of natural road sections and off-road sections covered with mud, wash the filter element of the air cleaner or replace it.

8. If the automobile was operated on extremely dusty or dirty roads, wash it thereafter.

SEASONAL MAINTENANCE

The seasonal maintenance is carried out twice a year (in the spring and autumn) and, if possible, is combined with the next maintenance according to Coupons of Servicing Book.

Before the Summer Season of Operation

1. Connect the air hose to the air cleaner union and set the manifold heat control valve in the "summer" position.

2. Drain the fuel tanks.

3. Remove the heater and windshield wiper motors, check the conditions of the commutator and blades, wash and lubricate the bearings.

4. Switch on the windshield wiper for 15-20 min; the blades should be swung out of the way.

Before the Winter Season of Operation

1. Disconnect the air hose from the air cleaner union and set the manifold heat control valve in the "winter" position.

2. Wash the fuel tanks and fuel filters.

3. Check coolant specific gravity in the engine cooling system, and if required, fill up to normal.

4. Flush the cooling system once in three years or after 60 000 km of run, drain coolant and refill the cooling system with fresh coolant.

5. Check the heating and body ventilation system for proper functioning.

6. Check the shutters for proper functioning.

7. Flush or replace the air cleaner of the vacuum brake booster.

8. Switch on the windshield wiper for 15-20 min; the blades should be swung out of the way.

ENGINE

The automobile is equipped with the four-cylinder engine with upper valve arrangement which is shown in Fig. 16, 17.

Check and, if required, tighten the engine mounting (Fig. 18). Tighten the engine mounting bolt nuts until distance sleeves touch the washers.

Tighten the cylinder head fastening nuts after completion of the automobile running-in period and every 1 000 km of run each time when removing the cylinder head.

Tighten the nuts only on a cold engine. Tighten the nuts in two steps in the sequence illustrated in Fig. 19: the first step - preliminarily with a less force, the second one - finally; the final tightening torque should be equal to 90-94 N·m (9.0 - 9.4 kgf·m).

As required, clean carbon deposit off the cylinder head, piston crowns and inlet valves.

Valve gear. Adjust the valve-to-rocker clearances on a cold engine using the following sequence:

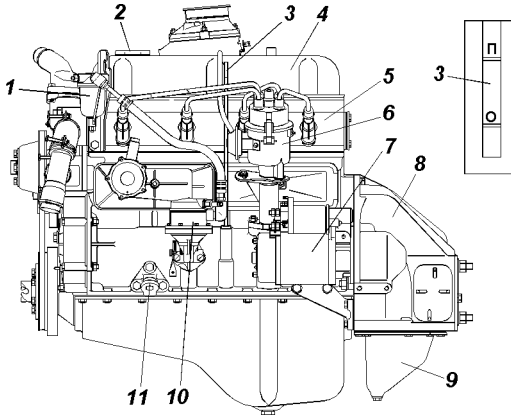

Fig. 16. Engine
(l.h. view):
1 - fine fuel filter; 2 - oil filler cap ; 3 - oil dipstick; 4 - rocker arm cover; 5 -cylinder head; 6 -ignition-distributor; 7 -starter; 8 -clutch housing; 9 -clutch housing (lower part); 10 - fuel pump; 11 -engine mounting bracket

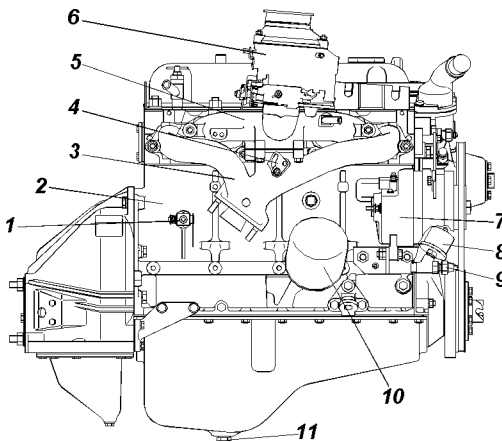

Fig. 17. Engine
(r.h. view):
1 -cylinder block drain cock; 2 -cylinder block; 3 -inlet manifold; 4 - inlet manifold damper; 5 -inlet manifold; 6 - carburettor; 7 -alternator; 8 -oil pressure transmitter; 9 -low oil pressure warning lamp transmitter; 10 -oil filter; 11 -oil sump drain plug

- remove the vacuum governor hose;
- remove the rocker cover;
- using mark (Fig. 20) on the crankshaft pulley, set the piston of No.1 cylinder at the TDC on the compression stroke and check the clearance between the rockers and valves of No.1, 2, 4, 6 with the feeler gauge. In the case of an incorrect clearance, screw out locknut (Fig. 21) of adjusting screw and rotating the letter with a screwdriver, set a required clearance by means of the feeler gauge. Then, holding the adjusting screw with the

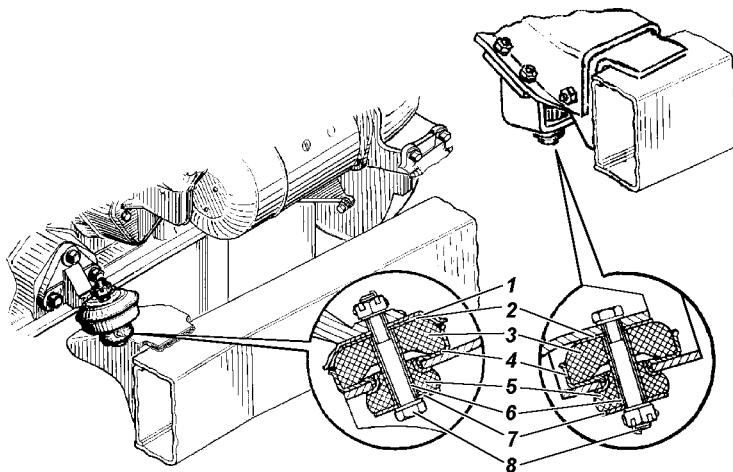

Fig. 18. Engine mounting:

1 -protective cover; 2 -washer; 3 -upper pad; 4 -seat; 5 -lower pad; 6 -distance sleeve; 7 -washer; 8 -bolt

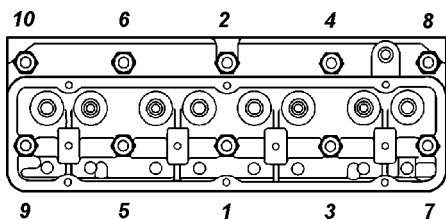

Fig. 19. Sequence of tightening cylinder head nuts

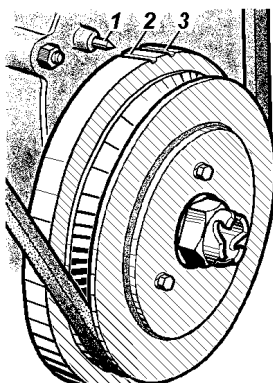

Fig. 20. Timing marks on crankshaft pulley:
1 -index pointer; 2 -mark for setting TDC;
3 -mark for ignition timing

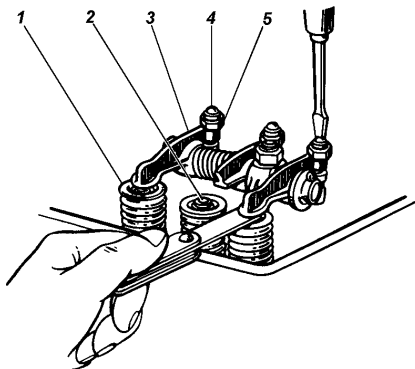

Fig. 21. Adjusting clearance between rocker arm and valve:

- 1 - valve spring retainer; 2 - valve; 3 - rocker; 4 - adjusting screw; 5 - locknut

screwdriver, tighten the locknut and check the clearance for correct setting;

- having adjusted the clearances of one cylinder, turn the crankshaft through half a turn and adjust the clearances on other cylinders (3, 5, 7, 8).

The valve-to-rocker clearances on a cold engine (15-20 °C) for the exhaust valves of No.1 and No.4 cylinders (valves 1 and 8) should be equal to 0.30 - 0.35 mm, and for other valves - 0.35 - 0.40 mm.

Maintenance of the Lubrication System

For cooling oil in the engine lubrication system, an oil cooler is provided. It is recommended to cut in the cooler by opening the cock 7 (Fig. 22) at an ambient temperature above +20 °C. But when riding on heavy roads (with heavy load and at a high engine crankshaft speed), also cut in the cooler independent on an ambient temperature. The level of oil in the engine crankcase should be in register with the mark "II" on oil dipstick 3 (Fig. 16). Measure the oil level 2-3 min after shutting down a warmed-up engine.

Drain oil from the engine crankcase right after the end of the trip when the oil is still hot. This insures rapid and complete drainage of oil.

For removing the oil filter 10 (Fig. 17), rotate it counter-clockwise. When installing a new filter, make sure, that the rubber sealing ring is in serviceable condition, lubricate it with motor oil, and screw in the filter by hand till the sealing ring would contact with the cylinder block surface, then draw up tight

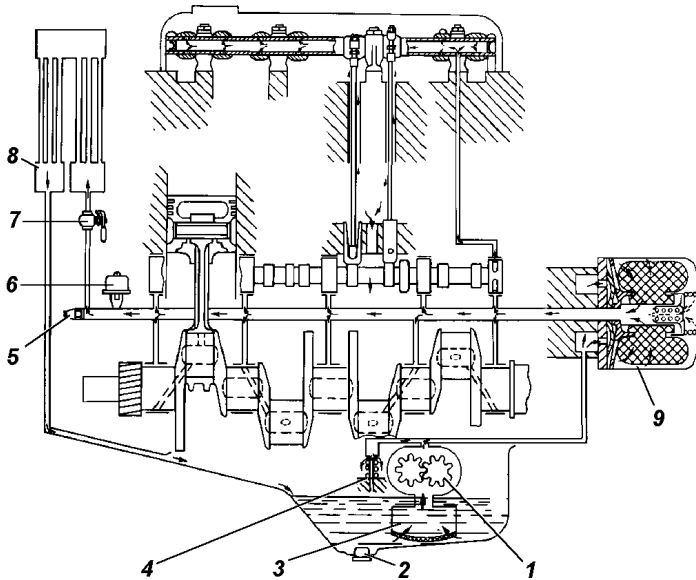

Fig. 22. Engine lubrication diagram:

1-oil pump; 2 -oil sump drain plug; 3 -oil intake strainer; 4-pressure relief valve;
 5 -low oil pressure warning lamp transmitter; 6 -oil pressure gauge transmitter;
 7 -oil cooler cock; 8 -oil cooler; 9 -full-flow oil filter

the filter through 3/4 of turn. Make sure, that there is no leakage of oil.

Oil pressure in the lubrication system of a warmed-up engine of a new automobile at a speed of 60 km/h in direct gear and when the oil cooler cock is open should be at least 343 kPa (3.5 kgf/cm²). Oil pressure in a cold engine can be increased to 588 kPa (6kgf/cm²), and on a hot summer day it could be dropped to 294 kPa (3kgf/cm²). Stop running the engine, when oil pressure is dropped to 118 kPa (1.2 kgf/cm²). When driving the automobile, watch the functioning of the oil pressure transmitters. The low oil pressure warning transmitter must operate at an oil pressure drop in the system down to 39-78 kPa (0.4-0.8 kgf/cm²).

The low oil pressure warning lamp may light when the hot engine is running at an idling speed, but the lamp must go out immediately with an increasing crankshaft speed.

Immediately stop running the engine if some faults in the engine lubrication system are detected.

Maintenance of the Crankcase Ventilation System

For flushing and cleaning, remove the vacuum regulator from the engine and disassemble it. Clean the pipelines (Fig. 23), the calibrated orifice "b" (Fig. 24) and flush the parts of the vacuum regulator.

Check tightness between the case and cover plate when assembling the vacuum regulator.

Maintenance of the Fuel System

Fuel tanks. To wash the fuel tanks, remove them from the automobile. Flush the fuel tanks with clean gasoline.

Fuel filter-settler. Periodically drain sediment and water through the drain hole stopped with a plug 8 (Fig. 25).

To remove the filter element for washing, unscrew the unions

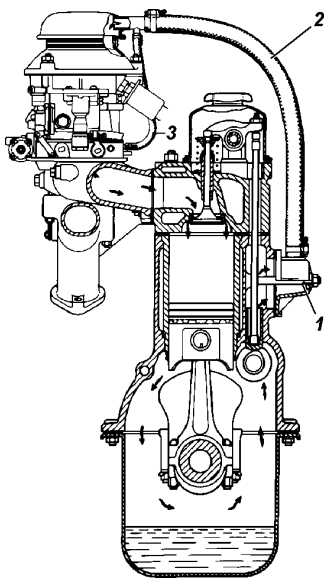

Fig. 23. Crankcase ventilation:
1 -oil baffle; 2,3 -pipes

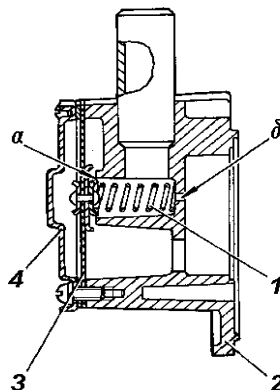

Fig. 24. Vacuum regulator:
a -valve seat; b-orifice
1 -spring; 2 -body; 3 -diaphragm;
4 -cover

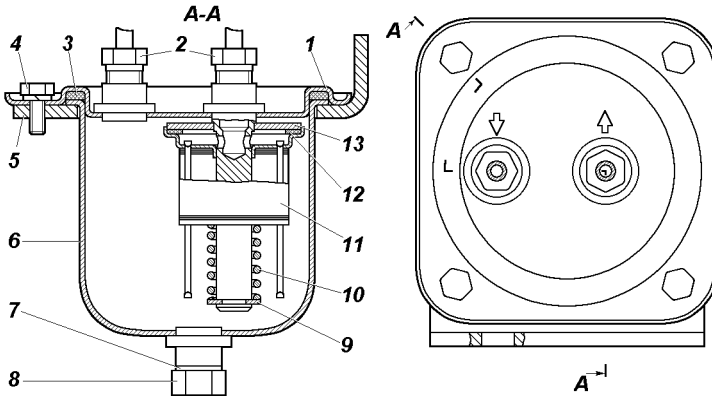

Fig. 25. Fuel filter-settler:

1 -cover; 2 -pipe unions; 3, 7, 12 -gasket; 4 -bolt; 5 -bracket; 6 -settler body; 8 -drain plug; 9, 13 -washer; 10 -spring; 11 -filter element

2 and bolts 4. Do not disassemble the filter element. After washing, blow out the filter element with compressed air at a pressure not in excess of 98 kPa (1kgf/cm²).

Fuel pump. Periodically check the fuel pump through the inspection hole "a" (Fig. 26) for leakage of fuel. Leakage of fuel indicates, that the diaphragm is faulty.

Periodically check the attachment of the pump to the engine and the connections of the pipelines for tightness. Flush the gauze strainer and remove dirt from the upper casing.

Fine fuel filter (refer to Fig. 16) Periodically disassemble the fine fuel filter for flushing the bowl and filter element.

Carburettor. The carburettor K-151B is installed on the engine 4178, and the carburettor K151E is installed on the engine 4218. The carburettors are identical in design, except for some jets. The main jets are indicated in the Appendix 3.

Maintenance of the carburettor includes periodic checks and adjustment of fuel level in the float chamber, adjustment of the crankshaft slow idling setting, check of the acceleration pump and economizer for functioning, cleaning, blowing and washing of the carburettor parts to remove gum residue, capacity checks of jets.

Check fuel level in the carburettor with the automobile placed on a level ground and the engine stopped.

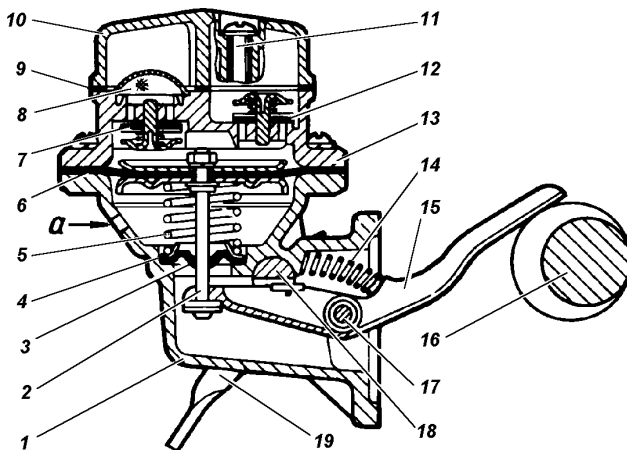

Fig. 26. Fuel pumps of Б9В type*:

a -inspection hole

1 - casing; 2 - pull rod; 3 - seal; 4 - washer; 5, 14 -springs; 6 - diaphragm; 7 - discharge valve; 8 - gauze strainer; 9 - gasket; 10 - cover; 11 - screw; 12 - exhaust valve; 13 -upper casing; 15 - rocker arm; 16 - camshaft eccentric; 17 - rocker arm shaft; 18 - hand primer lever shaft; 19 - hand primer lever

* The pumps 2105-1106010-50 or 900-1106010 could be also installed

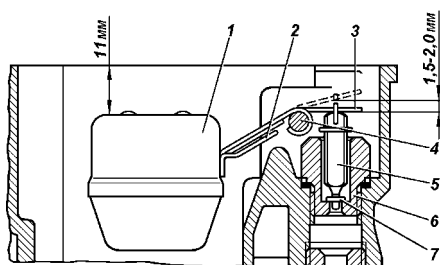

Fig. 27. Carburettor float and its adjustment:

1 -float; 2 -fuel valve adjustment lip; 3 -level adjustment lip; 4 -pin; 5 -valve needle; 6 -valve body; 7 -valve washer

The fuel level in the carburettor float chamber should be within 20-23 mm from joint plane of the float chamber. Adjust the fuel level by bending lip 3 (Fig. 27). The float should be in the horizontal position. The valve 5 stroke is adjusted by means of the lip 2 and should be 1.5 - 2.0 mm.

Slow idling speed of the crankshaft at 700-750 min^{-1} is to be adjusted by means of the screw 1 (Fig. 28) when the engine is

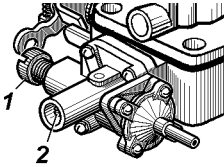

Fig. 28. Carburettor (fragment):
1 -idle speed adjustment screw; 2 -idle mixture adjustment screw

warmed up. The screw 2 is used for adjusting the CO content. After adjustment done, place on the adjustment screw a new cap, that the content of mixture could be only leaning (by screwing in the cap). It is recommended to adjust the screw 2 only by special tools for analysing of exhaust gases.

Air cleaner. When the automobile is to be operated under very dusty conditions, carry out the maintenance of the air cleaner in the intervals between servicing according to Coupons.

Do not clean the filter element more than 15 times. For cleaning, use the following ways: wash the filter element with water adding syntetic washing agent and then rinse it, wring gently out and dry; blow it out or clean by shaking off.

For replacing or cleaning the filter element, proceed as follows: loosen bolts 8 (Fig. 29) and yoke 2; shift clamps 9; take away cover 6 with filter element 5; take away yoke 10 and filter element from frame. Assembly the air cleaner in the reverse order.

Never use the air cleaner with defective muff 1.

Replace the filter element when bursting or burning the filter

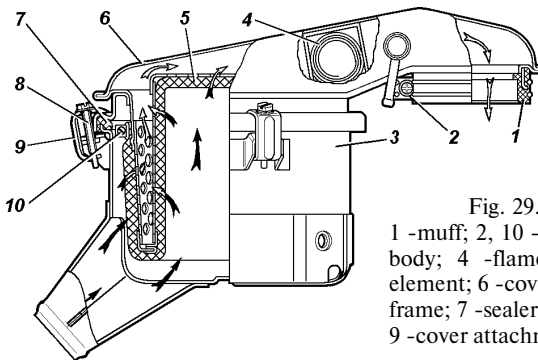

Fig. 29. Air cleaner:
1 -muff; 2, 10 -yokes; 3 -air cleaner body; 4 -flame damper; 5 -filter element; 6 -cover with filter element frame; 7 -sealer; 8 -contracting bolt; 9 -cover attachment clamp

element, every 100 000 km of run, after maximum permissible procedures of cleaning.

Flush the gauze 4 of the flame trap with one of the dissolvents: kerosene, turpentine, white spirit.

Inlet manifold. During seasonal maintenance, set the manifold heat-control valve (Fig. 30) to the position corresponding to the coming season of the year.

Accelerator pedal. While in service, it may become necessary to adjust the carburettor throttle full opening and readjust the accelerator pedal position.

Adjust the throttle full opening and the pedal position by turning the lever 4 (Fig. 31) on the pedal shaft. For adjustment, carry out the following: disconnect the spring 11, release the locknut 5 on the pedal shaft, set the pedal against the stop to the toeboard (the position corresponding to the throttle full opening). Holding the lever 4 in the position of the throttle full opening,

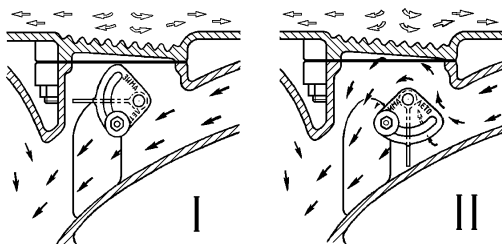

Fig. 30. Manifold heat control valve:
I - heat control valve OFF (summer);
II - heat control valve ON (winter)

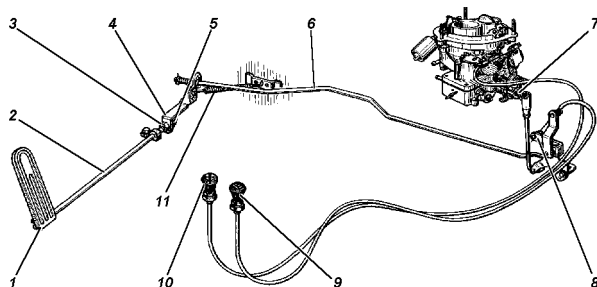

Fig. 31. Carburettor control linkage:

1 - accelerator pedal; 2 - pedal shaft; 3 - nut; 4 - shaft lever; 5 - locknut; 6 - accelerator shaft rod; 7 - throttle lever; 8 - rod lever; 9 - throttle rod knob; 10 - choke rod knob; 11 - return spring

tighten up the locknut, connect the spring. The adjustment is over, if the throttle is fully closed with the pedal released, and the throttle is fully open with the pedal pressed all the way down.

If required, lubricate the cables of the throttle and choke manual control with grease. To do that, remove them from the automobile and remove the old grease.

Maintenance of the Engine Cooling System

The engine cooling system (Fig. 32) is filled with coolant simultaneously with the heating system.

Low-freezing fluid ОЖ-40 "Лена" or ТОСОЛ-А40М is used as a coolant.

At ambient air temperatures below -40°C , fill the system with low-freezing fluid ОЖ-65 "Лена" or ТОСОЛ-А65М.

If the above-mentioned grades of coolant are not available, You may use other coolant recommended by the automobile dealer.

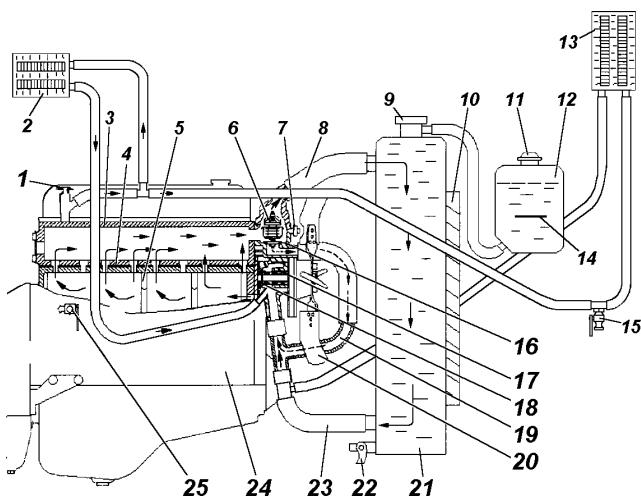

Fig. 32. Engine cooling system:

1 -heater cock; 2 -passenger compartment heater radiator; 3 -cylinder block head; 4 -gasket; 5 -coolant channels between cylinders; 6 -two-valve thermostat; 7 -coolant temperature gauge transmitter; 8 -exhaust manifold; 9 -filler neck; 10 -shutter; 11 -plug; 12 -expansion tank; 13 -cab heater radiator; 14 -"min" mark; 15 -heating system drain cock; 16 -thermostat body; 17 -pump; 18 -impeller; 19 -connection pipe; 20 -fan; 21 -radiator; 22 -radiator drain cock; 23 -inlet manifold; 24 -cylinder block; 25 -cylinder block drain cock

Bear in the mind that antifreeze is poisonous.

The coolant level should be 30-40 mm above the MIN level mark inscribed on the expansion tank.

Never mix the coolants of different grades. If the level of special fluid in the system has dropped and fluid of the same grade is not available, top up the system with clean soft rainy, snow or boiled water.

Bear in mind that the freezing point of the antifreeze diluted with water is higher. Fill the system with antifreeze of appropriate grade at the first opportunity.

If the special coolant is not available, it is permissible to use clean soft water. In this case, at the ambient temperature below 0 °C proceed as follows:

- disconnect the hose from the expansion tank and lower it to carry off steam from the radiator;
- when parking, drain coolant from the engine cooling system and heating system.

Keeping the coolant temperature in a range of 80 to 90 °C during operation of the automobile considerably decreases wear of the engine and cuts down fuel consumption. The recommended temperature is maintained by means of an automatically operated thermostat and the shutters controlled by the automatically operated thermostat and the shutters controlled by the driver.

In cold weather, we recommend to encase the cooling system for warmth-keeping.

The coolant temperature gauge located on the instrument panel controls the temperature of coolant.

Besides this, the lamp with red light filter warns of coolant overheating. The lamp goes on at the coolant temperature between 91 and 98 °C for automobiles operating in regions with temperate climate, and at the coolant temperature between 102 and 109 °C for automobiles operating in regions with tropical climate. When lighting the coolant temperature overheating warning lamp, immediately determine and eliminate the cause of overheating.

The rise of the coolant temperature may be caused by the drop of coolant level in the radiator, loose tension of the fan belt, faulty fan drive coupling, by movement of the automobile with the closed shutters and with the closed valve of warmth-keeping boot.

Adjust deflection of the fan belt (Fig. 33) by turning the alternator. Normal deflection of the belt equals 8-14 mm with an effort of 4 kgf (39 N) applied to it.

When using water as a coolant, periodically remove from the cooling system scale and dirt by flushing them with a fast jet of clean water. Flush the engine separately from the radiator so that rust, scale and sediment from the engine cooling jacket do not clog the radiator (Fig. 34). Prior to flushing the engine, remove the thermostat.

Drain coolant from the cooling system through two cocks. One of them is arranged on the radiator lower reservoir, the other on the cylinder block. When draining the coolant, remove the radiator cap and open the cock.

When draining the coolant from the engine cooling system, drain also the fluid from the heating system through the cock 15 (Fig. 32) located on the inlet manifold of the cab heater radiator. Access to the cock is from the front, from below of the automobile.

Notes.

1. On some automobiles, the engines 4178 are installed, with feeding coolant to cylinder head completed with the pump of the cooling system in which design the ball bearings are applied.

2. On some automobiles, the visco coupling of the fan drive is installed, its purpose is to reduce fuel consumption, fan noise. It also reduces the time required for cold engine warm up and maintains the engine efficient operating condition. Keep the outer surface of the coupling clean.

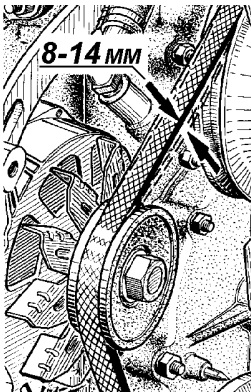

Fig. 33. Checking fan belt tension

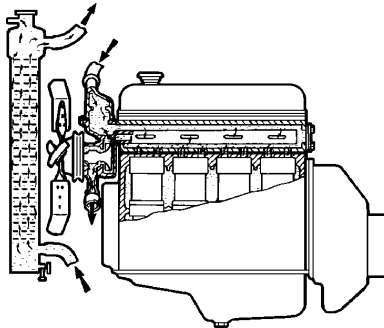

Fig. 34. Flushing cooling system

Maintenance of the Ignition System (Fig. 35)

If the transistor switch or the coil of the magnetic pulse distributor stator failed en route, change over to operation with the emergency vibrator for which purpose, disconnect the wire from the terminal K3 of the transistor switch and connect it to the terminal of the emergency vibrator.

Service life of the emergency vibrator is limited to 30 h, therefore switch it into operation only in emergency cases and replace a faulty unit at the first opportunity.

Simultaneously, when switching into emergency operation, switch off the system of idling-speed economizer for which purpose, connect by means of one of the hoses unions 1 and 2 (Fig. 36) of the carburettor between themselves missing the electromagnetic valve. Otherwise, the engine could be stopped when the throttle pedal is released fully.

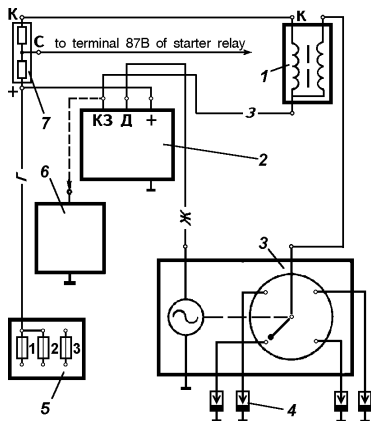

Fig. 35. Diagram of transistor ignition system:

- 1 -ignition coil; 2 -transistor switch;
- 3 -pickup-distributor; 4 -spark plug;
- 5 -fuse unit; 6 -emergency vibrator;
- 7 -series resistor

Wire color code:

Г -blue; K -red; Ж -yellow; 3 -green

Fig. 36. Housing of carburettor mixing chambers :
1 -economizer union; 2 -sole-noid valve vacuum supply union;
3 -union for vacuum supply to vacuum spark advance control

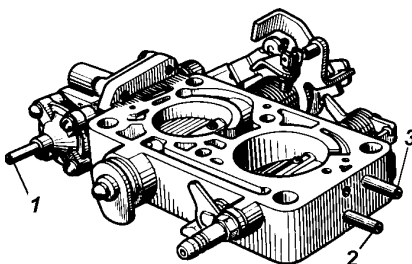

After restoring the contactless ignition system (replacing of the magnetic pulse distributor or transistor switch), restore the previous connections of the carburettor.

Maintenance of the system consists in setting the ignition timing, regularly cleaning the rotor and cover of the magnetic pulse distributor, high-voltage part of the ignition coil and spark plugs, in timely lubricating the magnetic pulse distributor and checking spark gap.

Check spark plug gap with a feeler gauge (Fig. 37). The gap should be equal to $0.8^{+0.15}$ mm. Adjust the gap by bending the side electrode.

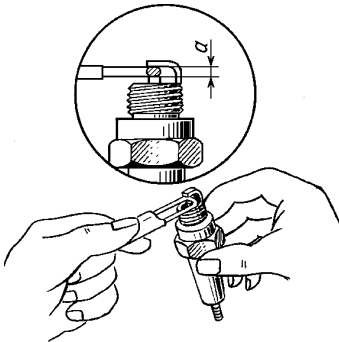

Fig. 37. Checking spark gap:
a -gap

For setting the ignition timing, proceed as follows:

1. Set the piston of No. 1 cylinder at the TDC on the compression stroke until the timing hole on the crankshaft pulley gets in register with the timing pointer on the timing gear cover.

2. Remove the cap from the magnetic pickup.

3. Make sure that the contact segment of the runner is set against the cap terminal marked with numeral "1".

4. Loosen the bolt with the indicator, clamp the octane selector plate to the drive body so that the indicator is in register with the middle division mark of the octane selector scales, and tighten the bolt.

5. Loosen the bolt securing the octane selector plate to the magnetic pickup and distributor unit body (Fig. 38).

6. Holding the runner and forcing it clockwise (to take up the backlash in the drive), carefully turn the distributor body until

Fig. 38. Adjusting octane selector setting

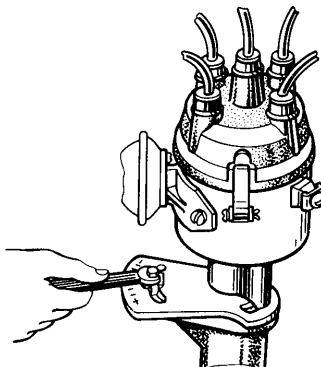

the red mark on the rotor is aligned with the index pointer on the stator. Using the bolt, secure the octane selector plate to the distributor body.

7. Reinstall the cap of the magnetic pickup and distributor unit and check to see that the ignition wires running to the spark plugs are set correctly in compliance with the engine firing order (1-2-4-3), counting counterclockwise.

Each time after setting the timing, check for correct spark timing by listening to the running engine, with the automobile in motion. To this end, warm the engine up to a temperature of 80 °C and while moving in the direct gear on a level road at a speed of 40 km/h, accelerate the automobile by sharply depressing the accelerator pedal. If a light and short-time detonation is heard before a speed of 55-60 km/h is reached, it means that the ignition timing is set correctly.

In case of a heavy detonation, turn the magnetic pickup and distributor unit body counterclockwise through 0.5-1.0 division on the octane selector scale. Each division of the scale corresponds to a change of the ignition timing by 4° in the degrees of the crankshaft angle. If the detonation was not heard at all, increase the ignition advance angle by turning the body of the magnetic pickup and distributor unit clockwise.

Note. To prevent the surface sparkover and burning through of the magnetic pickup and distributor unit cap, see that the shoes of the high-tension wires are completely seated in the cap terminal sockets. Never switch on the ignition if moisture is detected on the cap. Keep the plastic parts (cap, runner, low-tension terminal, sockets, etc.) clean.

Forbidden to keep the ignition on when the engine is not operating, and to disconnect the storage battery when the engine is operating

TRANSMISSION

Maintenance of the Clutch

The automobile is equipped with a dry single-plate clutch (Fig. 39) provided with the pressure plate 4 with the cover plate 20, pressure springs 19 and release levers 11 in assy, driven disk 3 with linings and torsional vibration damper in assy.

Some automobiles are equipped with a dry single-plate clutch provided with the central pressure spring of the diaphragm type. The clutch consists of the pressure plate with the cover plate and of the pressure disk diaphragm spring which tabs function as release levers; driven plate with linings and torsional vibration dampers.

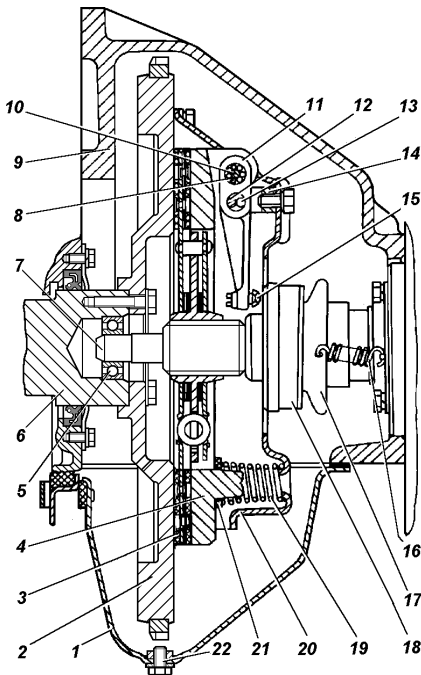

Fig. 39. Clutch:

- 1 -clutch housing lower part;
- 2 -flywheel; 3 -driven disk;
- 4 -pressure plate; 5 - front bearing; 6 -crankshaft; 7 - input shaft; 8 -needle bearing; 9 -clutch housing; 10 - release lever pin; 11 -release lever; 12 -release pin; 13 -release roller; 14 -release lever fork; 15 -adjusting screw; 16 -retracting spring; 17 -clutch release sleeve; 18 -clutch release bearing; 19 -pressure spring; 20 - clutch housing; 21 -heat insulating washer; 22 -plug

A grease cup for the clutch release bearing identifies visually the clutch type. The clutch with the pressure springs and release levers is provided with the grease cup to be found on the right-hand side of the engine (in motion). The clutch with the central diaphragm pressure spring is not provided with a grease cup.

Maintenance of the clutch consists in cleaning of dirt, tightening the bolt joints, adjusting and lubricating the clutch release bearing.

The clutch release bearing with the central diaphragm spring needs no grease.

Periodically drain condensate from the clutch housing unscrewing the plug 22 (Fig. 39).

Maintenance of the clutch control linkage amounts to adjustment of the pedal free travel, to periodical checks on the level of fluid in the reservoir of the clutch hydraulic system master cylinder and to bleeding the hydraulic system if required*.

The level of fluid should be 15-20 mm below the upper edge of the reservoir.

Perform adjustment of the clutch release pedal by changing the length of the master cylinder pushrod 2 (Fig. 40).

Perform adjustment of the pedal free travel (35-55 mm) by changing the length of the slave cylinder 9 pushrod 12.

The clutch with the central diaphragm spring needs no adjustment of free travel. The free travel (5-30 mm) is maintained by the clutch design.

Maintenance of the Gearbox

Maintenance of the transmission consists in checking the oil level (Fig. 41), in changing the oil at established intervals specified in Lubrication Table and in periodically checking the joints for proper fastening and in adjusting the control linkage.

For adjusting the control linkage, change the length of horizontal rods 8, 11 (Fig. 42) and vertical rods 5, 14.

Prior to adjustment, set the shift lever 9 in the neutral position and the selector lever 10 in the position III-IV until it rests

*All the operations of bleeding the clutch hydraulic system are similar to operations of bleeding the hydraulic brake system (refer to section "Maintenance of the Service Brakes")

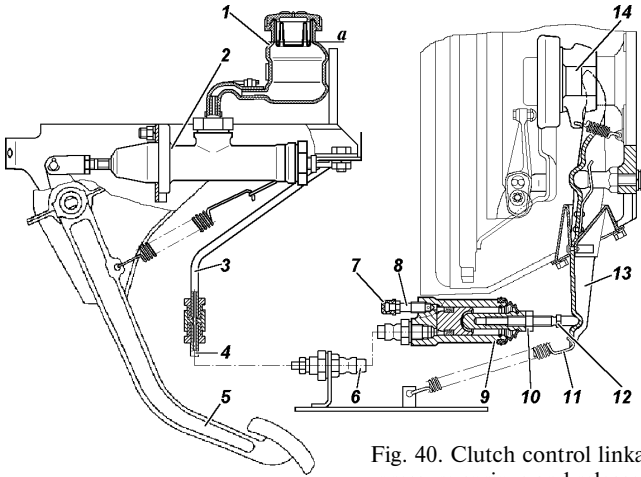

Fig. 40. Clutch control linkage with pressure springs and release levers:
a - fluid level

1 -reservoir; 2 -master cylinder; 3, 4 - pipelines; 5 -pedal; 6 -hydraulic hose; 7 -protective cap; 8 -by-pass valve; 9 -slave cylinder; 10 -locknut; 11 -spring (is not installed to couple with centre diaphragm pressure spring); 12 -pushrod; 13 -fork; 14 -coupling

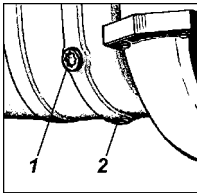

Fig. 41. Gearbox plugs:
1 -filler hole plug;
2 -drain hole plug

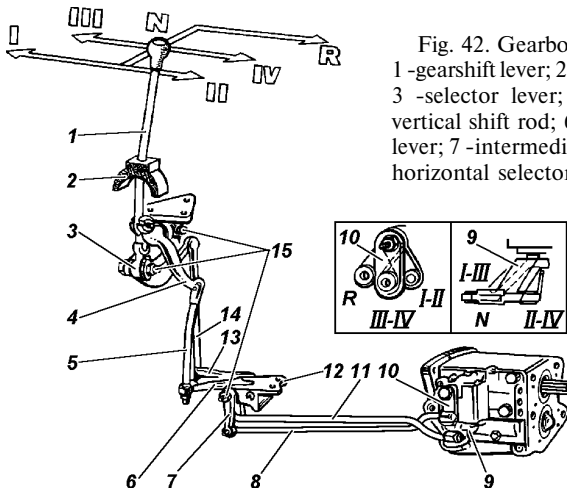

Fig. 42. Gearbox control linkage:
1 -gearshift lever; 2 -gearshift lever boot;
3 -selector lever; 4 -shift lever; 5 -vertical shift rod; 6 -intermediate shift lever; 7 -intermediate selector lever; 8 -horizontal selector rod; 9 -shift lever;

10 -selector lever; 11 -horizontal shift rod; 12 -intermediate bracket of levers; 13 -intermediate selector lever; 14 -vertical selector rod; 15 -grease fitting

against the spring of the reverse gear interlock. Loosen all the nuts intended for regulating the length of rods.

Set the gearshift lever 9 in the middle position between gears III and IV. In this position, connect and secure selector rods 8 and 14 taking care to avoid pulling on the levers or rods. This done, set the gearshift lever 1 in the neutral position between gears III and IV, and connect the shift rods 5 and 11.

Upon adjustment, check to see whether the gears are properly shifted in. To this end, shift in the first gear (with the clutch disengaged) and check to see that the control linkage rods and levers are not resting against the adjacent parts. Repeat the same check with the reverse gear shifted in. In this case, check to see that the intermediate shift lever 6 does not rest against the frame cross member and the front swivel splash guard when the latter is opened. There should be a clearance of 2-3 mm between them when the reverse gear is shifted in.

Maintenance of the Transfer Box

Maintenance of the transfer box in service comes to checking the oil level and changing oil at intervals specified in Lubrication Table, and also to checking periodically all attachment parts.

When changing or refilling oil in the transfer box, check simultaneously the level of oil in the gearbox. The level of oil should reach the lower edge of the check holes 1 (Fig. 41, 43).

During operation of the automobile, the level of oil in the gearbox could be lowered to 8 mm relatively the lower edge of the check hole 1 (Fig. 41), and simultaneously it could be raised in the transfer box. In this case, it is no need to level the grease levels.

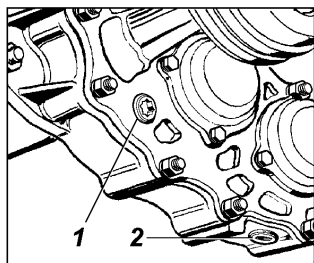

Fig. 43. Transfer box plugs:
1 -filler hole plug;
2 -drain hole plug

Maintenance of the Propeller Shafts

Periodically check tightening of the bolts attaching the propeller shaft flanges, periodically lubricate them, clean the propeller shafts of dirt.

Lubricate the splined joint through the grease fitting 1 (Fig. 44) screwed in the slip yoke, and the needle bearings are lubricated through the grease fittings 2 on the centre cross.

Lubricate the needle bearings until grease is shows up from under the working edges of the centre cross seals.

Apply grease according to the directions of Lubrication Table.

Do not apply too much grease to the splined joint as it would bleed through the splined joint and that would provoke the preliminary failure of the seals and could force the plug of the slip yoke.

Use a special tip to be fitted on the grease gun to lubricate the propeller shaft. The tip is available in the driver's tool kit.

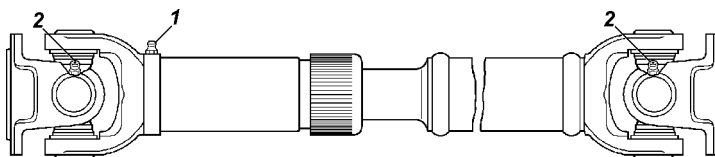

Fig. 44. Rear propeller shaft:

1 -grease fitting for lubricating of splined joints; 2 -grease fitting for lubricating of joint needle bearings

Maintenance of the Rear Axle

Maintenance of the rear axle comes to maintaining the level of oil in the housing and its timely changing, checking the condition of the seals. Periodically clean the safety valve 1 (Fig. 45), tighten up all fastening parts.

Apply grease according to the directions of Lubrication Table.

Check the oil level which should reach the edge of the filler hole.

Drain oil through the hole at the bottom of the housing by screwing out the filler plug.

Check also the level and change oil in the hub drive housings when the axles are provided with the hub drives.

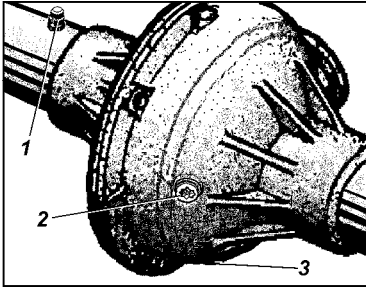

Fig. 45. Rear axle:
1 -safety valve; 2 -filler hole plug;
3 -drain hole plug

Maintenance of the Front Axle

All the directions on maintenance of the rear axle are valid for the front axle.

Maintenance of the steering knuckles should be carried out additionally.

Lubricate the steering knuckle kingpins through the grease fitting 10 (Fig. 46) according to directions of Lubrication Table. When inspecting the steering knuckles of the front axle, check to be sure that the adjusting bolts 27, the steering stop 28 are in serviceable condition and are reliably locked with the nut.

The front driving axle is provided with a device for disengagement of the front wheels (Fig. 46 III).

For disengaging the front wheels, remove hub cap 21 and by screwing out the bolt 19 set coupling 18 in position in which a circular indicating groove "a" on the surface of coupling is arranged in one plane with the face of flange 17 (Fig. 46, view III). Having set coupling 18 in a required position, screw on hub cap 21.

For engaging the wheels, screw in bolt 19 as far as it will go. Be sure to engage and disengage both front wheels.

Some automobiles could be equipped with a sleeve for disengagement of the front wheels, shown in Fig. 46 IV. For disengaging the wheels, turn the disk of the sleeve counterclockwise as far as it will go arranging in one plane the mark "6" with the figures "4x2". For engaging the wheels, turn the disk of the sleeve clockwise as far as it will go arranging in one plane the mark with the figures "4x4".

Never engage the front axle when the front wheels are disengaged.

Fig. 46. Steering knuckle:

I -r.h. steering knuckle; II -l.h. steering knuckle; III -wheel disengaging coupling; a -indicating groove; IV -wheel disengaging coupling; 6-pointer;

1 -steering knuckle cover plate; 2 -axle shaft sleeve; 3,27 -seals; 4 -steering arm rod; 5 -gasket; 6 -ball support; 7 -steering knuckle housing; 8 -steering knuckle lever; 9 -kingpin; 10 -grease fitting; 11 -set pin; 12 -circlips; 13 -journal; 14 -wheel hub; 15 -gasket; 16 -lock washer; 17 -driving flange; 18 -coupling; 19 -coupling bolt; 20 -lock ball; 21 -protective cap; 22 -nuts; 23 -bolt; 24 -thrust washer; 25 -hub bearings; 26 -spacing ring; 28 -lower cover plate; 29 -thrust washer; 30 -kingpin bushing; 31 -adjusting shims; 32 -seal internal ring; 33 -partition-ring; 34 -seal external ring; 35 -inner sealing ring; 36 -outer sealing ring; 37 -thrust washers; 38 -joint; 39 -steering stop adjusting bolt; 40 -steering stop; 41 -steering rod; 42 -wheel disengaging coupling disk

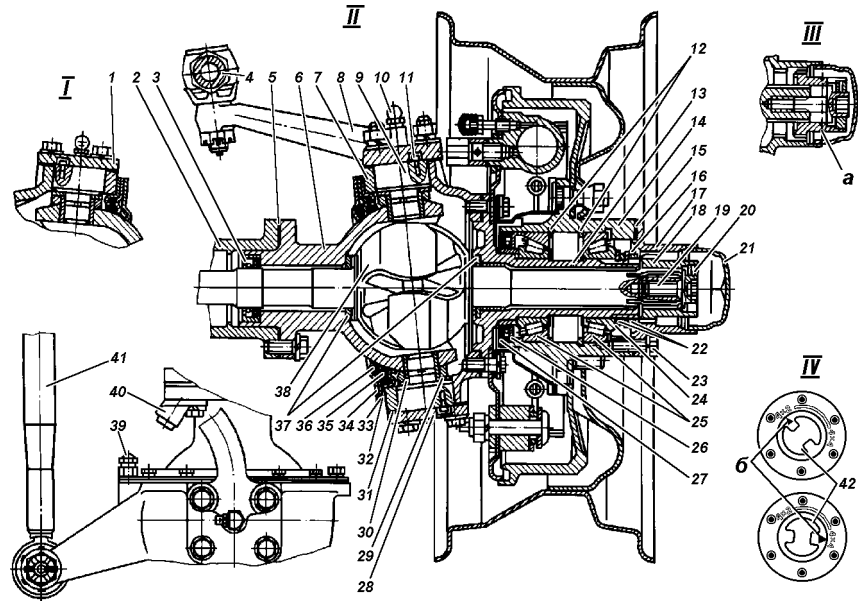

CHASSIS

Towing Hook

The towing hook is intended for towing a trailer or an automobile by means of flexible coupling, and also it allows a short-time operation by means of rigid coupling. Towing of a trailer on a broken ground is not allowed.

The hook is provided with a catch 3 (Fig. 47) which closes the mouth of hook and is locked in the closed position by means of the pawl under the action of the spring.

The pawl in the catch is closed by a cotter 4 to avoid spontaneous uncoupling.

Maintenance of the towing hook comes to periodically cleaning of dirt, checking it for reliable attachment to the rear cross-member and lubricating according to the directions of Lubrication Table.

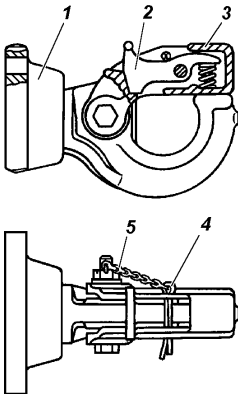

Fig. 47. Towing gear of rigid type:
1 -case; 2 -pawl; 3 -catch; 4 -cotter pin; 5 -chain

Maintenance of the Suspension

Periodically check the condition and attachment of the springs and shock absorbers (Fig. 48). To prevent corrosion and eliminate squealing noise, lubricate the spring leaves at least once a year. To lubricate the springs, remove them from the automobile, disassemble, wash in kerosene, dry and lubricate each leaf with a grease according to Lubrication Table.

Squeaks in the spring eyes are symptoms of worn-out rubber pads.

When installing the springs, carry out the last tightening of the U-bolt nut on the automobile standing on the wheels.

Maintenance of the shock absorbers consists in periodically checking them for tightness and reliable fastening, as well as in changing the fluid in compliance with the instructions laid down in Lubrication Table.

If leakage of fluid through the rod seal and the reservoir sealing rings is detected, tighten nut 18 (Fig. 49). If the leakage fails to be eliminated, repair the shock absorber in a workshop.

Change fluid in the shock absorbers every 100 000 km of run.

Wheels, Tyres

The spare wheel attachment is shown in Fig. 50.

The spare wheel should be secured properly on the carrier by means of the sector 2 (Fig. 50, A) or bracket 7 (Fig. 50, B).

To avoid burns of the tyre by the exhaust pipe before securing the spare wheel, move the spare wheel from the exhaust pipe until a clearance of not less 40 mm is reached.

When maintaining, inspect the wheels and tyres for proper condition, check the wheel attachment nuts for tightening and the tyre inflation pressure.

To provide for uniform tightening of the nuts, tighten them alternately, every second one.

Before every run, check the condition of tyres and eliminate detected defects. Periodically check the tyre inflation pressure and bring it to normal, if required.

Check inflation pressure in cold tyres.

If an uneven wear of the front wheel tyres is detected, check and adjust the toe-in of the front wheels.

With the normal tyre inflation pressure the toe-in of the front wheels should be such that the dimension "A" (Fig. 51) measured by the center line of side surface of the tyres ahead of the axle is 1.5-3.0 mm less than the dimension "B" measured back of the axle. As required, adjust the toe-in of the front wheels by changing the length of the steering tie rod; then, having loosened locknuts 1 and 3 provided with the right- and left-hand thread, rotate adjusting sleeve 2 (Fig. 52) to set a required value of the toe-in. Upon adjustment, tighten the locknuts. To provide uniform wear of tyres, carry out tyre rotation as a preventive treatment.

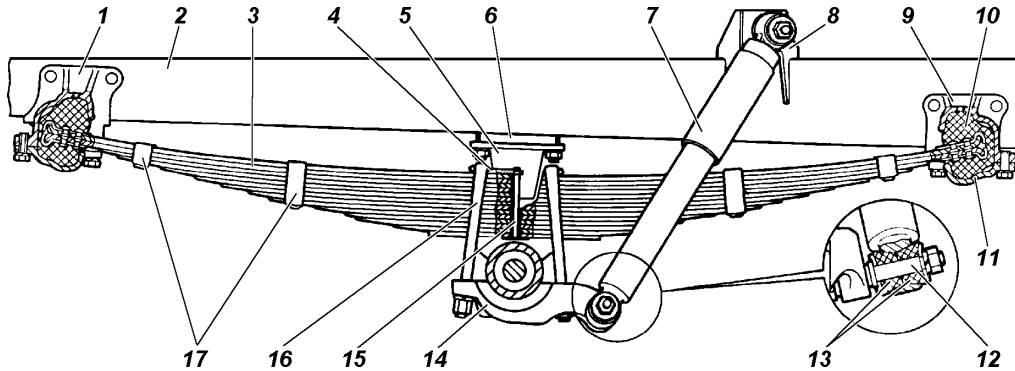

Fig. 48. Front suspension:

1 -spring front hanger; 2 -frame; 3 -spring; 4 -cover plate;
 5 -buffer; 6 -buffer liner; 7 -shock absorber; 8 -shock
 absorber bracket; 9 -spring rear hanger; 10 -rubber pad;
 11 -bracket cover; 12 -shock absorber pin; 13 -rubber
 bushings; 14 -U-bolt liner; 15 -contracting bolt; 16 -U-
 bolt; 17 -yokes

Note. Rear suspension design is the same

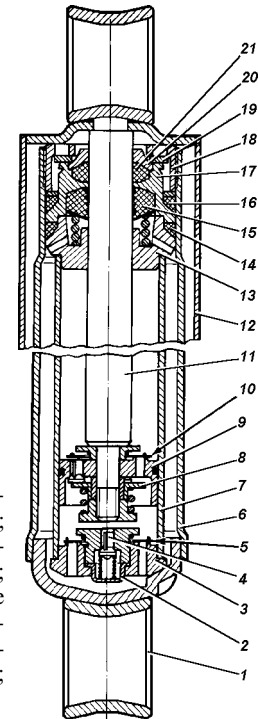

Fig. 49. Shock absorber:

1 -eye; 2 -compression valve stop; 3 -com-
 pression valve body; 4 -compression valve;
 5 -intake valve; 6 -reservoir; 7 -cylinder; 8 -
 rebound valve; 9 -piston; 10 -by-pass valve;
 11 -rod; 12 -dust shield tube; 13 -rod guide
 bushing; 14 -lower sealing ring; 15 -seal; 16 -
 upper sealing ring; 17 -seal holder; 18 -
 reservoir nut; 19 -washer; 20 -protective ring;
 21 -rod seal

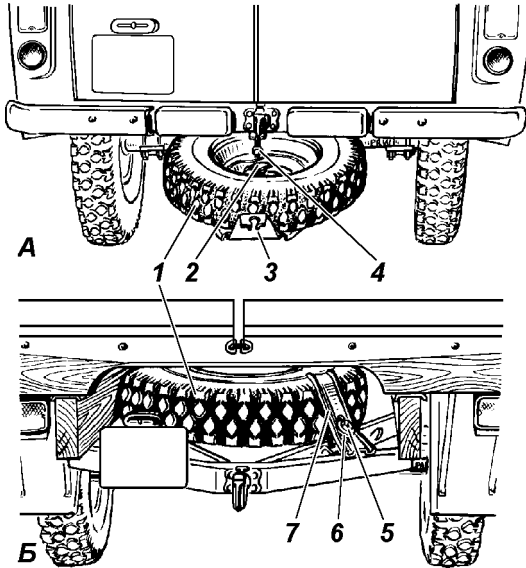

Fig. 50. Spare wheel attachment:

A - automobiles YA3-3741, YA3-3962, YA3-3909, YA3-2206, YA3-33036, YA3-39094, YA3-39095;

Б - automobile YA3-3303;

1 -spare wheel; 2 -sector; 3 -carrier; 4 -nut; 5 -bolt; 6 -washer; 7 -bracket

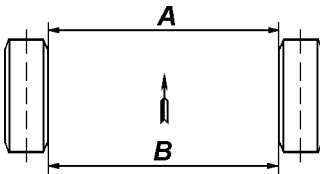

Fig. 51. Wheel toe-in

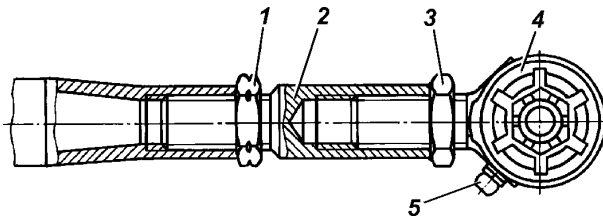

Fig. 52. Steering rod end :

1 -locknut with l.h. thread; 2 -adjusting sleeve; 3 -locknut with r.h. thread; 4 - joint; 5 -grease fitting

When rotating the cross-ply tyres, introduce the spare wheel tyre into the rotation if its wear does not differ from wear of the other tyres (Fig. 53).

When rotating the radial-ply tyres, rotate the front and rear wheel tyres separate for each side. Do not introduce the spare wheel tyre.

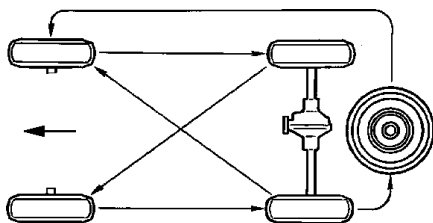

Fig. 53. Tyre rotation diagram

Wheel Hubs

The hubs of all the automobile wheels are the same.

Maintenance of the wheel hubs consists in checking the wheel hub bearings for tightening and, if required, in their adjusting, in checking the fasteners of the axle shaft flanges and hub driving flanges.

Rock a jacked-up wheel to detect play in bearings.

Pay special attention to correct adjustment of the wheel hub bearing on a new automobile.

Change grease in compliance with Lubrication Table. For changing grease, remove the hub from the spindle, remove old grease and thoroughly wash the bearings and lubricate them. Apply 10-15 mm grease between the bearings. Do not apply too much grease to the hubs to avoid its ingressing in the wheel brakes.

Adjust the wheel hub bearings in the following sequence:

1. Jack up the wheel whose bearings are to be adjusted.
2. Take out the rear axle axle shaft 5 (Fig. 54) or remove the hub driving flange and the front axle wheel disengaging coupling.
3. Unbend the tab of the locking washer 7, turn off the locknut 6 and remove the locking washer.
4. Back off the bearing adjusting nut $1/6$ to $1/3$ turn (1-2 flats).

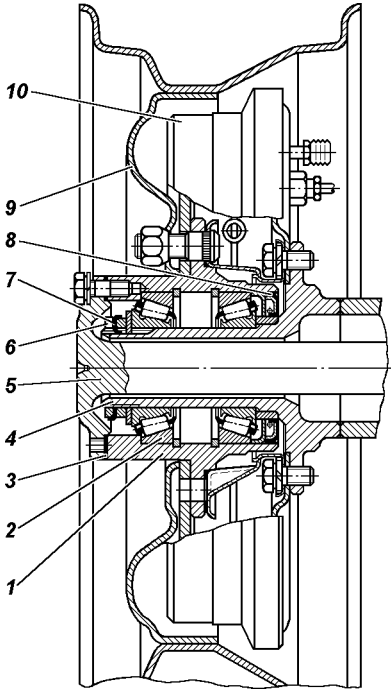

Fig. 54. Rear wheel hub:
 1 -hub; 2 -bearing; 3 -gasket; 4 -
 journal; 5 -axle shaft; 6 -locknut; 7
 -lock washer; 8 -collar; 9 -wheel
 disk; 10 - brake drum

5. Rotate the wheel by hand to check it for easy turning (the wheel should rotate freely without rubbing of the brake drum against the brake shoes).

6. Tighten the adjusting nut of the hub bearings with the aid of a wrench applying a hand effort to the wrench tommy bar 300-350 mm long until the wheel is rotated with difficulty (Fig. 55). When tightening the nut, apply the effort to the tommy bar smoothly without jerks and simultaneously rotate the wheel to allow the roller to assume correct position on races of the bearings.

7. Back off the nut 1/4 to 1/3 of a turn (1.5-2 flats) and install the locking washer, screw in and tighten the locknut.

Replace the washer if some cracks on the tabs of the locking washer are detected.

8. Check adjustment of the bearings after tightening the lock-nut. If the adjustment is correct, the wheel should rotate freely, without binding noticeable axial play and wobbling.

9. Bend the one tab of the lock washer round the flat of the

nut, bend the second tab round the flat of the locknut. (Fig. 56).

10. Reinstall the axle shaft of the rear axle or driving flange and front axle wheel disengaging coupling, install the spring washers and tighten the bolts.

After a run, check the wheel hub for correct bearing adjustment by its heating. If the hub overheats, back off the nut $1/6$ of a turn (1 flat), observing the above sequence and rules.

When checking the bearing adjustment by hub heating, do not apply the service brakes since the hubs will be heated from the brake drums.

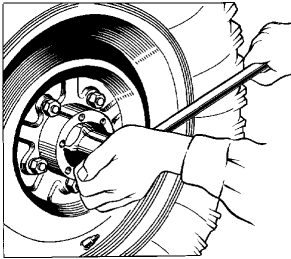

Fig. 55. Adjustment of hub bearings

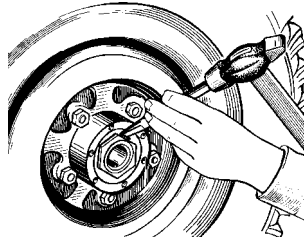

Fig. 56. Locking hub bearing nuts

CONTROL SYSTEMS

Maintenance of the Steering Gear

For maintenance of the steering gear, timely tighten up the bolts attaching the steering gear case to the bracket, check the pins of the steering rods the steering knuckle lever, steering arm for proper attachment. Check the steering wheel play, adjust the steering mechanism, lubricate timely the steering rod joints and add oil into the steering gear case (if required).

The steering rod joints are lubricated through the grease fitting 5 (refer to Fig. 52).

Periodically check the locknuts of the tie-rod tips for proper tightening. Do not allow any clearances in tapered joints of the levers and pins.

If radial play in the joint of the tie-rod tip is detected, turn off the plug 1 against the stop (Fig. 57), and then unscrew it by half-turn and in this position turn off it. If radial play is not eliminated, replace the tie-rod tip.

Periodically check the steering wheel play. The steering mechanism is considered to be in serviceable condition and needs no adjustment if the steering wheel play with the wheels set in a straight-ahead position is not over 10° under a force of 7.35 N (0.75 kgf) applied to a dynamometer which corresponds to 40 mm when measured on the steering wheel rim.

If the steering wheel play exceeds the above-mentioned value, then prior to adjustment of the steering mechanism, make sure that the bolts securing the steering gear case are properly tightened and the joints of the steering linkage are in serviceable condition.

Start the adjustment procedure by checking the worm bearings for axial play. To this end, grasp the steering column so that the thumb is in contact with the end face of the steering wheel hub and turn the steering wheel in either direction through a definite angle (Fig. 58). If the bearings are worn the axial play of the steering wheel hub relative to the steering column tube will be felt by the thumb. If there is no axial play of the worm, adjust only the meshing of the roller and worm.

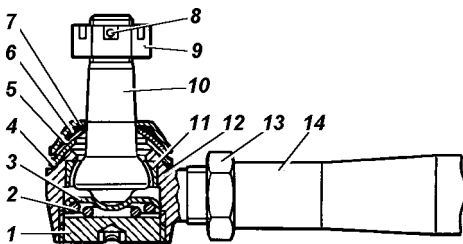

Fig. 57. Steering rod joint:

- 1 -plug; 2 -spring; 3 -pivot; 4 -lower spherical washer; 5 -upper spherical washer; 6 -protective ring; 7 -spring cap; 8 -cotter; 9,13 -nut; 10 -ball pin; 11 -block; 12 -end piece; 14 -rod

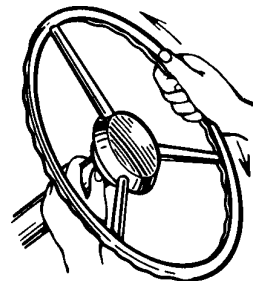

Fig. 58. Checking worm bearings for axial play

Brake Systems

Maintenance of the Service Brakes

Periodically check the fluid level in the brake master cylinder reservoirs 16 (Fig. 60) and top up if required. The level should be 15-20 mm below the filling hole upper edges. Make sure of the hydraulic brake system tightness. Check the pipelines for condition and reliable attachment to the frame and rear axle.

Do not operate the automobile when the pipes and hoses are faulty.

If one of the hydraulic brake circuits is a failure, the warning lamp on the instrument panel lights up.

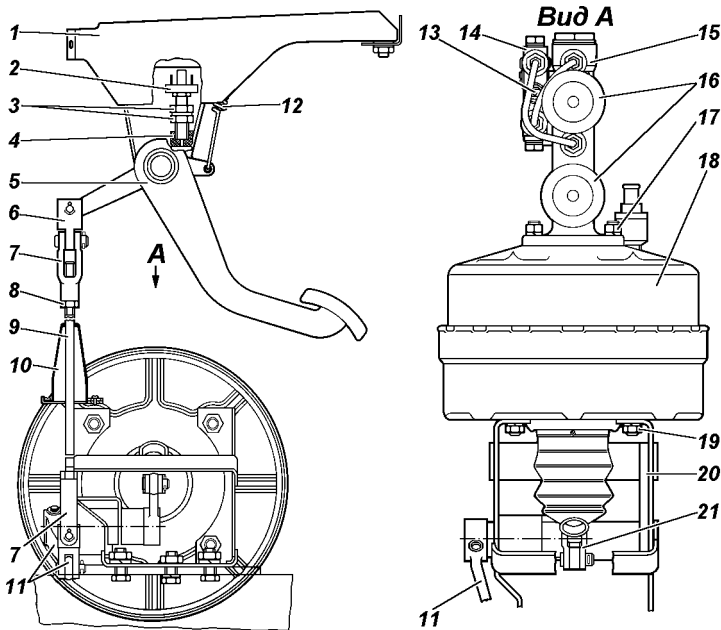

Fig. 60. Control linkage of brake master cylinder:

1 и 20 -brackets; 2 -stop-light switch; 3 -nuts; 4 -stop-buffer; 5 -brake pedal; 6 -intermediate fork; 7 -fork; 8 -locknut; 9 -rod; 10 -boot; 11 -intermediate lever; 12 -return spring; 13 -brake emergency warning lamp switch; 14 -emergency warning device; 15 -brake master cylinder body; 16 -reservoirs; 17 and 19 -nuts; 18 -brake vacuum booster; 21 -pushrod fork

Periodically remove the brake drums and clean the brake parts of dirt. Periodicity of this operation depends on service conditions of the automobile. In the summer season and when driving on mud-covered roads, carry out cleaning more frequently.

Keep a close watch on the brake system serviceability, timely perform its adjustment and eliminate detected faults.

For restoring the normal clearances between the brake shoes and drums and for reducing the brake pedal travel, adjust the brake drum-to-shoe in the following sequence:

1. Jack up the wheel which brake is to be adjusted.
2. Check the adjustment of the wheel hub bearings for correctness and carry out the adjustment, if required, as indicated in the section "Wheel Hubs".
3. Rotate the wheel and gradually turn the adjusting eccentric 19 (Fig. 61) or 4 (Fig. 62) until the wheel is braked.
4. While rotating the wheel, gradually back out the eccentric until the wheel starts rotating freely, without brushing of the drum against the brake shoes.
5. Similarly, adjust the drum-to-shoe clearances in the remaining brakes.

When adjusting the brakes of the front wheels and the front shoes of the rear wheel brakes, rotate the wheel forward. When adjusting the rear shoes of the rear wheel brakes, rotate the wheel backward.

For reducing the clearance, turn the eccentric in the direction of the wheel rotation and for increasing the clearance, rotate the eccentric in the reverse direction.

6. Make a road test to check the brakes for drum heating and for uniform application.

During the brake running adjustment, do not touch the anchor pins as the Manufacturer's setting of the brake shoes will be disturbed.

If the rivets of the linings are flush-mounted on a depth of less than 0.5 mm, replace the shoes or linings.

For adjusting the brake pedal free travel, change the length of the vertical rod 9 (Fig. 60). The brake pedal full travel is 200 mm. The brake pedal free travel must be 5-14 mm.

Check the brake pedal free travel when the engine is shut down.

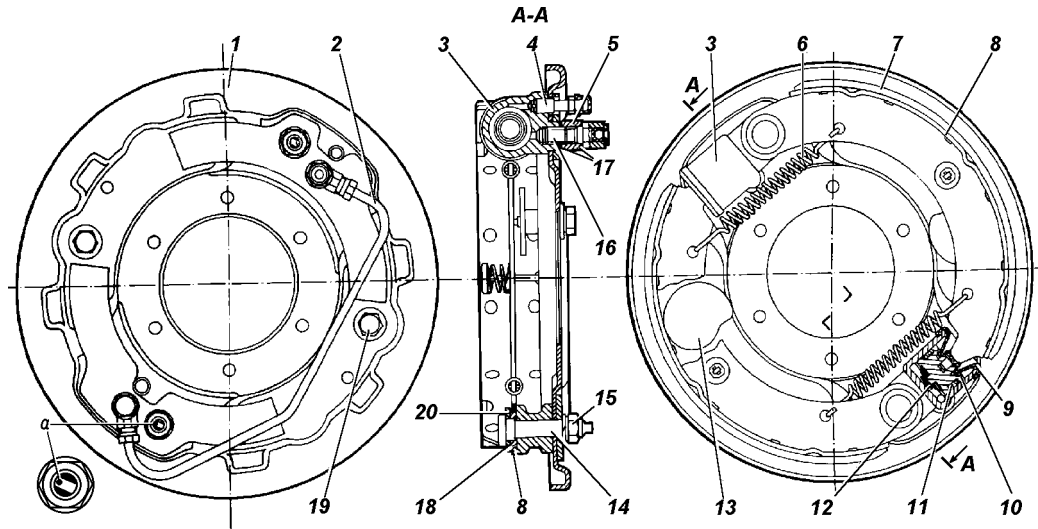

Fig. 61. Front wheel brake:

1 -brake backing plate; 2 -bridge pipe; 3 -wheel cylinder; 4 -bleeder valve; 5 -coupling; 6 -shoe return spring; 7 -brake shoe lining; 8 -brake shoe; 9 -boot; 10 -piston; 11 -sealing rings; 12 -piston spring; 13 -adjusting eccentric; 14 -shoe anchor pin; 15 -nut; 16 -coupling bolt; 17 -gaskets; 18 -support bushing; 19 -adjusting eccentric bolt; 20 -washer

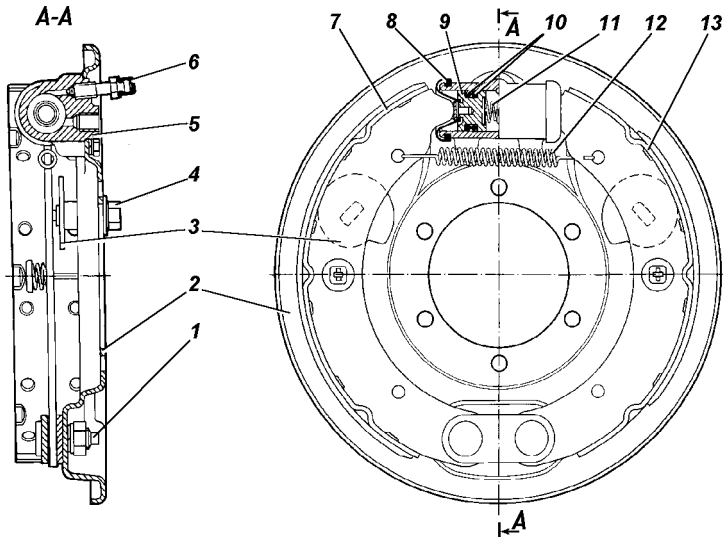

Fig. 62. Rear wheel brake:

1 -anchor pin; 2 -brake backing plate; 3 -adjusting eccentric; 4 -eccentric bolt head; 5 -wheel cylinder; 6 -bleeder valve; 7,13 -brake front shoes; 8 -boot; 9 -piston; 10 -sealing rings; 11 -piston spring; 12 -return spring

Fill the brake hydraulic system in the following sequence:

1. Check all the connections of the brake hydraulic system for leaks and the flexible hoses for proper condition.

2. Remove the radiator shell and unscrew the cap of the brake master cylinder reservoir. Fill up the reservoir with brake fluid.

3. Remove the cap from the by-pass valve of the brake master cylinder or from the pressure regulator and put the end of a rubber hose, about 400 mm long on the by-pass valve.

Dip the other end of the hose in a glass vessel of at least 0.5l capacity half filled with brake fluid (Fig. 63).

4. Screw out the by-pass valve through 1/2 - 3/4 of a turn, then press the brake pedal several times. Depress the pedal quickly and release it slowly.

Under pressure of the brake master cylinder piston, brake fluid fills the hydraulic system and forces out air. Perform the bleeding procedure until air bubbles cease to escape from the hose dipped in the vessel with brake fluid. In the process of bleeding, add brake fluid into the reservoirs of the brake master

cylinder seeing to it that they are never empty in order to prevent penetration of air into the system again.

During the whole operation, keep the free end of the hose dipped in fluid. If neither fluid nor air escape from the hose, the hose is clogged or the valve is closed.

5. With the brake pedal pressed down, tightly screw in the by-pass valve of the wheel brake cylinder, remove the hose and put the cap on the valve.

6. Bleed the remaining brake cylinders in the following sequence: first the rear r.h. brake, rear l.h. brake, then the front r.h. brake, front l.h. brake. On the brakes of the front wheels, first bleed the lower cylinder, then the upper one.

7. After all the brakes have been bled, add brake fluid into the brake master cylinder reservoirs. Screw on the caps of the reservoirs.

8. Switch off the brake warning device for which purpose, do as follows:

- screw out the by-pass valve of the r.h or l.h. wheel brake cylinder of the rear brakes;
- smoothly press the brake pedal until the warning lamp on the instrument panel goes out; if the warning lamp flashes, this means that the pistons of the warning device are passed over the neutral position and it is necessary to repeat the operation by unscrewing the by-pass valve of the front wheel.
- screw in the by-pass valve with the brake pedal depressed.

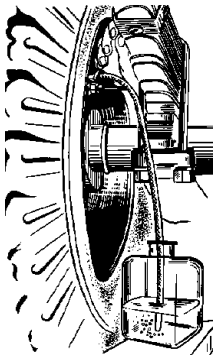

Fig. 63. Bleeding brake system

Check the brakes with the automobile in motion. If the service brake, their control linkage and their hydraulic system have been adjusted and bled correctly, the full application of the brakes should take place within $1/2 - 2/3$ of the pedal travel.

Do not add into the brake master cylinder the brake fluid collected in the glass vessel during bleeding.

Do not depress the brake pedal with the brake drum removed because due to pressure in the hydraulic system, the pistons will be forced out of the wheel brake cylinders and the fluid will flow outside.

Change brake fluid once every two

years for proper functioning of the brakes. When changing fluid, fill up the system until fresh fluid will escape from the hose.

Maintenance of the Parking Brake

Maintenance of the parking brake comes to periodic checking the parking brake mechanism and its control linkage for proper condition and for reliable fastening, cleaning of dirt, adjusting, lubricating the expander and adjuster and eliminating defects, if required.

Periodically disassemble the expander, clean it of dirt and pack with fresh grease, making sure grease does not get on the pack with fresh grease, making sure grease does not get on the drum and friction linings. When disassembling the parking brake mechanism, clean the brake shoes of dust and dirt and also check the friction linings for proper condition. Replace the shoes or linings, if the rivets are flush-mounted on a depth less than 0.5 mm.

Complete braking of the automobile should be insured when the pawl of the parking brake lever is in the third or fourth notch of the sector (3-4 clicks).

Do not allowed to check the parking brake for proper condition when starting away from rest or with automobile in motion. Check the parking brake only on a downhill.

Increased travel of the parking brake lever in the service period may be caused either by large clearance between the brake shoes and drum (in which case, adjust this clearance) or by an excessive free play in the control linkage (in which case, adjust the length of the control rod).

To adjust the brake shoe-to-drum clearance, turn in the screw 10 (Fig. 64) on the brake anchor plate, and then turn out the screw against the stop through 4-6 clicks ($1/3$ - $1/2$ of a turn) until the drum is free to rotate.

Adjust the length of the parking brake cable in the following sequence:

1. Shift the lever to the extreme forward position.
2. Screw off locknut of adjusting fork 1, uncotter and take out the pin securing fork to control lever.
3. Rotate the adjusting fork to take up all plays in the control linkage.
4. Give the adjusting fork 1.5-2 turns out, align the holes in the fork and lever, insert and cotter the pin and tighten the locknut.

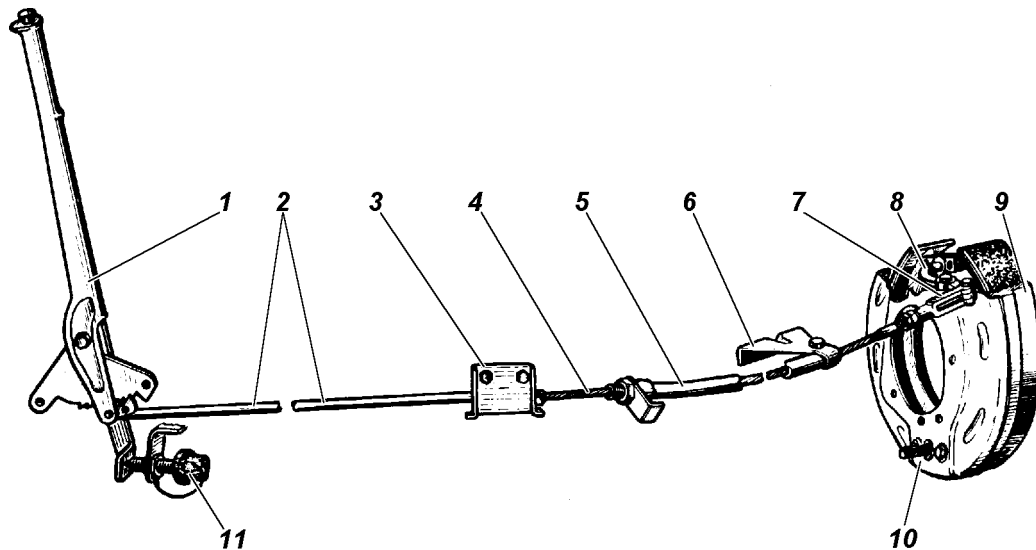

Fig. 64. Parking brake linkage:

1 -linkage lever; 2 -rod; 3 -bracket; 4 -cable; 5 -protective tube; 6 -protective tube bracket; 7 -cable fork; 8 -lever; 9 -parking brake drum; 10 -adjusting screw; 11 -warning lamp switch

ELECTRICAL EQUIPMENT

See wiring diagrams of automobiles in Appendix 4.

Maintenance of the Alternator

The automobiles could be provided with the alternator with a built-in rectifier operating in conjunction with a voltage regulator. The automobiles could be equipped with alternators of two types:

- 665.3701-01 or 161.3771 - with brush assembly;
- Г700А.30 or 957.3701-10 - without brushes.

Check the alternator function in accordance with ammeter reading. When the ignition and the engine are off, the ammeter shows the voltage across the battery terminal, and after the engine starting - the voltage across the alternator terminal.

The voltage across the alternator terminal should be 13.5 - 14.8 V.

If the voltage is increased, check the alternator or the voltage regulator and eliminate the defect.

The built-in integral voltage regulators are not repaired. In case of breakage of the regulator replace it for the regulator of the same type.

Periodically check the brush assembly and the contact part of the integrated voltage regulator for proper condition. To do this, remove the alternator 665-3701 from the automobile, and remove the brush assembly on the alternator 161.3771. Replace worn-out brushes.

Maintenance of the Storage Battery

The storage battery is installed in the cab on the left, behind the wheel mud guard.

The storage battery is connected parallel to the alternator. If in the service period of the automobile, the storage battery is gradually discharging or is excessively charging by the alternator, and the electrolyte begins to gas, check the alternator for proper condition.

Keep the storage battery clean and in charged state, protect its leads and terminals from oxides as indicated in Lubrication Table.

Periodically clean vent holes in plugs, check the electrolyte level and, if required, add distilled water.

Check the electrolyte level in each battery cell on a cold battery and if necessary, add distilled water up to the lower end of the filler hole tube.

Before operation, depending on the climatic condition under which the automobile is to be employed, correct the electrolyte specific gravity.

New automobiles delivered from the manufacturing plant are furnished with the storage batteries filled with electrolyte of the same specific gravity equal to 1.27 g/cm³.

The battery discharged by more than 25% in winter and more than 50% in summer is to be charged.

Specific gravity of electrolyte reduced to 25 °C, g/cm³

Fully charged battery	Battery discharged by	
	25%	50%
1.30	1.26	1.22
1.28	1.24	1.20
1.27	1.23	1.19
1.26	1.22	1.18
1.23	1.19	1.15

Do not allow discharging the battery under a heavy load current for a prolonged period of time (when starting cold engine in winter) because it could provoke curling of electrodes, falling-out of active material and reduces service life of the storage battery.

Carefully prepare the engine for starting and switch on the starter for 5 s maximum.

Cut off the battery by means of the ground switch if the automobile is to be removed from operation for a prolonged period of time.

Maintenance of the Starter

Before removing the starter for servicing open the battery switch.

Periodically clean the starter of dirt, visually check the starter for proper attachment to the clutch housing.

Check the condition of terminals, working surfaces of contacts, remove caking with a fine cut file, then wipe them with

waste and blow out. Check the starter drive, its pinion, lever and spring.

Clean of dirt frictioning parts, wash out and wipe them dry, if required, lubricate with grease "Литол-24".

Check axial play of the rotor shaft which should be not more than 1.0 mm. If required, tighten up bolts of the starter frame.

The starter drive is to be freely shifted along the shaft splines and returned to its initial position by means of the return spring. The rotor should not be rotated when rotating the drive pinion in the direction of working rotation. Check the rotor by hand for easy rotating in bearings when brushes are risen up. Replace the brushes if their length is less than 6 mm.

Warnings: 1. The overrunning clutch of the starter could be failed if the starter is keeping on after starting the engine.

2. Do not wash the starter covers and drive with gasoline or kerosene to avoid washing out grease out of bronze-graphite oilless sliding bearings.

Lighting System, Light Flashers and Horn

Maintenance of the headlamps amounts to their aiming and replacing defective lamps, cleaning of dust from the headlamp body and lens.

In spite of the good sealing, dust may penetrate into the sealed beam unit. For removal of dust, wash the sealed beam unit with clean water and a cotton wad, and dry at a room temperature.

For replacing the bulb in the headlamp, turn out screw 1 (Fig. 65) securing garnish molding 2 and remove it. Loosen three screws 5 and take out inner molding 4 together with the sealed beam unit 3.

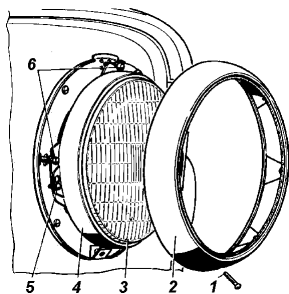

Fig. 65. Headlamp:
1,5 -screws; 2 -garnish molding;
3 -sealed beam unit; 4 -inner
molding; 6 -adjusting screws

Perform aiming of the headlamps in the following sequence:

1. Place ready for road automobile with a driver's seat load of 75 kg. on a level ground. Erect the aiming screen in front of the automobile at a distance of 5 m. Remove the rims.

2. Switch on the headlamp and by operating the foot switch be sure that the lower and upper beams are lighting up simultaneously.

3. Turn on the lower beam and cover one headlamp. Adjust the beam by turning the screws 6 (Fig. 65) until the area of the concentrated light corresponds with the marks on the aiming screen or the wall as indicated in Fig. 66. The adjusting screws of the headlamp 62.3711-09 are located symmetrical about the headlamp center in the horizontal plane.

4. Adjust the second headlamp in the same manner ensuring that the upper edges of concentrated lights are at the same height.

5. Fasten the rims.

Adjust the fog lamps that the area of concentrated light on the aiming screen or the wall is located as indicated in Fig. 67. For replacing the fog lamp bulb, remove the cover of the bulb holder by turning it counterclockwise and take out the bulb.

Front headlamps, rear lamps, backing lamp, side turn indicator repeaters, rear fog lamp. For replacing the lamps, undo screws attaching the lens and remove it.

License plate lamp. For replacing the lamp, undo the screw attaching the cover, remove the cover and the lens.

Maintenance of the horn amounts to periodic checking it for proper fastening, tightening the wire clamps, cleaning of dirt and dust, and also to checking the sound intensity and adjusting, if required.

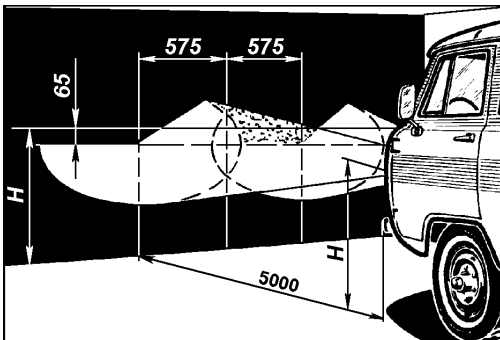

Fig. 66. Aiming screen for headlamp adjustment: H - distance from center of headlamps to ground level

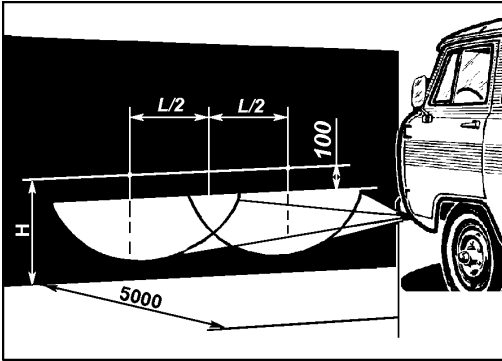

Fig. 67. Aiming screen for fog headlamp adjustment:

H - distance from center of headlamps to ground level

L - distance between centers of fog headlamps

Adjust the horn in a workshop.

Turn indicators. The turn indicators are switched on manually by means of the switch and switched off automatically.

Maintenance of the turn indicators comes to insuring a clearance of 2-2.5 mm between the rubber roller of the switch and the hub of the steering wheel with the switch lever set in the neutral position. Adjust the clearance by moving the switch along the bracket. Shift the switch lever from one into another position smoothly without jerks and blows. Take care to prevent getting of lubricant and water on the switch rubber roller and keep the roller clean.

Overload Breakers

The circuits of the instruments, horn, heater motors and windshield motor are protected by fuses. The fuse unit (Fig. 68) provided with three fuse 10 A each is located under the instrument panel on the l.h. pillar of the door aperture.

The fuse 1 protects the fog lamp circuit (refer to Fig. 13, 14).

Before replacing the worn-out filament of the fuse link or before switching on the thermal pushbutton cut-out, determine the cause of overloading and eliminate defects.

Instrumentation and Warning Flashers

Instrumentation and warning flashers are intended to keep watch on the condition and function of some mechanisms and units in the automobile. They consists of: speedometer, voltme-

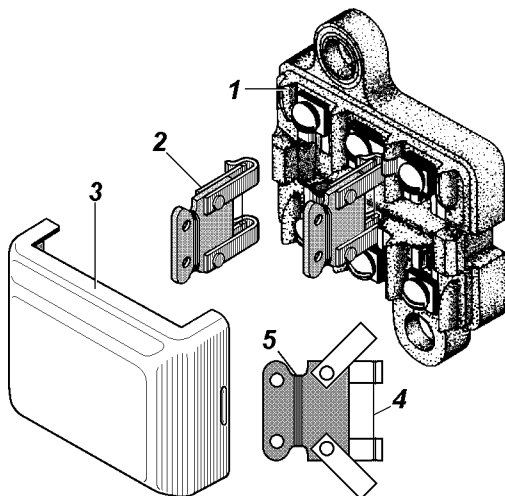

Fig. 68. Fuse unit:
 1 -fuse unit body; 2 -fuse link; 3 -body cover; 4 - fuse link filament; 5 - reserve filament

ter, oil pressure gauge, engine coolant gauge and fuel level gauge. The gauges operate in conjunction with transmitters.

The automobile is provided with the automobile emergency condition warning flashers (all the turn indicators flush simultaneously).

Maintenance of the devices comes to periodic checking the devices for proper attachment, terminal connections for proper condition, cleaning them of dust and dirt.

Before removing the electric transmitters, insulate the end of a lead in order to prevent a short circuit. For removing the transmitters, use a box wrench or hexagon wrench to avoid damage of the transmitter body.

Do not allow a drop of the coolant level in the radiator, as it may cause failure of the temperature transmitter.

Check the coolant temperature gauge for proper reading once a year. To do this, immerse the transmitter into hot water and measure its temperature by means of the test thermometer.

Check the oil pressure gauge and oil emergency pressure warning lamp transmitter for proper reading by means of the test pressure gauge once a year.

Check the flexible shaft for proper installation. The flexible shaft should be installed in that way that the radius of bending would be not less than 150 mm.

SPECIAL TOOLS AND APPLIANCES

New automobiles delivered from the manufacturing plant are provided with a set of tools and appliances. Use this set for maintenance and simple repair of the automobile en route. For convenience of storage, there are two tool bags in the automobile: a big and a small one.

Use a **plunger grease gun** (Fig. 69) for lubricating the automobile assemblies provided with nipples.

For lubricating, pull the handle 12 until the stud 13 touches the piston 7; by rotating the handle insert the stud through slot of the piston and by rotating the handle lock the stud in the piston, fit the head 1 over a nipple. When rocking the lever 8, press the handle 12.

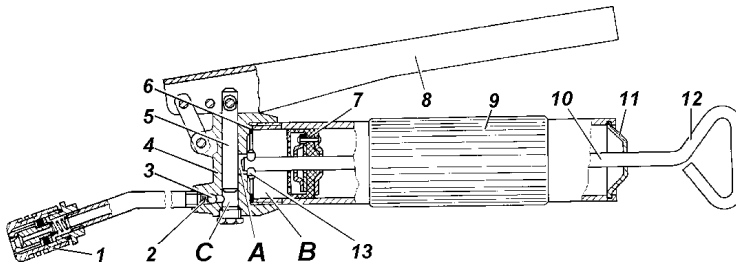

Fig. 69. Grease plunger gun:

1 -head; 2 -spring; 3 -ball valve; 4 -body; 5 -plunger; 6 -gasket; 7 -piston; 8 -lever; 9 - gun cylinder; 10 -rod; 11 - cover; 12 -handle; 13 -stud

Fill the gun with grease in the following sequence:

1. Screw the cylinder 9 out of the body 4.
2. Pull the piston 7 inside of the cylinder through 1/5 of strokes by means of the handle 12.
3. Using a wood spatel, fill the gun cylinder with grease. Then press the piston against the stop and fill the whole cylinder with grease. Make sure, there are no air bubbles in the cylinder.

The gun fails to be operated if air would find its way into the chamber B.

For deaerating, unscrew the bolt of the cylinder C, press the gun handle until grease is emerged and tighten the bolt.

The capacity of the chamber B is 340 cm³ of grease.

The jack (Fig. 70) is designed to jack up the automobile wheels for maintenance. The jack load-lifting capacity is 2 t. The maximum height of lifting is 240 mm.

For jacking up the wheel, proceed as follows:

1. Install the jack on a level ground under the axle shaft sleeve.

2. Turn out the jack internal screw 3 as high as the clearance between the axle shaft sleeve and the ground permits.

3. Throw over the jack latch 5 to the l.h. side relative to the jack handle 6 so that the latch projection enters the tooth space of the ratchet wheel 7.

4. By stroking the tyre iron inserted on the hole of the jack handle, lift the automobile wheel to a required height.

For jacking down the wheel, throw over the jack latch to the r.h. side and by stroking the tyre iron, jack down the wheel. After work is over, turn the internal 3 and external 2 screws in the jack body as far as they will go.

Maintenance of the jack amounts to periodically cleaning it of dirt and lubricating the external and internal screws.

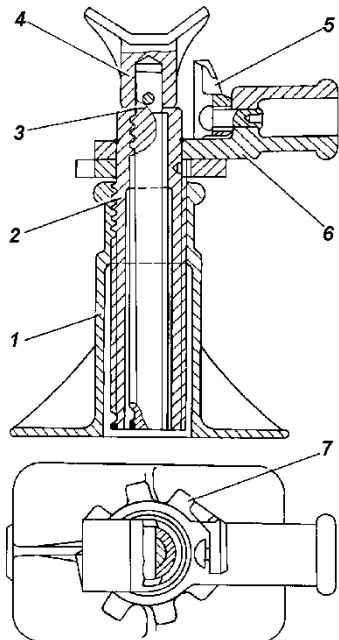

Fig. 70. Jack:

- 1 -body; 2 -external screw;
- 3 -internal screw; 4 -head;
- 5 -pawl; 6 -handle; 7 -ratchet

BODY(CAB)

The body of the automobile YA3-3962 is provided with the partition complete with sliding glasses. The ambulance compartment is equipped with hinged seats, brackets and straps for attachment of a stretcher, grab handles in door apertures and on the roof, and curtains for the windows of the body side panels, doors and partition.

The passenger/cargo compartment of the automobiles YA3-39625 is equipped with three folding double seats, one unfolding single seat and a demountable folding table. Depending on the complete equipment, the automobiles could be equipped with a folding single seat instead of an unfolding single seat and demountable folding table.

The passenger compartment of the automobile YA3-2206 is equipped with three single and two triple seats of which the rear one is a triple folding seat*.

The passenger compartment of the automobile YA3-3909 is equipped with a demountable folding table, two single and one triple seats. The passenger compartment is divided from the cargo compartment by a partition with the sliding glasses.

The passenger compartment of the automobile YA3-39094 is equipped with a triple cushioned seat.

The cab of the automobile YA3-39095 is equipped with a hinged berth for cargo (up to 110 kg) or special equipment and a cargo compartment under the berth.

The body and cab doors are sealed with rubber foam seals.

Avoid spilling fuel and oils on the door rubber seals.

Additionaly, the automobiles could be equipped with:

- guard for the radiator shell and headlamps;
- sunroof of the cab;
- seats (for driver and passenger) with adjustment: longitudinal, backrest inclination and heigh;
- locking plugs of fuel tanks;
- upholstery of doors and cab rear wall;
- improved sound insulation of the hood;
- container installed on the hood.

* Depending upon the complete equipment , could be not installed.

Body (Cab) Ventilation

The cab is ventilated through the air vent in the middle part of the cowl and the heater box shutters, and also through the swivelling quarter-lights and drop windows of the cab doors. To make the cab ventilation more effective, make use of the heater fan, but for that shut off the cock on the cylinder head.

Fresh air is admitted into the sanitary and passenger compartments through the swivelling quarter-lights of the side glasses, and also through the heater box when the shutter is completely open and the radiator is shut in. To make the ventilation more effective, make use of the heater fan.

Ventilation of the cargo compartment is effected through the shutters in the front and rear parts of the body side panels.

Body (Cab) Heating

The cab heating and defrosting of the windshield are effected through the heater-radiator (Fig. 71) connected into the engine cooling system in parallel with the main radiator.

The warm air is admitted either for demisting the windshield completely or for heating the cab and demisting the windshield depending upon the positions of the shutters 4 (Fig 71) and the lid 3. Intensity of air flow could be controlled by the air vent lid of the cowl.

Effective operation of the heater is insured when a temperature of coolant in the engine cooling system is not less than 80 °C. Check the coolant temperature in the engine cooling system, adjust it by shutting the radiator shutter folds of the cooling system.

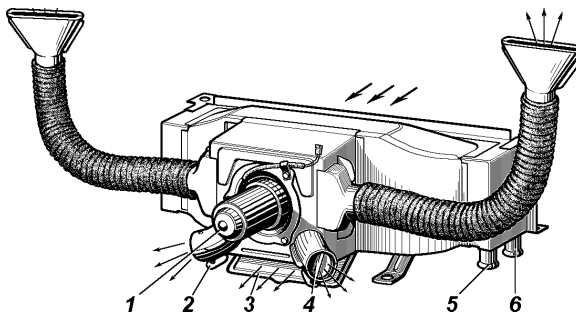

Fig. 71. Cab heating and windshield demisting diagram: 1 -fan motor; 2 -shutter handle; 3 -lid; 4 -shutter; 5, 6 -radiator manifolds

When starting the cold engine in the winter, shut off the cock on the cylinder head. Open the cock only when the engine is warmed up. The sanitary and passenger compartments are heated by an independent heater (Fig. 72), which is operated similar to the cab heater. The fresh air is sucked in through the heater radiator fan and passes into the rear compartment. The heater selector switch is located in the driver's cab on the r.h. side of the partition.

Sanitary Equipment of the Automobile YA3-3962

The following sanitary equipment could be placed in the sanitary compartment of the automobile (Fig. 73):

Unified stretcher.....	4
Sanitary bag	1
Bag with oxygen inhaler КИ-3М	1
Bag with feeding-cup.....	1
Reservoir for drinking water	1
Urine receiver	1
Bed-pan	1
Wire splints	2
Splints	2

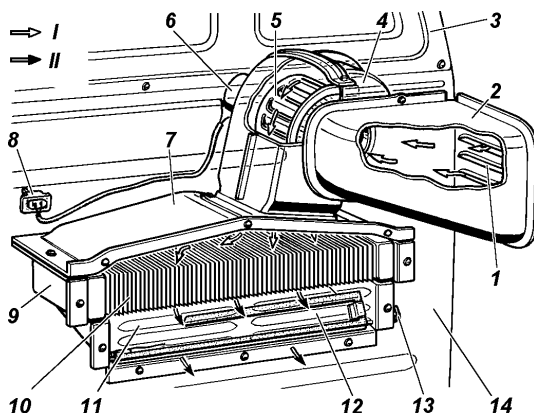

Fig. 72. Heating of sanitary and passenger compartments:

I -cold air; II -warm air

1 -louvers in body side panel; 2 -air duct housing; 3 -upper portion of partition (installed only in sanitary compartment); 4 -fan assembly; 5 -fan impeller; 6 - electric motor; 7 -heater shell; 8 -electric motor switch; 9 -radiator shell; 10 - radiator; 11 -louvers in lower portion of partition; 12 -shutter; 13 -shutter control handle; 14 -lower portion of partition

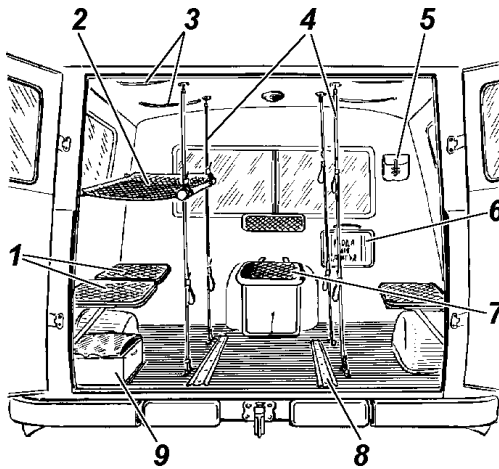

Fig. 73. Location of sanitary equipment:

- 1 -hinged double seats;
- 2 -stretcher; 3 -rails; 4 - suspension straps; 5 -bag;
- 6 -reservoir for drinking water; 7 -hinged single seat; 8 -stretcher guide;
- 9 -box

For installing and fastening an unified stretcher in the sanitary compartment each of the side panels is provided with four hinged brackets, the ceiling is provided with holders and the body floor is provided with clips for attachment of suspension straps.

For carrying walking patients three double seats are installed in the ambulance body: two on the l.h. side of the body and one on the r.h. side; the body ceiling is provided with hand straps located opposite to each seat.

An accompanying person takes up the hinged seat secured to the partition. The hooks for the sanitary bag with the oxygen inhaler and feeding-cup are also secured to this partition.

The box provided with three pigeon-holes for bed pan, urine receiver and suspension straps is located on the body floor on the left in the rear part of the sanitary compartment.

The splints are secured with two straps on the body side panel in the r.h. corner.

The guides on the body floor make easy moving the stretcher along the body.

Carrying Patients

The automobile YA3-3962 and its equipment permit to carry from 6 to 8 persons (driver not included) at the following accommodation:

FIRST ACCOMMODATION:

- On hinged seat 1 person
- In driver's cab 1 person
- On stretchers 4 persons

SECOND ACCOMMODATION

- On stretchers on the left 2 persons
- On hinged seats 3 persons
- In driver's cab 1 person

THIRD ACCOMMODATION

- On stretchers on the right 2 persons
- On hinged seats 5 persons
- In driver's cab 1 person

FOURTH ACCOMMODATION(without stretchers)

- On hinged seats 7 persons
- In driver's cab 1 person

Before run, make the automobile ready for receiving patients.

For that, check the stretcher strap knots for reliability, check the brackets for proper securing to the body panels, for proper functioning, check the suspension strap clips for proper securing.

After checking the equipment and sanitary belongings, fit the suspension straps (Fig. 74).

When carrying patients accommodated on seats, remove all the stretchers and hinge out the side seats. Put a pair of the stretchers together, tie up with straps and place along the sanitary compartment under the hinged-out seats.

Remove the suspension straps, roll them up and place into the box.

Then, check the hinged seats, flexible rails and footsteps of the body rear end door for reliability.

Fastening Stretcher

When installing the stretchers with patients, fasten at first the upper stretcher, then fasten the lower one.

Fasten the handle of one stretcher beam to the hinged brackets, fasten the other handle in loops of hanging down straps, then close the bracket and tighten the strap loops by means of the pressing frame (Fig. 75). The rear straps are provided with labels.

After installing the lower stretcher, attach the hanging down strap ends to the special clips on the body floor.



Fig. 74. Fitting suspension strap in place

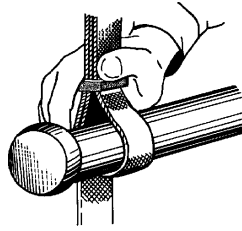

Fig. 75. Fastening stretcher handle in strap

When carrying patients, be carefull, start away from rest smoothly and avoid abrupt braking.

Windshield Wiper and Windshield Washer

For convenience, when washing the windshield, the blade-and-lever assemblies could be swung out of the way.

For increasing the service life of the windshield wiper and its blades, the operation of the blades on dry glass is not recommended.

In the service period, check the windshield, rear window and headlamp wipers for proper functioning, check them for reliable attaching, periodically clean the glasses and rubber tapes of blades of dirt and grease.

During the seasonal maintenance, switch on the wipers for 15-20 min, in this case the blade-and-lever assemblies of the windshield should be swung out of the way, and the blade-and-lever assemblies of the rear window should be removed.

After 18-24 months of run and also, if required, replace blades and rubber tapes.

Washer (Fig. 76). The electric washer is intended for high-speed cleaning the windshield.

Fill up the washer reservoir with clean water (in summer) or with special antifreezing fluid (in winter).

Adjust the direction of fluid jet (except for headlamp washer jets) by changing the position of the jet balls by means of a needle inserted through the channel of the balls. When clogging the jet, uncouple the pipe and blow out the jet.

Keep watch on the level of fluid in the reservoir not allowing

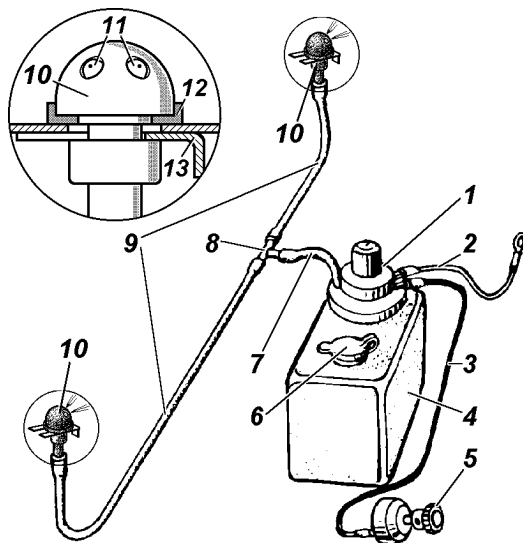

Fig. 76. Electric washer:

1 -pump body complete with electric motor; 2 -ground wire; 3 -wire "+"; 4 - reservoir; 5 -combined switch; 6 -cover; 7, 9 -hoses; 8 -tee-piece; 10 -jet; 11 - jet ball; 12 -gasket; 13 -clamp

it to drop below a value of 20 mm above the reservoir bottom in order to avoid failure of the washer pump.

Never keep the washer switched on in excess of 10 s.

Maintenance of the Body

To take care of external appearance of the automobile, maintain regularly the varnish coating of the body. Do not wipe dust and dirt with a dry cloth. Wash the body with water jet of low head using soft rags. Upon washing, wipe the body surfaces dry. Do not use soda or alkaline solutions because the varnish coating could be become dull. Avoid exposing the automobile to sunlight for a long time. Never spill acids, solutions, soda, brake fluids, fuel and antifreezing agents on the painted surface of the body and rubber parts.

To take care of the body coatings, use prophylactic polishing liquids.

Straighten minor surface irregularities, if required, clean of dirt, grind and paint.

If damage of the body (cab) is considerable, prime, dry and paint the surface.

During service of the automobile, periodically treat the body surfaces, especially enclosed spaces, with corrosion-preventive compounds, as "Mobil", "Tectil" etc.

If required, recovery the body floor coated with bituminous cement by spreading it by means of a special spray or brush.

If required, clean the seat upholstery, for that make use of a neutral soap with water (water-and-soap solution), then wipe dry with a soft cloth. Never make use of fuel for cleaning the upholstery of leather substitute.

Remove the heater radiator and remove scale and sediment, if using water as a coolant, before winter and summer seasons.

Scale and sediment are removed by flushing them with a fast jet of clean water. The direction of the flushing water flow should be reverse to the direction of the hot water flow. Also, carry out external washing of the radiator.

Lubricate according to Lubrication Table: locks, hinges and catches of doors; door check joints; joints of windshield wiper blade control linkage, bearings of windshield wiper and body (cab) heater motors.

LUBRICATION OF AUTOMOBILE

Service life and trouble-free operation of the automobile depend to a great extent on timely and correct lubrication.

The lubricating materials and special fluids are specified in this Instruction Manual. The points on the chassis and engine subject to lubrication are indicated in Lubrication Table.

If there are no special instructions in the column "Description", the indicated oil or grease sorts are used in all seasons.

If several grease marks with the same periodicity of changing are indicated in the column, all the marks are interchangeable. If the grease mark is provided with the note "substitute", and the other periodicity of changing is indicated, use preferably the base grease mark.

In the process of lubrication, adhere to the following rules:

1. Change oil from the engine and transmission when the units are hot.
 2. Remove dirt from the grease fittings and plugs.
 3. Upon lubrication, remove the squeezed out or leaked lubricant from all parts.
 4. Before filling the transmission case, transfer box, the housings of the front and rear axles with fresh oil, wash them, if the waste oil drained from the mentioned units is contaminated or metal particles are detected in it.
 5. Mixing the grease "Литол - 24" with the substituting grease "Лита" is allowed in any proportions. When using other substitutes wash the unit with kerosene.
 6. Mixing the brake fluids "Роса", "Роса-3", "Томь", "Роса Дот-4" is allowed in any proportions.
- If metal particles are detected in oil, open the unit, check it and replace the worn parts.

PRESERVATION

If the automobile is to be removed from operation for a prolonged period of time, it should be subjected to preservation, for which purpose, do the following:

1. Carry out the scheduled maintenance.
2. Wash the automobile and wipe it dry. Touch up the paintwork wherever damaged.
3. To protect the engine cylinders against corrosion pour 30-50 g of engine oil into the cylinders through the spark plug holes. To insure uniform spreading of oil throughout the entire surface of cylinders, crank the engine through 15 revolutions by the starting handle.
4. Clean all wires from dirt and wipe dry.
5. Using the preservative lubricant ПБК (for lack of it - with petrolatum), coat all unpainted external metal surfaces of the automobile and all unpainted parts of hinged joints (hinges and locks of doors, control rods of the carburettor, parking brake, towing gear, and other parts and also ignition coils).
6. Lubricate the springs with a graphite lubricant.
7. Check, clean the tools, accessories and spare part set and wrap them with oiled paper or with cloth.

8. Seal the external cab glasses with light-tight paper (cloth) or shut with shields.

9. Remove the wheels for automobile, clean the wheel disks of dirt and touch up the areas with damaged paint. Clean, wash and wipe dry the tyres, and bring the tyre inflation pressure to normal.

10. If required, flush out the fuel tanks and fill them with fuel.

11. Prepare the battery for storage as is specified in the maintenance manual of lead-acid batteries.

12. Seal the slits of the air cleaner and the muffler exhaust pipe with oiled paper.

13. Loosen the tension of the fan driving belt.

14. Drain the coolant from the engine cooling system and the fluid from the windshield washer reservoir.

15. Seal the transfer box and housings of the front and rear axles for each purpose, wrap the safety valves with the insulating tape.

16. Clue the clearances between the brake drums and backing plates with oiled paper.

17. Protect the tyres and other rubber parts from action of direct sunlight.

18. Put under the axles the metal or wooden props, that the wheels would be raised above the surface.

Unload the springs; for that put the wooden struts between the frame and axles. The preserved automobile should be located in a clean, ventilated room with relative humidity 40-70% and temperature not less + 5°C.

Do not keep chemically aggressive substances such as acids, alkalis and other in one location with the automobile.

Maintenance of Automobile Placed in Storage

Once in two months, carry out the following operations:

1. Carefully inspect the automobile from the outside.

2. Unscrew the spark plugs and shift in the first gear of the gearbox and the low range of the transfer box, then turn the crankshaft with the starting lever through 15 of a turn. Once a year before turning the crankshaft lubricate the engine cylinders with 30-50 drops of engine oil.

3. Clean and paint corroded areas, if any are detected.
4. Rotate the steering wheel from lock-to-lock position for 2-3 times.
5. Check the service and parking brakes, clutch, choke and throttle valves, manual and foot-operated linkages of the throttle valve, headlamp switches for proper functioning.
6. Check the level of working fluid in the reservoirs of the brake master cylinder and the hydraulic clutch master cylinder, and, if required, top up to normal.
7. Inspect the ignition distributor, and if required, lubricate its metal parts.
8. Check the tools and accessories, if required, wipe and lubricate them.
9. Check the condition of tyres and other rubber parts.
10. Eliminate the troubles detected during inspection.

Depreservation

1. Remove the preservative lubricant from the parts for which purpose, wash them with kerosene or clear gasoline. Remove the lubricant from areas which may come in contact with rubber parts or painted surfaces.
2. Carry out daily maintenance.
3. Check the level of oil in the engine crankcase and drain an excess amount of oil.
4. Before engine starting lubricate each cylinder with 30-50 drops of engine oil and turn the crankshaft with the starting lever through 10-15 of a turn.

LUBRICATING MATERIALS AND SPECIAL FLUIDS

Description of fluid or grease	SAE equivalents
Motor Oils	
M6 ₃ /12Г ₁	SAE 15W-40
M-5 ₃ /10Г ₁	SAE 10W-30
M-6 ₃ /10B	SAE 10W-40
Transmission Oils	
ТСП-15K	SAE 90
ТСП-10	SAE 75W
Lubricant Greases	
Grease Литол-24	Lithium grease to NLGJ №3
Graphite powder	Barbatia Grease 2
Fluids	
Shock absorber fluid АЖ-12Т, Spindle oil АУ	Shock absorber oil, Shell Donax A
Brake fluid "Томь", "Роса" "Роса-3", "Роса Дот-4"	SAE 1703F, DOT-4
Cooling fluid ТОСОЛ-А40М	Shell safe

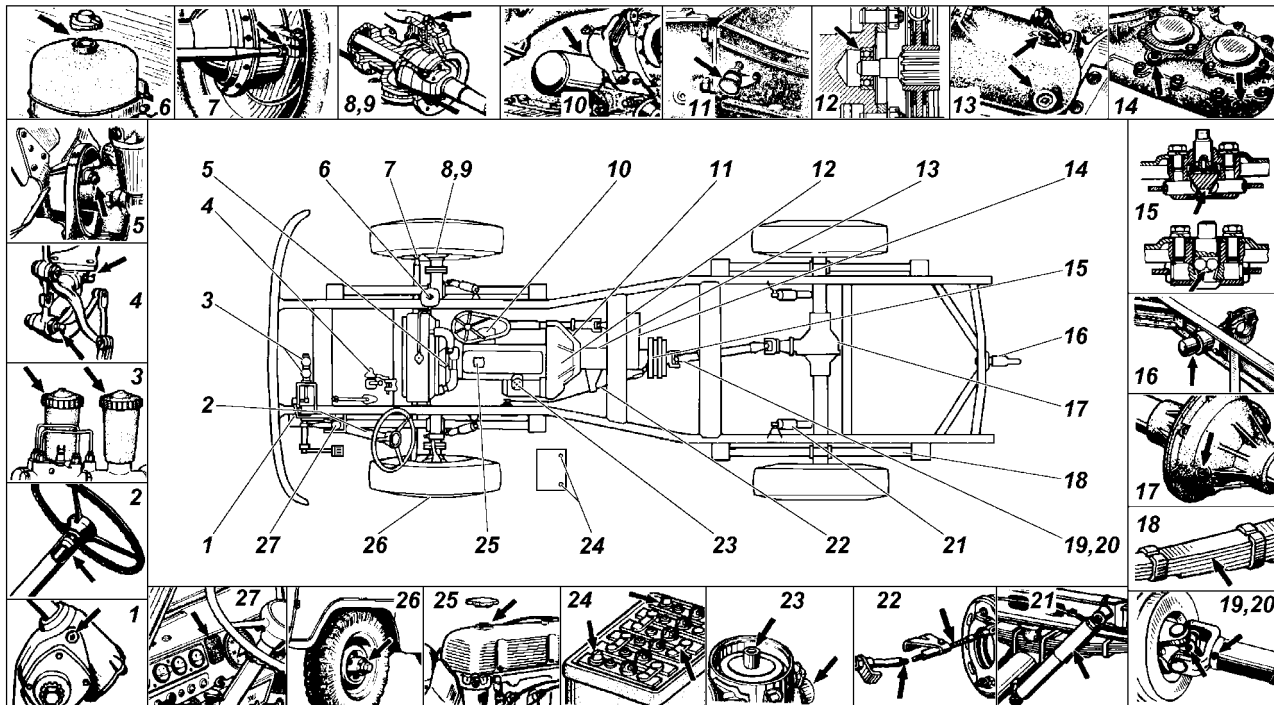

Fig. 77. Lubrication and tank chart of automobile

LUBRICATION TABLE

Ref. Nos.in Fig.77	Description of units	Number of lubric. points	Lubricant or fluid	Lubrication intervals	Lubrication instructions
1	2	3	4	5	6
25.	Engine crankcase	1	<p style="text-align: center;">Motor Oils</p> All-purpose M-6з/12Г ₁ or Сам Ойл 4111, Сам Ойл 4112, Сам Ойл 4113 M-6з/10B, M-4з/6B ₁ , M-5з/10Г ₁	The first - after 1000 km of run, the subsequent - after 16000 km of run or at seasonal maintenance	If required, top up
10.	Engine oil filter	1		Every 8000 km of run	Replace filter after running-in
23.	Distributor rotor bush	1	Motor oil	Every 32000 km of run	Lubricate with 4 or 5 drops (before lubricating, remove runner and filter)

1	2	3	4	5	6
			Transmission Oils		
13.	Gearbox case	1	ТСп-15К or ТАП - 15В, ТАД-17И, ТСп-10 - only in cold season (from 1.10 to 1.04)	ТАП-15В - every 32000 km of run, ТСп-15К and ТАД-17И - every 48000 km	Add as required
14.	Transfer box case	1			
17.	Front and rear axle final drive housings	2			
1.	Steering gear housing	1		When repairing	Add as required
			Lubricant Greases		
20.	Front and rear propeller shaft splines	2	Grease "Литол-24" Grease "Лита" Grease "Литол-24РК"	Every 8000 km of run	Lubricate through grease fittings (3-5 strokes of gun without forcing grease out)
19.	Front and rear propeller shaft joints	4			
5.	Cooling system pump bearings	1		Every 16000 km of run	Add as required
-	Heater motor bearings	to 2			Lubricate with thin layer

1	2	3	4	5	6
4.	Gearbox control linkage	3	Grease "Литол-24" Grease "Лита" Grease "Литол-24РК"	Every 32000 km of run	Lubricate through grease fittings
7.	Steering rod joints	4			Lubricate through grease fitting until it shows up from under upper seal washers
8.	Steering knuckle joints	2			Wash joints and pack 500 g of grease
9.	Steering knuckle kingpins	2			Lubricate through grease fitting of upper kingpin
11.	Clutch release bearing	1			Pack grease cup to capacity
15.	Parking brake expander and adjuster mechanisms	2			Clean of dirt before lubricating
16.	Towing gear	1			Lubricate through grease fitting. Lubricate latch and pawl axles as required
26.	Front and rear wheel hub bearings	4			Grease layer in bearings should be 10-15 mm thick. Space between rollers should be filled up completely.

1	2	3	4	5	6
12.	Gearbox input shaft front bearing	1	Grease "Литол-24" Grease "Лита" Grease "Литол-24РК"	Add when removing	
22.	Parking brake cable	1		As required	Clean of dirt before lubricating
24.	Storage battery terminals	2			Protect terminals against acid
-	Door hinges				Lubricate through grease fitting
-	Door lock tongues, sockets and latches, hinges of door checks				Lubricate
2.	Steering wheel shaft bearings	2		As required, when squeaking bearing and when disassembling	
-	Door locks		Grease "Литол-24" Apply grease ЦИАТИМ-201 at temperature below 40 °C	As required	Lubricate

1	2	3	4	5	6
18.	Front and rear springs	4	Graphite grease YCCa	Lubricate as required, when creaking	Lubricate rubber surfaces of spring leaves
-	Rubber weatherstrips and door tongues		Graphite powder	Every 16000 km of run	Wipe
3.	Brake master cylinder	2	Fluids		Add as required
27.	Clutch release master cylinder	1	Brake fluid "Роса", "Роса-3", "Томь", "Роса Дот-4"	Once in two years	
21.	Front and rear shock absorbers	4	Shock absorber fluid АЖ-12Т, spindle oil АУ, oil for hydraulic shock absorbers МГП-10	As required and when disassembling	
6.	Engine cooling system with expansion tank	1	Cooling fluids ОЖ-40 "Лена", ОЖ-65 "Лена" or ТОСОЛ-А40М, ТОСОЛ-А65М	Change once in three years or after 60000 km of run	Wash cooling system before oil changing. Check coolant level. The level should be higher 20-30 mm than mark "min" on expansion tank

Note. The first indicated in column 4 grease is the basic grease.

TRANSPORTATION

The automobiles are transported depending on the user location: by water, railway or air transport. The transportation of the automobiles without assistance (on the move) is allowed.

When transporting the automobiles in the hold or on the desk, and also by air transport make them fast in accordance with the ship scheme or air transport scheme. Use appliances, which not damage the parts and paint of the automobile.

Before loading check the driver's kit, accessories and spare parts in accordance with the complete list.

The loading and unloading should be carried out by a crane with special grips in accordance with the scheme in Fig. 78.

On all transports, the automobiles should be located so that the distance between the automobiles (extrem points) on the radiator side would be equal to 50-100 mm, and on the other sides - not less than 100 mm.

When transporting, the parking brake of the automobile should be on, the engine - shut down, the gearbox lever should be in the position of the first gear, the fluid (water) should be

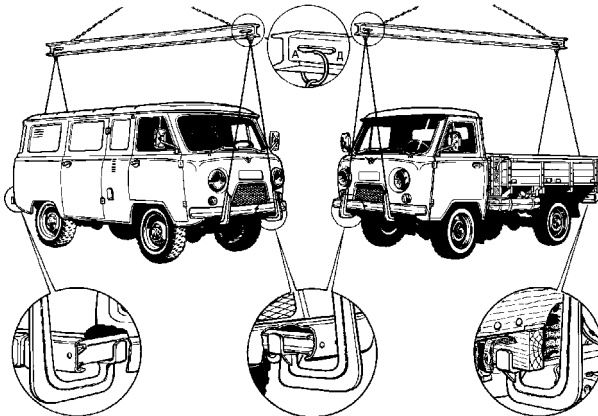

Fig. 78. Scheme of automobile loading (unloading):
A and Д - slots of gripping devices rings for automobile location with diverse weight and in level position

poured out from the cooling system and the sighthoard "Water is poured out" should be hanged, the storage battery should be cut off by means of the ground switch.

To protect the automobile from axial and side shiftings attach it with four tension wires of steel wire (dia. 6 mm) with double thread each, and also with wooden wedges 300x160x80 nailed to the floor under wheelies. Attach the tension wires to the towing hooks on the frame ahead, and to the towing gear-in rear part of the automobile. After attaching seal the automobile.

Before air transporting, the fuel tanks should be filled with fuel not more 75% of its capacity.

The automobile should be get into an airplane with the first gear of the gearbox and with the low range of the transfer box or with the backward motion (depending on the loading or unloading conditions).

LAMPS EMPLOYED ON AUTOMOBILES

Lamps	Type	Power, W
Headlamps: upper and lower beam	12-45x40 AKГ12-60+55-1(H4)	45x40 or 60x55
Swivelling lights*	A12-50x40	50x40
Front lamps:		
clearance light	A12-5	5
turn indicators	A12-21-3	21
Rear lights:		
turn indicators	A12-21-3	21
clearance light	A-12-5	5
stop-light	A-12-21-3	21
Turn indicator repeaters**	A12-5	5
Backing lamp	A12-21-3	21
License plate lamp	A12-10	10
Special mark lamp	A12-10	10
Cab lamp	A12-10	10
Rear fog lamp	A12-21-3	21
Hand lamp	A12-21-3	21
Instrument illumination dome lamp	AMH12-3-1	3
Upper beam warning lamp	AMH12-3-1	3
Oil emergency pressure warning lamp	AMH12-3-1	3
Coolant emergency overheating warning lamp	AMH12-3-1	3
Turn indicator warning lamp	A12-1	1
Brake emergency condition warning lamp	A12-1	1
Parking brake warning lamp	A12-1	1
Emergency flasher warning lamp	A12-1.1	1.1

* On automobile YA3-3962

** Is not installed on automobile YA3-3303

TORQUES FOR MAIN THREADED CONNECTIONS, kgf · m

Stud nuts attaching cylinder block heads to cylinder block	9.0-9.4
Connecting rod bolt nuts	6.8-7.5
Crankshaft main bearing cap attachment nuts	12.5-13.6
Bolt nuts attaching flywheel to crankshaft	7.6-8.3
Bolt nuts attaching flanges to propeller shaft	3.2-4.0
Nuts attaching flange to axle pinion	16-22
Bolts attaching final drive gear to differential case	10-14
Spring U-bolt nuts	9.0-10
Wheel attaching nuts	10.5-12
Bolts attaching front axle driving flanges and rear axle axle shafts	6.0-7.0
Nut attaching steering arm to shaft	20-28
Steering rod ball pin nuts	6.0-8.0
Steering rod locknuts	10.5-13.0
Ball support attachment bolts	3.6-5.0
Wheel hub bearing locknuts	5.0-7.0
Anchor plate bolts:	
front	3.6-4.4
rear	4.4-5.6

Note. For other threaded connections, the torque should be equal to:

M6 - (0.45-1.0);

M8 - (1.4-1.8);

M10 - (3.0-3.5) kgf · m.

MAIN METERING JETS OF CARBURETTORS K-151B AND K-151E

Jets	1st chamber	2nd chamber
Main fuel jet	225±3 cm ³ /min (230±3 cm ³ /min)	330±4.5 cm ³ /min
Main air jet	330±4.5 cm ³ /min	230±3 cm ³ /min
Assembly of idling fuel jets:		
idling tube	95±1.5 cm ³ /min (110±1.5 cm ³ /min)	
emulsion tube	85±1.5 cm ³ /min	
Second idling air jet	330±4.5 cm ³ /min (175±2.5 cm ³ /min)	
Idling emulsion jet	280±3.5 cm ³ /min (175±2.5 cm ³ /min)	
Transfer fuel jet		150±2.0 cm ³ /min (200±2.5 cm ³ /min)
Transfer air jet		270±3.5 cm ³ /min

Notes. Some jets of the carburettors K-151B and K-151E differ in rated capacity. A value in brackets is indicated for the carburettor K-151E .

The data-sheet rated capacities indicated in the Table are indented on the corresponding jets.

CONTENTS

Important	3
Safety instructions	3
Precautions	3
Introduction	5
Automobile marking	6
Specifications	16
Controls and equipment of driver's and passenger's seats	24
Prestarting procedure	27
Automobile running-in	27
Starting and shutting down the engine	28
Starting the engine	28
Shutting down the engine	29
Features of driving under different road, meteorological and climatic service conditions	29
Maintenance of the automobile	32
Daily maintenance	33
Seasonal maintenance	33
Before the summer season of operation	33
Before the winter season of operation	34
Engine	34
Maintenance of the lubrication system	37
Maintenance of the crankcase ventilation system	39
Maintenance of the fuel system	39
Maintenance of the engine cooling system	44
Maintenance of the ignition system	47
Transmission	50
Maintenance of the clutch	50
Maintenance of the gearbox	51
Maintenance of the transfer box	53
Maintenance of the propeller shafts	54
Maintenance of the rear axle	54
Maintenance of the front axle	55
Chassis	57
Towing hook	57
Maintenance of the suspension	57
Wheels, tyres	58
Wheel hubs	61
Control systems	63
Maintenance of the steering gear	63
Brake systems	66
Maintenance of the service brakes	66
Maintenance of the parking brake	71
Electrical equipment	73
Maintenance of the alternator	73
Maintenance of the storage battery	73
Maintenance of the starter	74
Lighting system, light flashers and horn	75
Overload breakers	77
Instrumentation and warning flashers	77

Special tools and appliances	79
Body(cab)	81
Body (cab) ventilation	82
Body (cab) heating	82
Sanitary equipment of the automobile YA3-3962	83
Carrying patients	84
Fastening stretcher	85
Windshield wiper and windshield washer	86
Maintenance of the body	87
Lubrication of automobile	88
Preservation	89
Maintenance of automobile placed in storage	90
Depreservation	91
Lubricating materials and special fluids	92
Lubrication table	94
Transportation	99
Appendix 1	101
Lamps employed on automobiles	101
Appendix 2	
Torques for main threaded connections	102
Appendix 3	
Main metering jets of carburetors K-151B and K-151E	103
Appendix 4	
Wiring diagram of automobile YA3-3741	in Insert
Wiring diagram of automobiles YA3-3962, YA3-2206, YA3-3909	in Insert
Wiring diagram of automobile YA3-3303	in Insert
Wiring diagram of automobile YA3-39094	in Insert
Wiring diagram of automobile YA3-39095	in Insert
Wiring diagram of automobile YA3-33036	in Insert

FOR NOTES

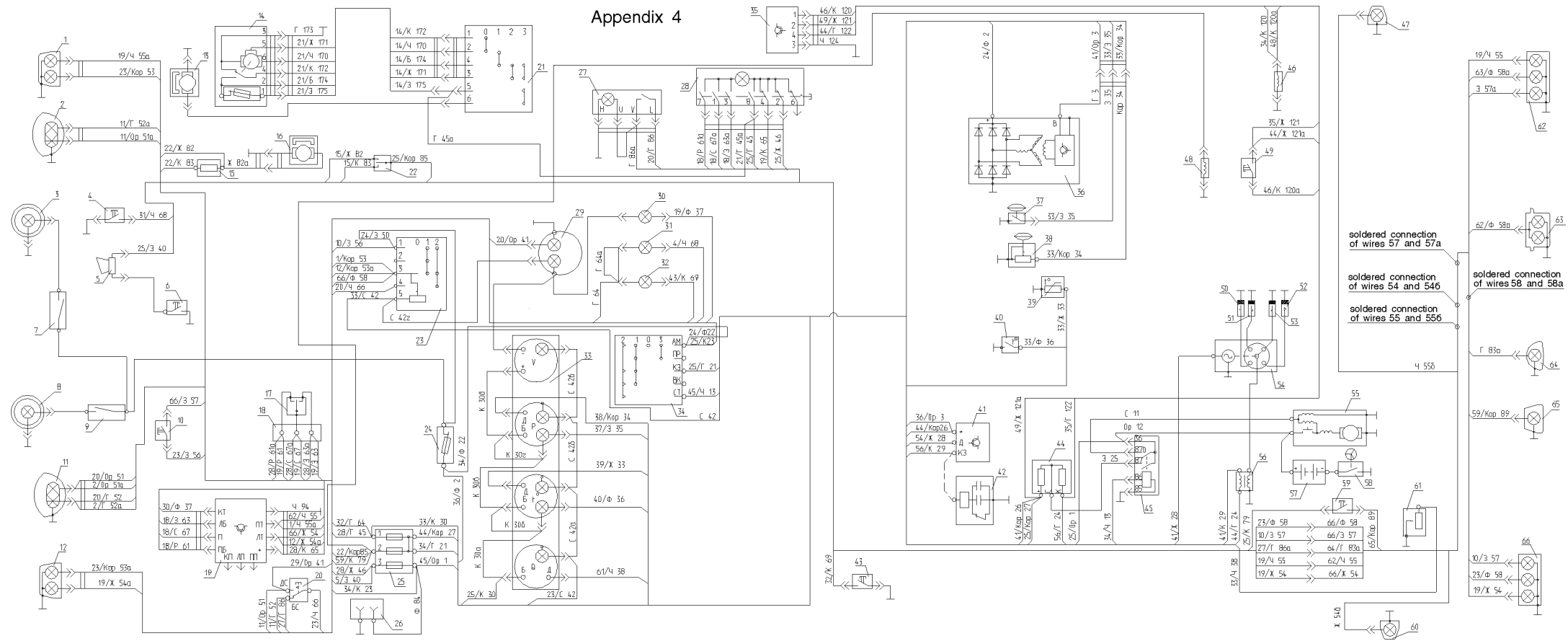

Fig. 1. Wiring Diagram of Automobile YA3-3741:

- 1 -front lamp; 2 -headlamp; 3, 8 -interior dome lamp; 4 -brake failure warning lamp switch; 5 -horn; 6 -horn button; 7, 9 -dome lamp switch; 10 -stop-light switch; 11 -headlamp; 12 -front lamp; 13 -windshield washer; 14 -windshield wiper; 15 -heater resistor; 16 -heater motor; 17 -turn indicator switch; 18 -connection panel; 19 -turn indicators and emergency warning lamp relay; 20 -headlamp switch; 21 -windshield wiper switch; 22 -heater switch; 23 -main light switch; 24 -thermal circuit breaker; 25 -fuse unit; 26 -receptacle; 27- emergency warning lamp switch; 28 -rear fog lamp switch; 29 -speedometer; 30 -turn indicator warning lamp; 31 -brake failure warning lamp; 32 -parking brake warning lamp; 33 -instrument panel; 34 -ignition switch; 35 -carburettor electronic control unit; 36 -alternator; 37 -oil emergency pressure transmitter; 38 -oil pressure transmitter; 39 -coolant temperature transmitter; 40 -coolant emergency temperature transmitter; 41 -transistor commutator; 42 -emergency vibrator; 43 -parking brake warning lamp switch; 44 -additional resistance; 45 -starter relay; 46 -carburettor electronic control solenoid valve; 47 -side repeater; 48 -carburettor solenoid valve; 49 -microswitch; 50-53 -spark plug; 54 -pickup-distributor; 55 -starter; 56 -ignition coil; 57 -storage battery; 58 -ground switch; 59 -backing lamp switch; 60 -side repeater; 61 -oil level transmitter; 62 -rear lamp; 63 -licence plate lamp; 64 -rear fog lamp; 65 -backing lamp; 66 -rear lamp

Wire Colour Code:

Б - white; Г - blue; Ж - yellow; 3 - green; К - red; Коп - brown; Оп - orange; С - grey; Ф - violet; Ч - black

Wire designation denotes: the first one or two numerals (before a slant line) denote the instrument number in the diagram to which this wire is connected; one or several letters (after a slant line) denote the wire colour; the last one or four signs denote the wire conventional number in the diagram

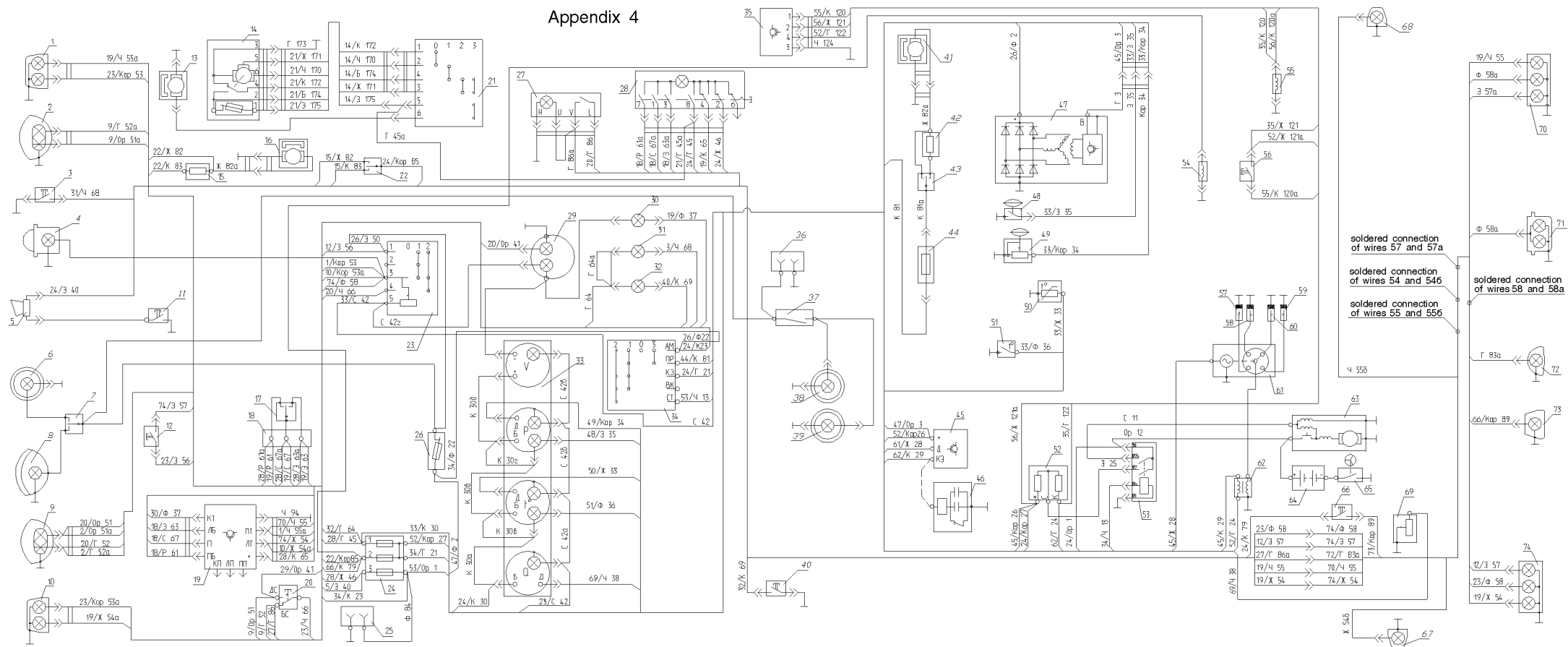

Fig. 2. Wiring Diagram of Automobiles YA3-3962, YA3-2206, YA3-3909:

- 1 -front lamp; 2 -headlamp; 3 -brake failure warning lamp switch; 4 -special mark lamp; 5 -horn; 6 -cab dome lamp; 7 -switch; 8 -swivelling headlamp; 9 -headlamp; 10 -front lamp; 11 -horn button; 12 -stop-light switch; 13 -windshield washer; 14 -windshield wiper; 15 -heater resistor; 16 -heater motor; 17 -turn indicator switch; 18 -connection panel; 19 -turn indicators and emergency warning lamp relay; 20 -headlamp switch; 21 -windshield wiper switch; 22 -heater switch; 23 -main light switch; 24 -fuse unit; 25 -receptacle; 26 -thermal circuit breaker; 27 -rear fog lamp switch; 28 -emergency warning lamp switch; 29 -speedometer; 30 -turn indicator warning lamp; 31 -brake failure warning lamp; 32 -parking brake warning lamp; 33 -instrument panel; 34 -ignition switch; 35 -carburettor electronic control unit; 36 -receptacle; 37 -dome lamp switch; 38, 39 -interior dome lamp; 40 -parking brake warning lamp switch; 41 -heater motor; 42 -heater resistor; 43 -heater switch; 44 -fuse; 45 -transistor commutator; 46 -emergency vibrator; 47 -alternator; 48 -oil emergency pressure transmitter; 49 -oil pressure transmitter; 50 -coolant temperature transmitter; 51 -coolant emergency temperature transmitter; 52 -auxiliary resistor; 53 -starter relay; 54 -carburettor solenoid valve; 55 -carburettor electronic control solenoid valve; 56 -microswitch; 57-60 -spark plug; 61 -pickup-distributor; 62 -ignition coil; 63- starter; 65 -storage battery; 66 -ground switch; 66 -backing lamp switch; 67, 68 -side repeater; 69 -fuel level transmitter; 70 -rear lamp; 71 -licence plate lamp; 72 -rear fog lamp; 73 -backing lamp; 74 -rear lamp

Positions 4 and 8 are not installed on the automobiles YA3-2206, YA3-3909

Wire Colour Code:

Б - white; Г- blue; Ж - yellow; 3 - green; К- red; Kop - brown; Op - orange; С - grey; Φ - violet; Ч - black

Wire designation denotes: the first one or two numerals (before a slant line) denote the instrument number in the diagram to which this wire is connected; one or several letters (after a slant line) denote the wire colour; the last one or four signs denote the wire conventional number in the diagram

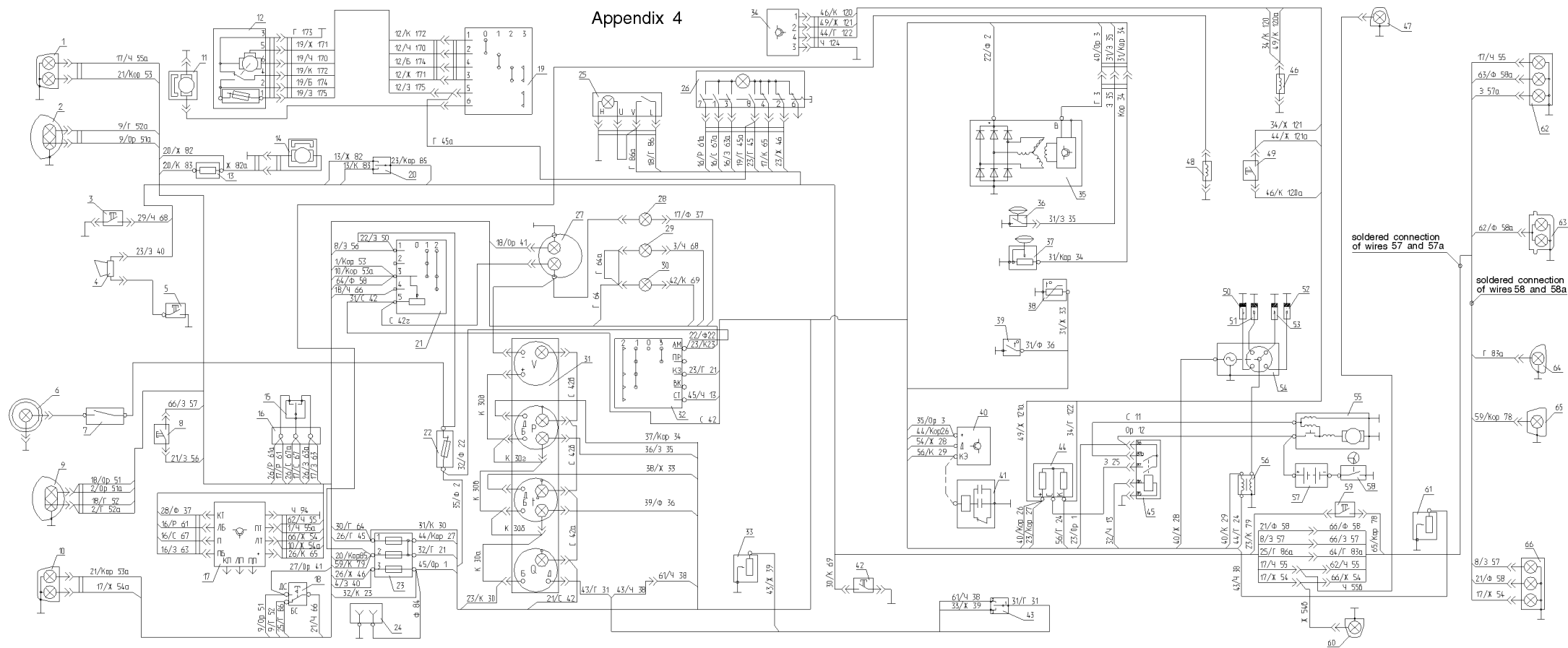

Fig. 3. Wiring Diagram of Automobile YA3-3303:

1 -front lamp; 2 -headlamp; 3 -brake failure warning lamp switch; 4 -horn; 5 -horn button; 6 -cab dome lamp; 7 -dome lamp switch; 8 -stop-light switch; 9 -headlamp; 10 -front lamp; 11 -windshield washer; 12 -windshield wiper; 13 -heater resistor; 14 -heater motor; 15 -turn indicator switch; 16 -connection panel; 17 -turn indicators and emergency warning lamp relay; 18 -headlamp switch; 19 -windshield wiper switch; 20 -heater switch; 21 -main light switch; 22 -thermal circuit breaker; 23 -fuse unit; 24 -receptacle; 25 -emergency warning lamp switch; 26 -rear fog lamp switch; 27 -speedometer; 28 -turn indicator warning lamp; 29 -brake failure warning lamp; 30 -parking brake warning lamp; 31 -instrument panel; 32 -ignition switch; 33 -fuel level transmitter; 34 -carburettor electronic control unit; 35 -alternator 665.3701 or 161.3771; 36 -oil emergency pressure transmitter; 37 -oil pressure transmitter; 38 -coolant temperature transmitter; 39 -coolant emergency temperature transmitter; 40 -transistor commutator; 41 -emergency vibrator; 42 -parking brake warning lamp switch; 43 -fuel level gauge switch; 44 -additional resistance; 45 -starter relay; 46 -carburettor electronic control solenoid valve; 47 -side repeater; 48 -carburettor solenoid valve; 49 -microswitch; 50-53 -spark plug; 54 -pickup-distributor; 55 -starter; 56 -ignition coil; 57 -storage battery; 58 -ground switch; 59 -backing lamp switch; 60 -side repeater; 61 -oil level transmitter; 62 -rear lamp; 63 -licence plate lamp; 64 -rear fog lamp; 65 -backing lamp; 66 -rear lamp

Wire Colour Code:

Б - white; Г - blue; Ж - yellow; 3 - green; К - red; Коп - brown; Оп - orange; С - grey; Ф - violet; Ч - black

Wire designation denotes: the first one or two numerals (before a slant line) denote the instrument number in the diagram to which this wire is connected; one or several letters (after a slant line) denote the wire colour; the last one or four signs denote the wire conventional number in the diagram

Appendix 4

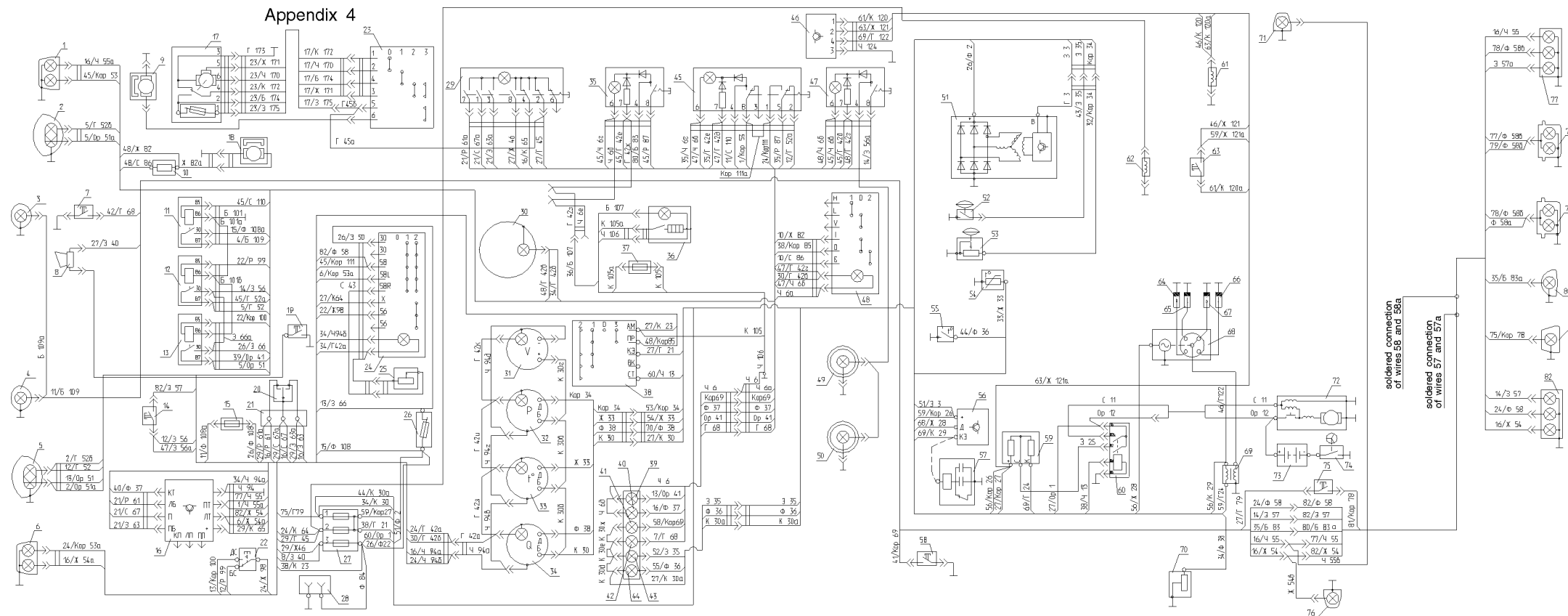

Fig. 4. Wiring Diagram of Automobile YA3-39094:

- 1 -front lamp; 2 -headlamp; 3,4 -fog lamp; 5 -headlamp; 6 -front lamp; 7 -brake failure warning lamp switch; 8 -horn; 9 -electric washer; 10 -heater resistor; 11 -fog lamp relay;
- 12, 13 -headlamp switch relay; 14 -stop-light switch; 15 -fog lamp switch; 16 -turn indicators and emergency warning lamp relay; 17 -windshield wiper; 18 -heater motor;
- 19 -horn button; 20 -turn indicator switch; 21 -connection panel; 22 -headlamp switch; 23 -windshield wiper switch; 24 -outer lighting switch; 25 -instrument lighting rheostat;
- 26 -thermal circuit breaker; 27 -fuse unit; 28 -receptacle; 29 -emergency warning lamp switch; 30 -speedometer; 31 -voltmeter; 32 -oil pressure gauge; 33 -coolant temperature gauge;
- 34 -fuel level gauge; 35 -rear fog lamp switch; 36 -cigarette lighter; 37 -cigarette lighter fuse; 38 -ignition switch; 39 -high beam warning lamp; 40 -turn indicator warning lamp;
- 41 -parking brake warning lamp; 42 -brake failure warning lamp; 43 -oil emergency pressure warning lamp; 44 -coolant emergency temperature warning lamp; 45 -fog lamp switch;
- 46 -carburettor electronic control unit; 47 -cab dome lamp switch; 48 -heater switch; 49 -cab dome lamp; 50 -interior dome lamp; 51 -alternator; 52 -oil emergency pressure transmitter;
- 53 -oil pressure transmitter; 54 -coolant temperature transmitter; 55 -coolant emergency temperature transmitter; 56 -transistor commutator; 57 -emergency vibrator; 58 -parking brake warning lamp switch;
- 59 -additional resistance; 60 -starter relay; 61 -carburettor electronic control solenoid valve; 62 -carburettor solenoid switch; 63 -microswitch; 64-67 -spark plug;
- 68 -pickup-distributor; 69 -ignition coil; 70 -fuel level transmitter; 71 -side repeater; 72 -starter; 73 -storage battery; 74 -ground switch; 75 -backing lamp switch;
- 76 -side repeater; 77 -rear lamp; 78, 79 -licence plate lamp; 80 -rear fog lamp; 81 -backing lamp; 82 -rear lamp

Wire Colour Code:

Б - white; Г - blue; Ж - yellow; 3 - green; К - red; Kop - brown; Op - orange; С - grey; Φ - violet; Ч - black

Wire designation denotes: the first one or two numerals (before a slant line) denote the instrument number in the diagram to which this wire is connected; one or several letters (after a slant line) denote the wire colour; the last one or four signs denote the wire conventional number in the diagram

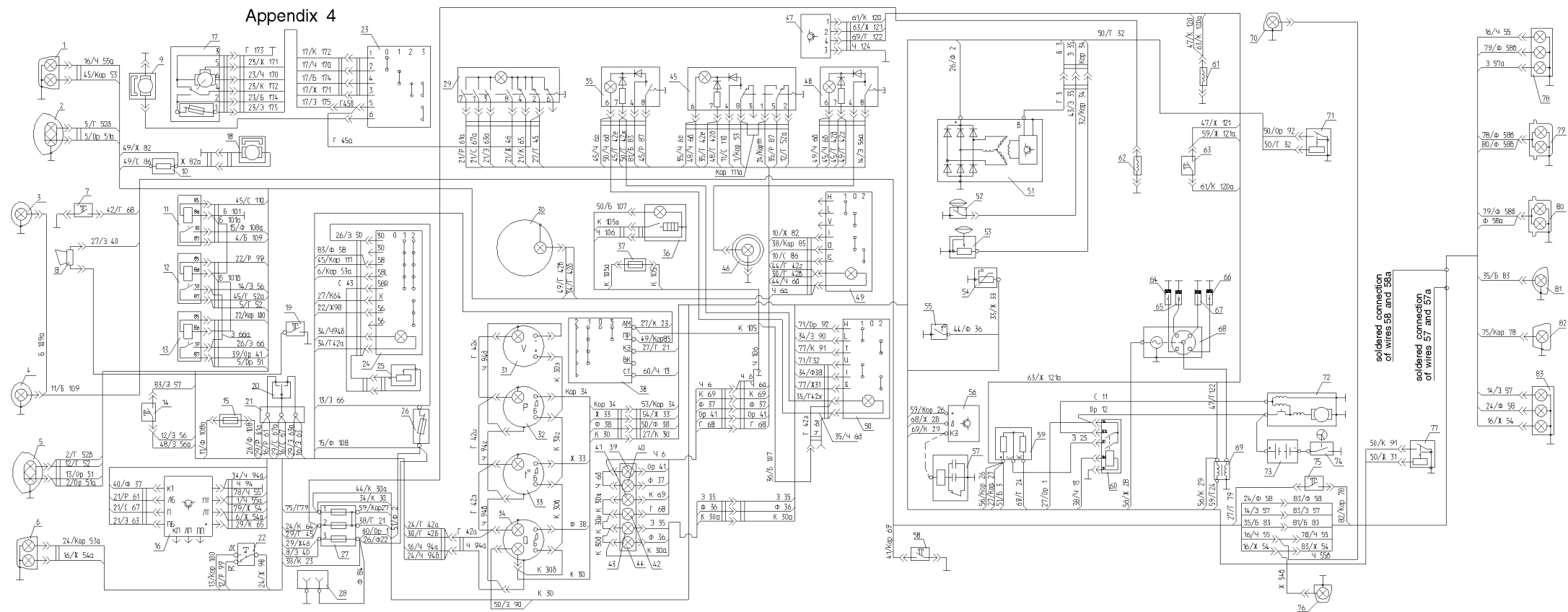

Fig. 5. Wiring Diagram of Automobile YA3-39095:

1 -front lamp; 2 -headlamp; 3,4 -fog lamp; 5 -headlamp; 6 -front lamp; 7 -brake failure warning lamp switch; 8 -horn; 9 -electric washer; 10 -heater resistor; 11 -fog lamp relay; 12, 13 -headlamp switch relay; 14 -stop-light switch; 15 -fog lamp fuse; 16 -turn indicators and emergency warning lamp relay; 17 -windshield wiper; 18 -heater motor; 19 -horn button; 20 -turn indicator switch; 21 -connection panel; 22 -headlamp switch; 23 -windshield wiper switch; 24 -outer lighting switch; 25 -instrument lighting rheostat; 26 -thermal circuit breaker; 27 -fuse unit; 28 -receptacle; 29 -emergency warning lamp switch; 30 -speedometer; 31 -voltmeter; 32 -oil pressure transmitter; 33 -coolant temperature transmitter; 34 -fuel level gauge; 35 -rear fog lamp switch; 36 -cigarette lighter; 37 -cigarette lighter fuse; 38 -ignition switch; 39 -high beam warning lamp; 40 -turn indicator warning lamp; 41 -parking brake warning lamp; 42 -brake failure warning lamp; 43 -oil emergency pressure warning lamp; 44 -coolant emergency temperature warning lamp; 45 -fog lamp switch; 46 -cab dome lamp; 47 -carburettor electronic control unit; 48 -interior dome lamp switch; 49 -heater switch; 50 -fuel level transmitter selector switch; 51 -alternator 665.3701 or 16.3771; 52 -oil emergency pressure transmitter; 53 -oil pressure transmitter; 54 -coolant temperature transmitter; 55 -coolant emergency temperature transmitter; 56 -transistor commutator; 57 -emergency vibrator; 58 -parking brake warning lamp switch; 59 -additional resistance; 60 -starter relay; 61 -carburettor electronic control solenoid valve; 62 -carburettor solenoid valve; 63 -microswitch; 64-67 -spark plug; 68 -pickup-distributor; 69 -ignition coil; 70 -side repeater; 71, 77 -fuel level transmitter; 72 -starter; 73 -storage battery; 74 -ground switch; 75 -backing lamp switch; 76 -side repeater; 78 -rear lamp; 79, 80 -licence plate lamp; 81 -rear fog lamp; 82 -backing lamp; 83 -rear lamp

Wire Colour Code:

Б - white; Г- blue; Ж - yellow; 3 - green; К- red; Kop - brown; Op - orange; С - grey; Φ - violet; Ч - black

Wire designation denotes: the first one or two numerals (before a slant line) denote the instrument number in the diagram to which this wire is connected; one or several letters (after a slant line) denote the wire colour; the last one or four signs denote the wire conventional number in the diagram

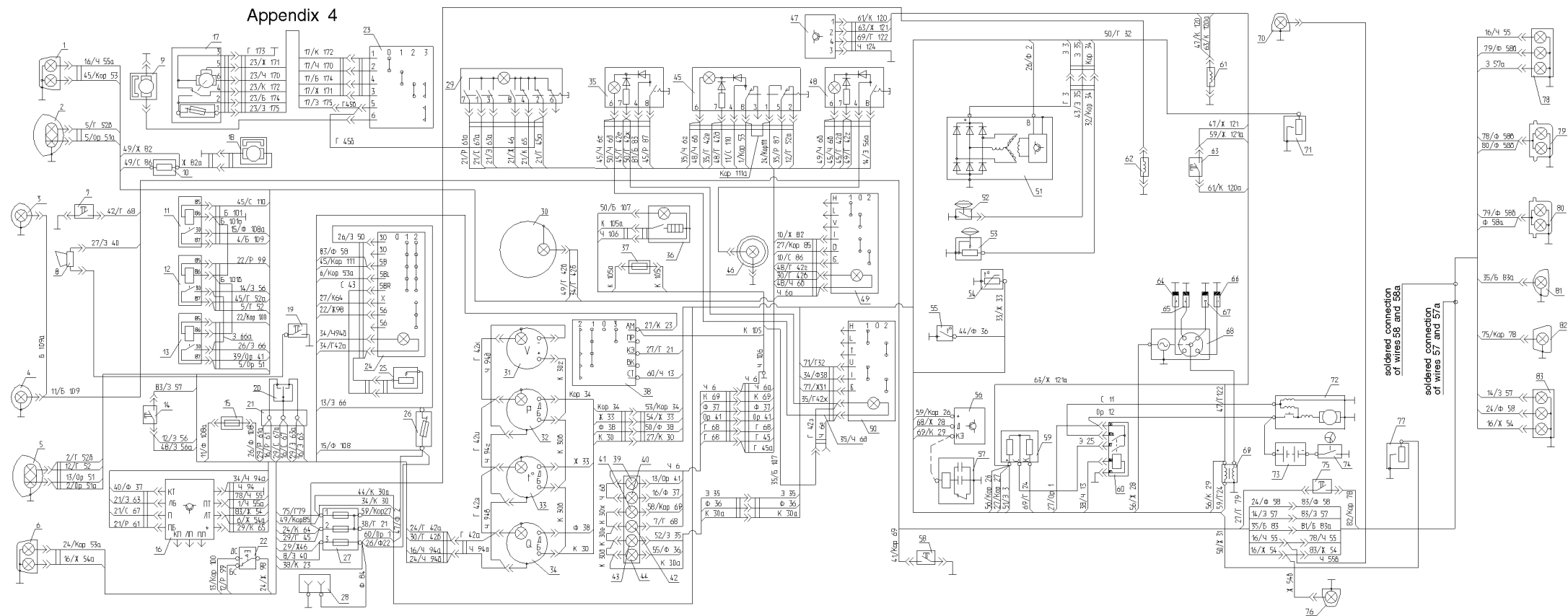

Fig. 6. Wiring Diagram of Automobile YA3-33036:

1 -front lamp; 2 -headlamp; 3,4 -fog lamp; 5 -headlamp; 6 -front lamp; 7 -brake failure warning lamp switch; 8 -horn; 9 -electric washer; 10 -heater resistor; 11 -fog lamp relay; 12, 13 -headlamp switch relay; 14 -stop-light switch; 15 -fog lamp fuse; 16 -turn indicators and emergency warning lamp relay; 17 -windshield wiper; 18 -heater motor; 19 -horn button; 20 -turn indicator switch; 21 -connection panel; 22 -headlamp switch; 23 -windshield wiper switch; 24 -outer lighting switch; 25 -instrument lighting rheostat; 26 -thermal circuit breaker; 27 -fuse unit; 28 -receptacle; 29 -emergency warning lamp switch; 30 -speedometer; 31 -voltmeter; 32 -oil pressure transmitter; 33 -coolant temperature transmitter; 34 -fuel level gauge; 35 -rear fog lamp switch; 36 -cigarette lighter; 37 -cigarette lighter fuse; 38 -ignition switch; 39 -high beam warning lamp; 40 -turn indicator warning lamp; 41 -parking brake warning lamp; 42 -brake failure warning lamp; 43 -oil emergency pressure warning lamp; 44 -coolant emergency temperature warning lamp; 45 -fog lamp switch; 46 -cab dome lamp; 47 -carburettor electronic control unit; 48 -interior dome lamp switch; 49 -heater switch; 50 -fuel level transmitter selector switch; 51 -alternator 665.3701-01; 52 -oil emergency pressure transmitter; 53 -oil pressure transmitter; 54 -coolant temperature transmitter; 55 -coolant emergency temperature transmitter; 56 -transistor commutator; 57 -emergency vibrator; 58 -parking brake warning lamp switch; 59 -additional resistance; 60 -starter relay; 61 -carburettor electronic control solenoid valve; 62 -disbalance valve solenoid valve; 63 -microswitch; 64-67 -spark plug; 68 -pickup-distributor; 69 -ignition coil; 70 -side repeater; 71, 77 -fuel level transmitter; 72 -starter; 73 -storage battery; 74 -ground switch; 75 -backing lamp switch; 76 -side repeater; 78 -rear lamp; 79, 80 -licence plate lamp; 81 -rear fog lamp; 82 -backing lamp; 83 -rear lamp

Wire Colour Code:

Б - white; Г- blue; Ж - yellow; 3 - green; К- red; Kop - brown; Op - orange; С - grey; Φ - violet; Ч - black

Wire designation denotes: the first one or two numerals (before a slant line) denote the instrument number in the diagram to which this wire is connected; one or several letters (after a slant line) denote the wire colour; the last one or four signs denote the wire conventional number in the diagram